

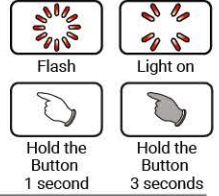

Thank you for purchasing our product. Before installing/operating the product, read the instructions carefully and retain them for future reference.

**⚠ Attention!**

- For installation, follow the steps described. Any damage caused by wrong installation shall be imputed to the users.
- To avoid a short circuit from occurring do not pull or modify the wires during installation.
- Do not disassemble or change any parts. Opening and disassembling this unit will void any warranty.
- Maintenance and repairs should be executed by our professionals only.



**Symbol description:**

**NOTE**

⚠ Some procedures must be followed to avoid damages to the product.

⚠ **WARNING!** Certain procedure must be followed to avoid damages to yourself, to the vehicle or to others.

**1-1 Accessories**

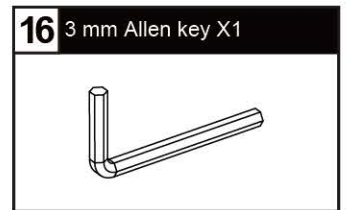
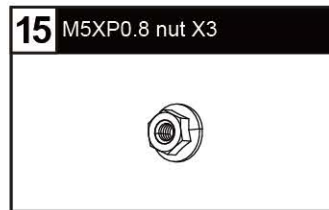
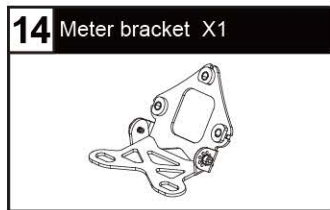
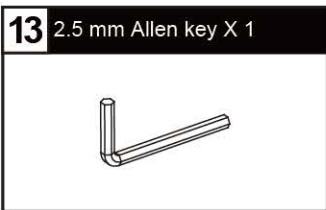
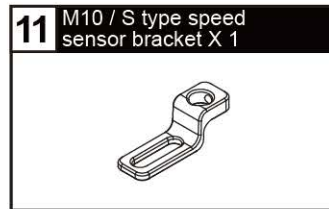
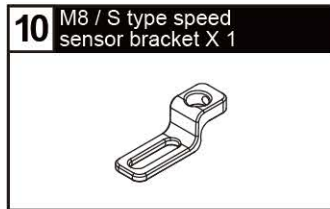
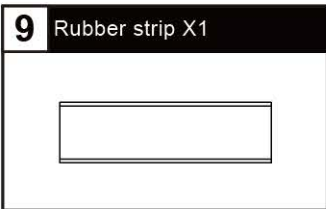
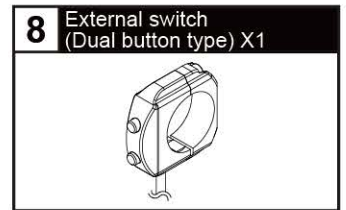
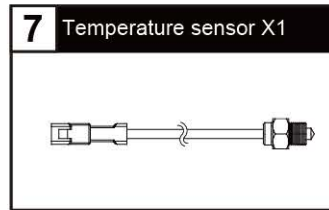
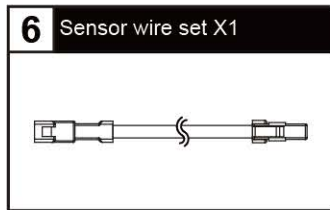
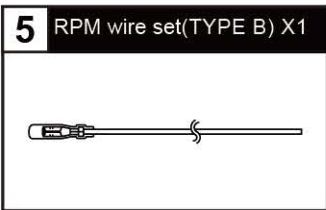
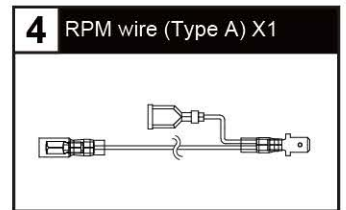
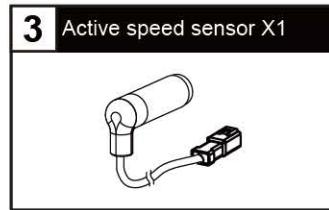
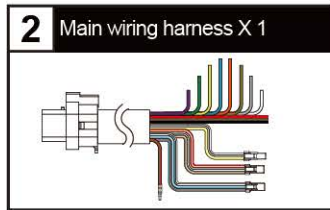
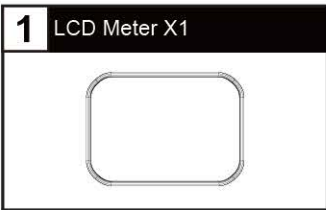

## 1-2 Optional accessories

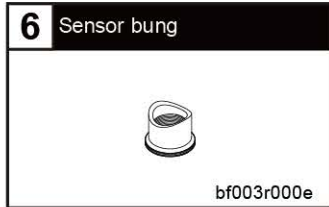
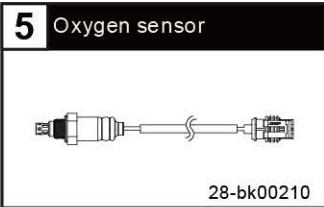
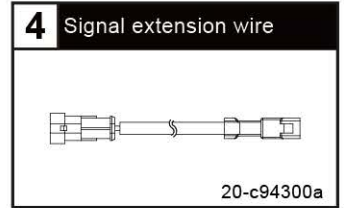
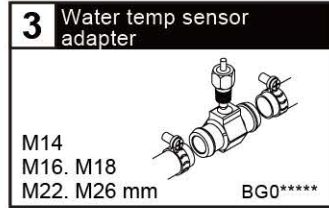
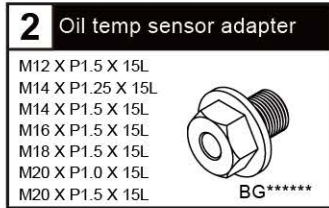
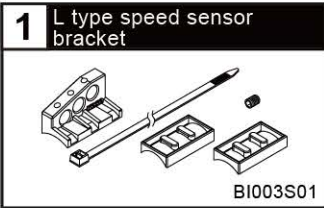

## 2-1 Wiring Installation Instructions

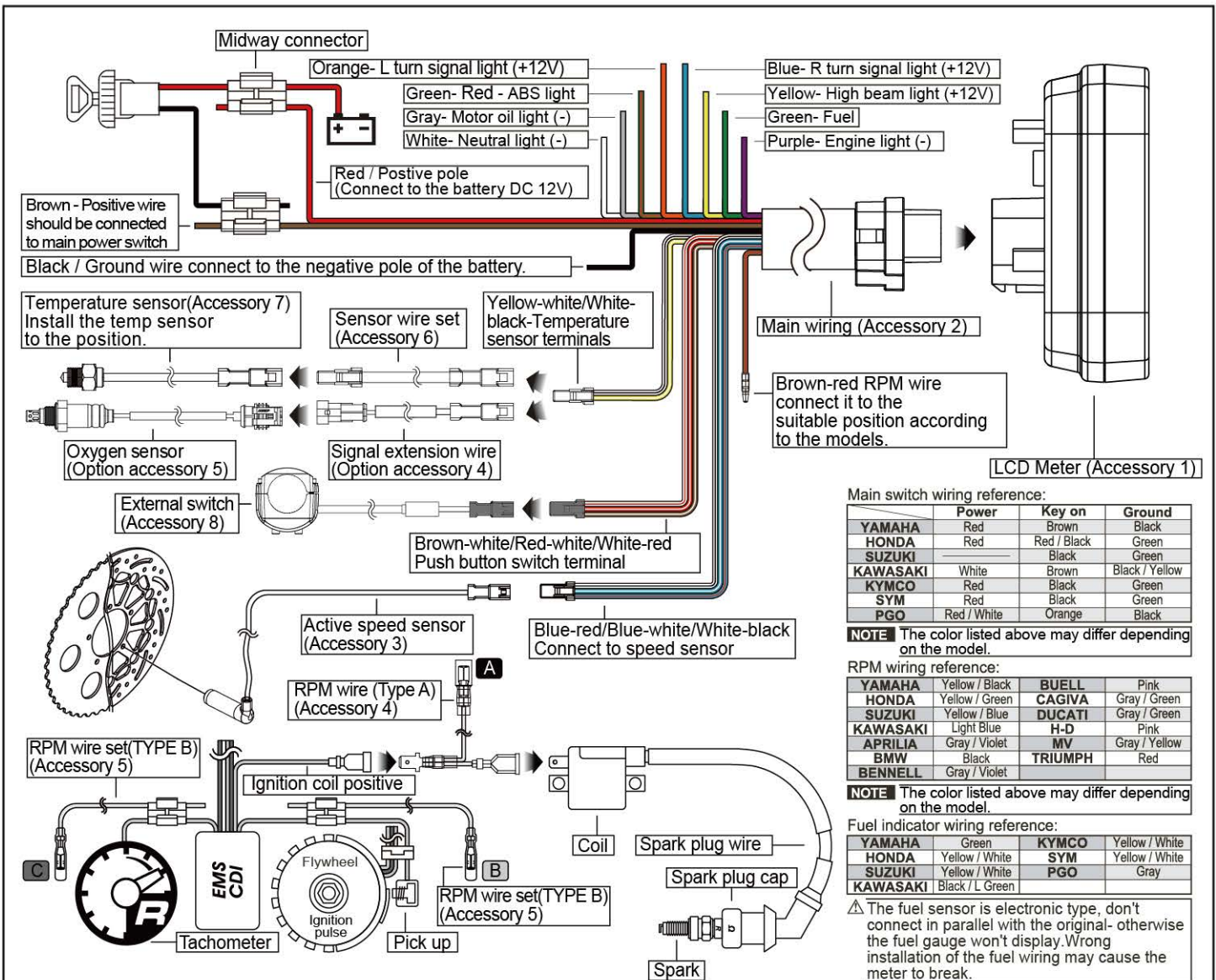

**NOTE** When connecting the power wire, carefully follow the instructions. If the red & brown wires are connected in parallel, the meter won't work properly.

### ⚠ RPM wire installation

We recommend installing the R-type spark plug and low-resistance spark plug cap at the same time.

A. Connect the RPM wire (Type A) on the spark plug wire by connecting the male and female connectors.

B. Connect the RPM wire (Type B) to the pick-up sensor.

C. Connect in parallel the RPM wire (Type A) with the original tachometer signal wire.

The best signal source will be in order as C>B>A. We suggest checking different ways if you have problems getting the RPM signal.

## 2-2 Installation instructions

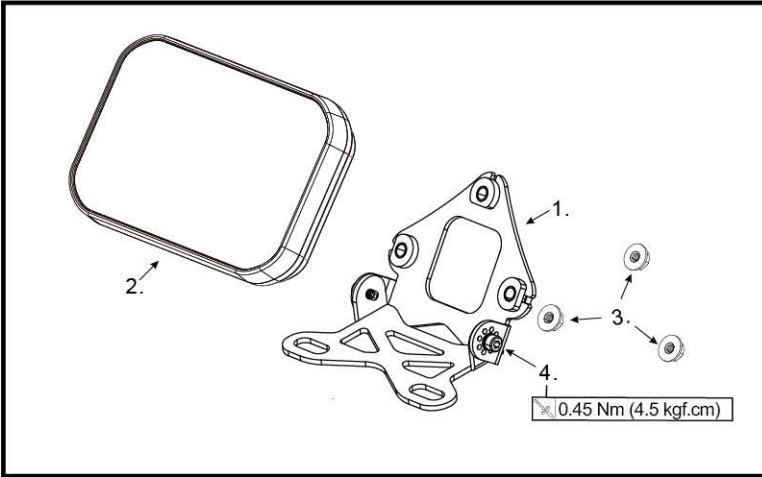

### Follow the steps below during installation.

1. Meter bracket (Accessory 14)
2. LCD Meter (Accessory1)
3. M5XP0.8 nut X3 (Accessory 15)
4. Meter bracket micro-adjustment screw

**NOTE** You can choose the angle first and then use the screw to fix the angle.

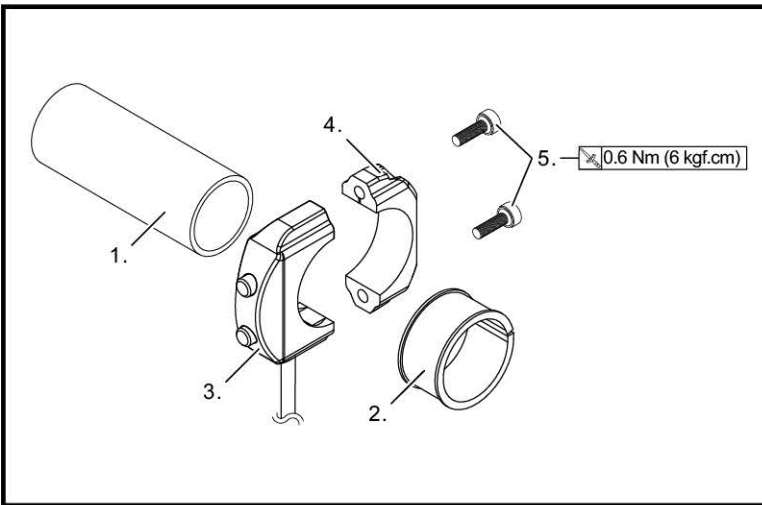

### Installation steps

1. Handle bar
2. Rubber strip (Accessory 9)

**CAUTION!** Refer to the list below and decide whether to use rubber strip according to the grip diameter.

Handle bar SIZE	Use Rubber strip
7/8"(22.2 mm)	NO
1"(25.4 mm)	YES

3. External switch (Dual button type) - Upper case (Accessory 8)
4. External switch (Dual button type) - Bottom case (Accessory 8)
5. M3x12xP0.5 mm screw (Accessory 8)

**CAUTION!** Total length of wiring is 600 mm. Pay attention to the distance between the wire exit hole and the end of handlebar to avoid insufficient wire length.

## 2-3 Oxygen Sensor Installation

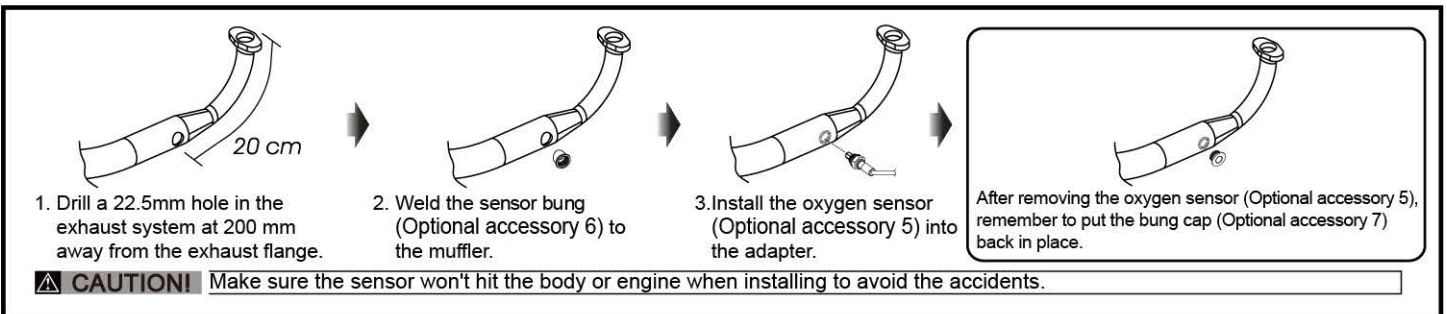

## MOTO / SCOOTER S-type speed sensor bracket instruction



Install the s-type sensor bracket.

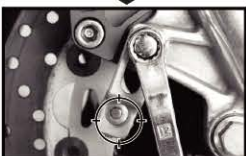

Adjust the sensor bracket position to make sure that the sensor faces the magnet to prevent bad speed signal or no signal.



Install the speed sensor on the bracket.



Adjust the distance between sensor and magnet. We suggest you make sure the distance is under 1 mm for an optimal speed signal.

# MOTO / SCOOTER L-type speed sensor bracket instruction



Install the L-bracket and the anti-slip rubber on the front fork and adjust it to the proper height and angle.



Install the speed sensor into the proper hole on the bracket.



Use the zip tie to fix the bracket on the front fork. Make sure the disc screw can pass the hole on the bracket for you to install the sensor into the same hole for catching the speed signal.



Adjust the distance between the sensor and screw to get the best speed signal. Make sure the distance is under 2mm to get the best signal.

**P.S.**



The active speed sensor could be facing the metal parts to detect the speed.

EX. 1 The disc screw.

EX. 2 The disc to detect the disc gap (make sure the distances between the gaps are the same in advance to avoid wrong speed signal.)

EX. 3 The sprocket to detect the disc gap (make sure the distances between the gaps are the same in advance to avoid wrong speed signal).

EX. 4 Rear disc - detect the gap between the disc.

**We suggest you to catch the speed from the disc screws. The more the sensor points are, the better the speed accuracy is. The maximum sensor points the speed sensor could detect is 40 points per turn.**

**⚠ After installation, use your hand to turn the tire to see if everything is ok. The LED on the active speed sensor will light up once the signal is detected.**

EX. 1

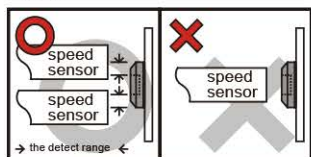

**The hexagon socket disc screw**  
The best detect area: The edge of the hexagon socket screw.

⚠ Don't pick-up the signal from the middle hole of the hexagon socket screw to avoid wrong signal.

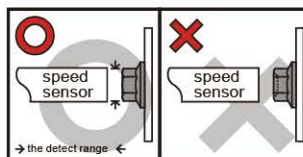

**The hexagon screw**  
The best detect area: The middle of the screws.

⚠ Some hexagon screws have a small hole in the center. In this case, we suggest you catch the signal from the edge of the screw like the hexagon socket screw.

EX. 2,4

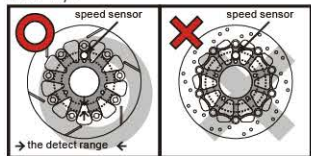

**The disc**  
The best detection area: Detect the speed signal from the gaps of the disc.

⚠ Note that there are discs with the gaps in different difference, and this method will not work on it.

EX. 3

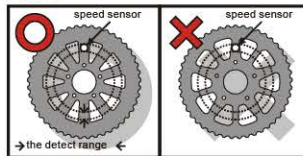

**The sprocket**  
The best detect area: Detect the speed signal from the gaps of the sprocket.

⚠ Note that there are sprockets with the gaps in different places, and this method will not work on it.

## 3-1 Meter Size

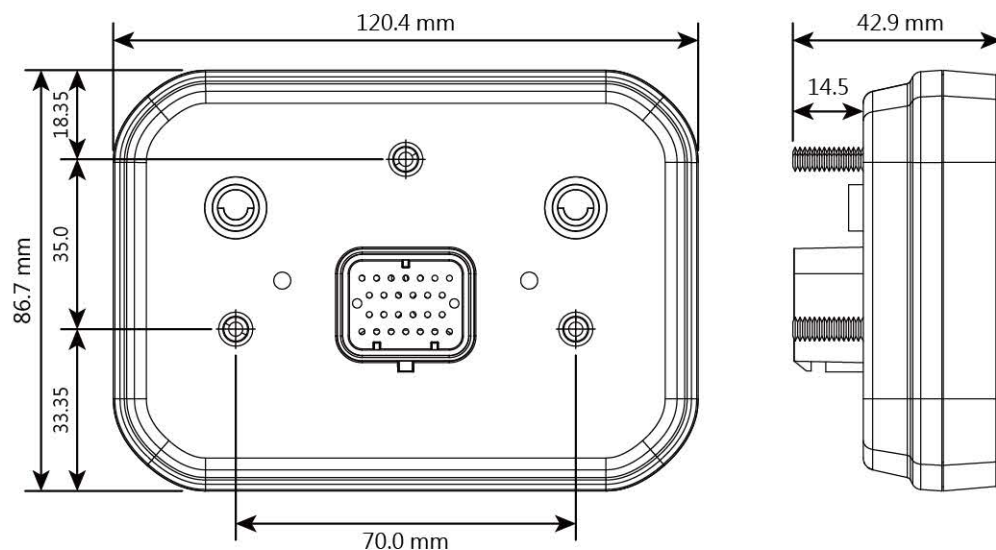

## 3-2 Basic Function Instructions

### Shift light warning

- Setting range : 1,000~10,000 RPM/ 1,000~12,000 RPM/ 1,000~15,000 RPM/ 1,000~18,000 RPM/ 1,000~20,000 RPM
- Setting unit : 100 RPM

### Fuel warning

- Setting range : 0 ~ 3/6
- Setting unit : 1

### Overheat warning

- Setting range : 60 ~ 250 °C (140 ~ 482 °F)
- Setting unit : 1 °C (°F)

### Low voltage warning

- Setting range : DC 8.0~13.0 V
- Setting unit : DC 0.1 V

### High voltage warning

- Setting range : DC 13.1~18.0 V
- Setting unit : DC 0.1 V

### Speeding warning

- Setting range : 30~360 km/h (20~225 MPH)
- Setting unit : 1 km/h (MPH)

### Motor oil maintenance

- Setting range : 500 ~ 16,000 km(300~10,000 mile),OFF
- Setting unit : 100 km(mile)

### Tachometer

- Display range : 0~10,000 RPM/ 0~12,000 RPM/ 0~15,000 RPM/ 0~18,000 RPM/ 0~20,000 RPM

### Indicator

- Composite warning light (Red) 
- Left indication light (Green) 
- Motor oil light (Red) 
- ABS light (Amber) 
- Theft light (Red) 
- Right indication light (Green) 
- High beam light (Blue) 
- Neutral light (Green) 
- Engine light (Amber) 

### Odometer

- Display range : 0 ~ 999,999 km (mile) and then return to zero
- Display unit : 1 km (mile)

### Trip meter A, B

- Display range : 0~9,999.9 km (mile), may return to zero manually
- Display unit : 0.1 km (mile)

### Motor oil maintenance

- Display range : 500 ~ 16,000 km(300~10,000 mile),OFF
- Display unit : 1 km (mile)



### Light sensing

### Gear Meter

- Display range : -, N, 1~the highest gear, (the highest gear shall be based on the gear learning)

### Speedometer

- Display range : 0 ~ 360 km/h (0 ~ 225 MPH)
- Display unit : 1 km/h (MPH) Switchable

### Clock

- Setting range : 00:00~23:59 (24H)  
01:00~12:59 (12H)

### Thermometer

- Display range : 0 ~ 250.0 °C (32.0 ~ 482.0 °F)
- Display unit : 0.1 °C (°F)

### A/F ratio meter

- Display range : 12.1~17.5
- Display unit : 0.1











### Voltmeter

- Display range : DC 8.0 ~ 18.0 V
- Display unit : DC 0.1 V

### Fuel meter

- Display range : 6 levels(0 ~ 100%)
- Display unit : 1 level(16.6 %)

### 3-2 Specifications(Meter)

●Speedometer	Display range : 0 ~ 360 km/h (0 ~ 225 MPH) Display unit : 1 km/h (MPH) Switchable	●Clock	Setting range : 00:00~23:59 (24H) 01:00~12:59 (12H)
○Odometer	Display range : 0 ~ 999,999 km (mile)and then return to zero Display unit : 1 km (mile)	●Voltmeter	Display range : DC 8.0 ~ 18.0 V Display unit : DC 0.1 V
○Trip meter A, B	Display range : 0~9,999.9 km (mile), may return to zero manually Display unit : 0.1 km (mile)	○Low voltage warning	Setting range : DC 8.0~13.0 V, when setting value is reached or below, warning light will light up. Setting unit : DC 0.1 V
○Motor oil maintenance	Setting range : 500 ~ 16,000 km(300~10,000 mile),OFF Setting unit : 100 km(mile)	○High voltage warning	Setting range : DC 13.1~18.0 V, when setting value is reached or above, warning light will light up. Setting unit : DC 0.1 V
○Speeding warning	Setting range : 30~360 km/h (20~225 MPH) Setting unit : 1 km/h (MPH)	●Target speed	Setting range : 30 ~ 360 km/h (20 ~ 225 MPH) Setting unit : 5 km/h (MPH)
○Max. speed record	Display range : 0 ~ 360 km/h (0 ~ 225 MPH) Display unit : 1 km/h (MPH)	●Target distance	Setting range : 50 ~ 1,500 m (1/32 ~ 30/32 mile) Setting unit : 50 m (1/32 mile)
○Circumference	Setting range : 300~2,500 mm Setting unit : 1 mm	●Top speed	Display range Speed : 0 ~ 360 km/h (0 ~ 225 MPH) Distance : 0 ~ 999 m (0~3,280 feet) Rotating speed : 0~10,000 RPM/ 0~12,000 RPM/ 0~15,000 RPM/ 0~18,000 RPM/ 0~20,000 RPM Time : 0 ~ 9 : 59"99
○Sensitive point	Setting range : 1~40 P Setting unit : 1 P	●Sort by	Setting range : Sequence, Best
●Gear Meter(Learning)	Display range : -, N, 1~the highest gear, (the highest gear shall be based on the gear learning)	●Background display	Setting range : Auto(automatically switch according to the light : day mode display for the bright environment and Night mode display for the dark environment), Day mode, Night mode.
○Max. Gear record	Display range : -, N, 1~the highest gear (the highest gear shall be based on the gear learning)	○Back light brightness (Day)	Setting range : 3/5~ 5/5(Brightest) Setting unit : 1/5
●Tachometer	Display range : 0~10,000 RPM/ 0~12,000 RPM/ 0~15,000 RPM/ 0~18,000 RPM/ 0~20,000 RPM	○Back light brightness (Night)	Setting range : 1/5(Darkest) ~ 5/5(Brightest) Setting unit : 1/5
○Shift light warning	Setting range : 1,000~10,000 RPM/ 1,000~12,000 RPM/ 1,000~15,000 RPM/ 1,000~18,000 RPM/ 1,000~20,000 RPM Setting unit : 100 RPM	○Backlight color	Setting range : white, orange, yellow, green, blue, Loop switch
○Max. rotating speed	Display range : 0~10,000 RPM/ 0~12,000 RPM/ 0~15,000 RPM/ 0~18,000 RPM/ 0~20,000 RPM	●Unit	Speed unit : km/h , MPH Temperature unit : °C (Celsius) and °F (Fahrenheit)
○The RPM input signal number setting	Setting range : 0.5, 1.0~24.0	●Voltage	DC 12 V
○The RPM input pulse	Setting range : Low-Act, High-Act	●Operating temperature	-20~ 85 °C
●Thermometer	Display range : 0 ~ 250.0 °C (32.0 ~ 482.0 °F) Display unit : 0.1 °C (°F)	○Storage temperature	-30~ 90 °C
○Overheat warning	Setting range : 60 ~ 250 °C (140 ~ 482 °F), when setting value is reach or above, warning light will lit. Setting unit : 1 °C (°F)	●Specification	JIS D 0203 (S2)
○Max. temperature record	Display range : 0 ~ 250 °C (32.0 ~ 482 °F)	●Meter Size	120.4 x 86.7 x 45.3 mm
●A/F ratio meter	Display range : 12.1~17.5 Display unit : 0.1 Setting range : ON, OFF	●Meter Weight	± 206 g
●Fuel meter	Display range : 6 levels(0 ~ 100%) Display unit : 1 level(16.6 %) Setting range : 100 Ω, 250 Ω, 270 Ω,390 Ω, 510 Ω, 1200 Ω, Switch, Custom,OFF	●Indicator	Composite warning light (Red)  Left indication light (Green)  Motor oil light (Red)  ABS light (Amber)  Theft light (Red)  Right indication light (Green)  High beam light (Blue)  Neutral light (Green)  Engine light (Amber) 
○Fuel warning	Setting range : 0 ~ 3/6, when setting value is reach or below, warning light will lit. Setting unit : 1	○Light sensing	

**NOTE** Design and specifications are subject to change without notice.

### 3-3 Size & Specifications (Meter External Switch)

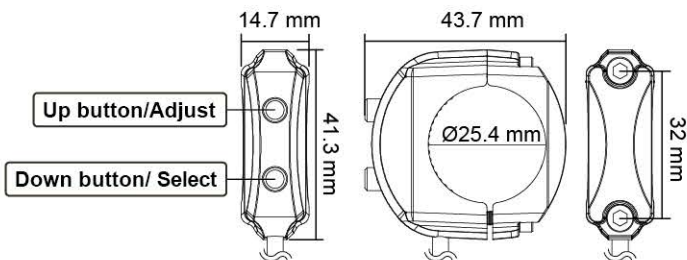

●Operating temperature	-20~ 85 °C
○Storage temperature	-30~ 90 °C
●Standard	JIS D 0203
●Effective voltage	DC 8 ~ 32V / Max. 50 mA / 1.6W
●Size	About 43.7 x 41.3 x 14.7 mm
●Weight	About 39 g

**NOTE** Meter external switch (Accessory 8) is suitable for 22.2 mm (7/8") & 25.4 mm (1") handlebar.

**NOTE** Design and specifications are subject to change without notice.

## 4 Startup Screen Switching Description



- In the main screen, press the **Up+Down** buttons to enter the record screen.



- In the checking screen, press the **Up+Down** buttons to go back to the main screen.

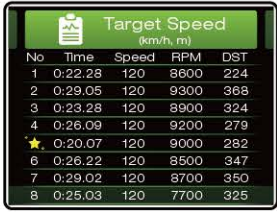

- In the record screen, press the **Up+Down** buttons to enter the checking screen.



- In the main screen.



## 4-1 Main Menu Switching Description



- In the ODO screen, press the **Down** button to enter the Trip A screen.



- In the Max. record screen, press the **Down** button to go back to the ODO screen.



- Press the **Down** button for 3 seconds to reset Max. records.



- In the Trip A screen, press the **Down** button to enter the Trip B screen.
- Press the **Down** button for 3 seconds to clear the Trip A recordings.



TRIP A 9999.9 km → TRIP A 0.0 km



- In the ODO screen.



- In the Trip B screen, press the **Down** button to enter the motor oil maintenance screen.
- Press the **Down** button for 3 seconds to clear the Trip B recordings.



TRIP B 9999.9 km → TRIP B 0.0 km

- Regardless of the main screen, press the **Up** button for 3 seconds to enter the fast setting for Clock and Backlight.



- In the motor oil maintenance screen, press the **Down** button to enter the Max. record screen.
- Press the **Down** button for 8 seconds, to reset motor oil maintenance screen.



TRIP O -999 km → TRIP O 500 km

## 4-2 Record Screen Switching Description(Target Speed, Target Distance, Top Speed)



- In the main screen, press the **Up+Down** buttons to enter the target speed record screen.



- In the top speed record screen, press the **Up+Down** button to enter the checking screen.



- In the target speed record screen, press the **Up** button to enter the target distance record screen.



- In the checking screen.



- In the target distance record screen, press the **Up** button to enter the top speed record screen.

- Regardless of the record screen, press the **Up** button for 3 seconds to enter the Power Test fast setting.



### 4-2-1 Description Of Target Speed Test



- In the target speed record screen, press the **Down** button to enter the testing screen.

**NOTE** Start the test when the bike is fully stopped.



- When you reach the target speed that you set (0~120 km/h), the timer will stop (25"03 second).

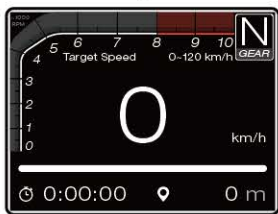

- In the testing screen.
- ⚠ WARNING!** Use this function on racetracks to avoid accidents.

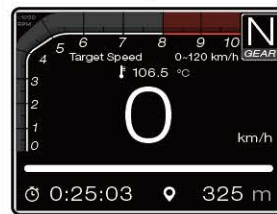

- When speed decreases to 0 km/h (MPH), the target speed record screen will appear.



- When the bike moves, the timer will start automatically.

**NOTE** The timer is automatic, so when your bike starts to move the timer will start to calculate the time and stop automatically when you stop the bike.



- In the target speed record screen.
- Press the **Down** button for 3 seconds, to reset the target speed record.



- Speed up.

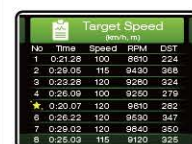

- Press the **Up** button to cancel deletion.
- Press the **Down** button to confirm deletion.

- Deletion succeeded.

## 4-2-2 Description Of Target Distance Test

No	Time	Speed	RPM	DST
1	0:21.28	74	9610	300
2	0:29.05	86	9430	500
3	0:23.28	92	9280	500
4	0:26.09	72	9250	350
★	0:19.17	76	8060	300
6	0:26.22	103	9530	650
7	0:29.02	54	6320	350
8	0:25.03	88	5220	500

●In the target distance record screen, press the **Down** button to enter the testing screen.

**NOTE** Start the test when the bike is fully stopped.



●When you reach the target distance that you set (100 M . 2/32 mile), the timer will stop (12"27 second).

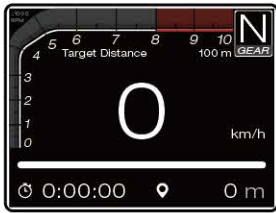

●In the testing screen.

**WARNING!** Use this function on racetracks to avoid accidents.

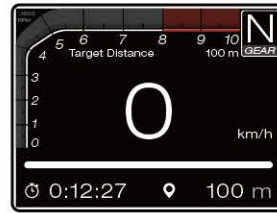

●When speed decreases to 0 km/h (MPH), the target distance record screen will appear.



●When the bike moves, the timer will start automatically.

**NOTE** The product adopts digital sensing; when the vehicle starts, the timer will immediately start measuring. Upon achieving the target distance, the timer will immediately stop measuring.

No	Time	Speed	RPM	DST
1	0:21.28	74	9610	300
2	0:29.05	86	9430	500
3	0:23.28	92	9280	500
4	0:26.09	72	9250	350
★	0:19.17	76	8060	300
6	0:26.22	103	9530	650
7	0:29.02	54	6320	350
8	0:25.03	88	5220	500

●In the target distance record screen.

●Press the **Down** button for **3 seconds**, to reset the target distance record.



●Speed up.

No	Time	Speed	RPM	DST
1	0:21.28	74	9610	300
2	0:29.05	86	9430	500
3	0:23.28	92	9280	500
4	0:26.09	72	9250	350
★	0:19.17	76	8060	300
6	0:26.22	103	9530	650
7	0:29.02	54	6320	350
8	0:25.03	88	5220	500



●Press the **Up** button to cancel deletion.  
●Press the **Down** button to confirm deletion.

●Deletion succeeded.

## 4-2-3 Description Of Top Speed Test

No	Time	Speed	RPM	DST
1	0:10.28	74	8610	53
★	0:10.05	86	9430	61
3	0:20.28	92	9280	103
4	0:25.09	102	9250	355
5	0:19.17	72	8060	299
6	0:26.22	103	9530	387
7	0:29.02	54	6320	204
8	0:25.03	88	9220	520

●In the top speed record screen, press the **Down** button to enter the testing screen.

**NOTE** Start the test when the bike is fully stopped.

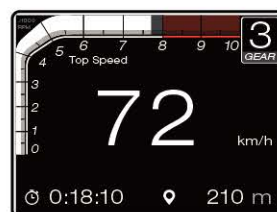

●Speed up.

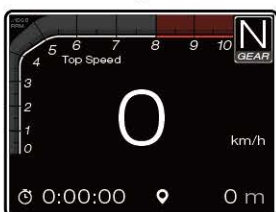

●In the testing screen.

**WARNING!** Use this function on racetracks to avoid accidents.



●When you reach the top speed (100 km/h), the meter will stop counting the distance (510 m), and time (25"65 seconds).

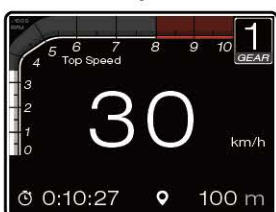

●When the bike moves, the timer will start automatically.

**NOTE** Display range(Top speed) :  
Speed : 0 ~ 360 km/h (0 ~ 225 MPH)  
Distance : 0 ~ 999 m (0~3,280 feet)  
Rotating speed : 0~10,000 RPM/  
0~12,000 RPM/ 15,000 RPM/  
0~18,000 RPM/ 0~20,000 RPM  
Time : 0 ~ 9'59"99

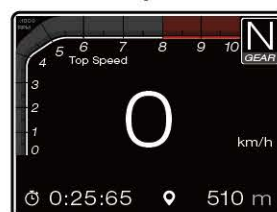

●When speed decreases to 0 km/h(MPH), the top speed record screen will appear.

**NOTE** The product adopts digital sensing; when the vehicle starts, the odometer and the timer will immediately start measuring. Upon achieving the maximum speed, the odometer and the timer will immediately stop measuring.

**WARNING!** The speed unit of the function will change according to 5-2 Change in Speed Unit.

Top Speed (km/h, m)				
No	Time	Speed	RPM	DST
1	0:10.28	74	8610	53
★	0:10.05	86	9430	61
3	0:20.28	92	9280	103
4	0:25.09	102	9250	355
5	0:19.17	72	8060	299
6	0:26.22	103	9530	387
7	0:29.02	54	6320	204
8	0:25.03	88	9220	520



- In the top speed record screen.
- Press the **Down** button for **3 seconds**, to reset the top speed record.

Top Speed (km/h, m)				
No	Time	Speed	RPM	DST
1	0:10.28	74	8610	53
★	0:10.05	86	9430	61
3	0:20.28	92	9280	103
4	0:25.09	102	9250	355
5	0:19.17	72	8060	299
6	0:26.22	103	9530	387
7	0:29.02	54	6320	204
8	0:25.03	88	9220	520



Top Speed (km/h, m)				
No	Time	Speed	RPM	DST
1	0:10.28	74	8610	53
2	Delete Records?			
3	Abort Delete			
4	Delete			
5	Delete			
6	Delete			
7	0:29.02	54	6320	204
8	0:25.03	88	9220	520



Top Speed (km/h, m)				
No	Time	Speed	RPM	DST
Success!				

- Press the **Up** button to cancel deletion.
- Press the **Down** button to confirm deletion.
- Deletion succeeded.

### 4-3 Checking Screen Switching Description



- In the main screen, press the **Up+Down** buttons for **2 times** to enter the checking screen.



- In the main screen.



- In the checking screen, press the **Up+Down** buttons to go back to the main screen.
- Press the **Down** button for **3 seconds** to clear all MAX. record.



## 5 Setting Screen Switching Description

- Press the **Up + Down** buttons for 3 seconds on the main screen, record screen, or checking screen to switch to the setting screen.
- Press the **Up** button or **Down** button to select
- ① Clock ② Unit (Speed & Temp.) ③ Backlight (Mode & Brightness & Color) ④ Overspeed Warning ⑤ Shift Light Warning
- ⑥ Temp Warning ⑦ Volt Warning ⑧ Low Fuel Warning ⑨ Motor Oil Maintenance (Trip O) ⑩ ABS Warning ⑪ Warning Light
- ⑫ Tire Circumference & Sensing Point ⑬ Gear ⑭ RPM (Pulse & signal & Range) ⑮ Fuel resistance
- ⑯ A/F Ratio ⑰ Power Test ⑱ Internal and External ODO ⑲ Meter information.
- Press the **Down** button for 3 seconds to enter the setting function screen.
- In the setting screen, press the **Up** button for 3 seconds to switch to the startup screen.

**NOTE** During setting, if button is not pressed in 3 minutes, it will automatically return to the startup screen.



## 5-1 Clock Settings



- In the Clock screen, press the **Down** button for 3 seconds to enter the clock setting.



- **Example : Changing the 12H.**
- Press the **Up** button to choose the setting number.
- ⚠ **Now the setting value is flashing.**
- NOTE** Setting range : 12 H, 24 H.  
Default value : 24 H.



- EX : Set time format from 24 H to 12 H.
- Press the **Down** button to enter time adjustment hour setting.



- **Example : To set clock(hour) as 10 hours.**
- Press the **Up** button to choose the setting number.
- ⚠ **Now the setting value is flashing.**
- NOTE** Cursor moving order is :  
Hour → Digit in ten minutes →  
Digit in minutes
- NOTE** Setting range : 1~12(12H)  
0 ~23(24H)  
Default value : 12(12H)/0(24H)



- EX : Set hour from 12:00 AM to 10:00 PM.
- Press the **Down** button to enter clock adjustment minute setting.



- **Example : To set clock(minute) as 10 minutes.**
- Press the **Down** button to move to the digit you want to set.
- ⚠ **Now the setting value is flashing.**
- NOTE** Setting range : 00~59 minutes.  
Default value : 0.



- Press the **Up** button to choose the setting number.



- EX : Set minute from 0 minute to 10 minutes.
- Press the **Down** button to go back to the clock screen.



- The Clock screen.

## 5-2 Unit (Speed & Temp.) Settings

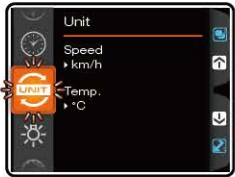

- In the unit screen, press the **Down** button for 3 seconds to enter the speed unit setting.



- **Example : To set speed unit as MPH.**
- Press the **Up** button to choose the setting options.
- ⚠ **Now the setting value is flashing.**
- NOTE** Setting range : km/h, MPH.  
Default value : km/h.



- EX : Set speed unit from km/h to MPH.
- Press the **Down** button to enter the temp. unit setting screen.



- **Example : To set temp. unit to °F.**
- Press the **Up** button to choose the setting options.
- ⚠ **Now the setting value is flashing.**
- NOTE** Setting range : C (Celsius) and °F (Fahrenheit).  
Default value : °C (Celsius).



- EX : Set temp. unit from °C (Celsius) to °F (Fahrenheit).
- Press the **Down** button to go back to the unit screen.

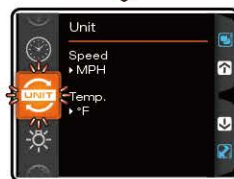

- The unit screen.

## 5-3 Backlight (Mode & Brightness & Color) Settings



- In the backlight screen, press the **Down** button for 3 seconds to enter the background mode setting.



- **Example** : To set the mode to **Night mode**.

- Press the **Up** button to choose the setting options.

⚠ Now the setting value is flashing.

**NOTE** Auto setting (automatically switch according to the light : day mode display for the bright environment and Night mode display for the dark environment), Day mode, Night mode.  
Default value : Auto.



- **EX** : Set background from Auto mode to Night mode.
- Press the **Down** button to enter the backlight brightness (day) setting.



- **Example** : To set the backlight brightness (day) at 4 (80%).

- Press the **Up** button to choose the setting number.

⚠ Now the setting value is flashing.

**NOTE** Setting range : 3/5 ~ 5/5 (Brightest).  
Setting unit : 20% per level.  
Default value : 5/5 (100%).

**NOTE** The backlight brightness will change immediately after you set the value.



- **EX** : The backlight brightness (day) setting is changed from 5/5 (100%) to 4/5 (80%).
- Press the **Down** button to enter the backlight brightness (night) setting.



- **Example** : To set the backlight brightness (night) at 2/5 (40%).
- Press the **Up** button to choose the setting number.

⚠ Now the setting value is flashing.

**NOTE** Setting range : 1/5 (Darkest) ~ 5/5 (Brightest), need  $\leq$  the setting value of backlight brightness (day).  
Setting unit : 20% per level.  
Default value : 3/5 (60%).

**NOTE** The backlight brightness will change immediately after you set the value.



- **EX** : The backlight brightness (night) setting is changed from 3/5 (60%) to 2/5 (40%).

- Press the **Down** button to enter the backlight color setting.



- **Example** : To set backlight color to blue.
- Press the **Up** button to choose the color.

Now the setting value is flashing.

**NOTE** Switch color according to the following order, white, orange, yellow, green, blue.

**NOTE** Default value : White.

**NOTE** The backlight color will change immediately after you set the value.



- **EX** : Set backlight color from white to blue.

- Press the **Down** button to go back to the backlight screen.



- The backlight screen.

## 5-4 Overspeed Warning Settings



- In the overspeed warning screen, press the **Down** button for 3 seconds to enter the overspeed warning setting.



- **Example** : To set overspeed warning value to 80 KPH.

- Press the **Down** button to move to the digit you want to set.

⚠ Now the setting value is flashing.

**NOTE** Setting range : 30~360 km/h (20~225 MPH).  
Default value : 60 km/h (38 MPH).



- Press the **Up** button to choose the setting number.



- **EX** : Set overspeed warning value from 60 KPH to 80 KPH.
- Press the **Down** button to go back to the speed warning screen.



- The overspeed warning screen.

## 5-5 Shift Light Warning Settings



- In the shift light warning screen, press the **Down button for 3 seconds** to enter the shift light warning1(Steady) setting.



- **Example : To set shift light warning2 (Fast Flash) value to 9,000 RPM.**
- Press the **Down button** to move to the digit you want to set.

⚠ Now the setting value is flashing.  
**NOTE** Setting range : 1,000~20,000 RPM.  
 Default value : 8,000 RPM.



- **Example : To set shift light warning1 (Steady) value to 10,000 RPM.**
- Press the **Down button** to move to the digit you want to set.

⚠ Now the setting value is flashing.  
**NOTE** Setting range : 1,000~20,000 RPM.  
 Default value : 9,000 RPM.



- Press the **Up button** to choose the setting number.



- Press the **Up button** to choose the setting number.



- **EX : Set shift light warning2(Fast Flash) value from 8,000 RPM to 9,000 RPM.**
- Press the **Down button** to go back to the shift light warning screen.



- **EX : Set shift light warning1(Steady) value from 9,000 RPM to 10,000 RPM.**
- Press the **Down button** to enter the shift light warning2(Fast Flash) setting.



- The shift light warning screen.

## 5-6 Temp Warning Settings



- In the temp warning screen, press the **Down button for 3 seconds** to enter the overheat warning setting.



- **EX : Set temp warning value from 90 °C to 120 °C.**
- Press the **Down button** to go back to the overheat warning setting.



- **Example : To set temp warning value to 120 °C.**
- Press the **Down button** to move to the digit you want to set.

⚠ Now the setting value is flashing.  
**NOTE** Setting range : 60 ~250 °C  
 (140 ~482 °F).  
 Default value : 90 °C(194 °F).



- The temp warning screen.



- Press the **Up button** to choose the setting number.

## 5-7 Voltage Warning Settings

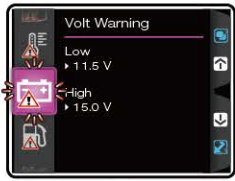

- In the voltage warning screen, press the **Down button** for 3 seconds to enter the low voltage warning setting.



- **Example** : To set low voltage warning value to DC 11.0 V.
- Press the **Up button** to choose the setting number.
- ⚠ **Now the setting value is flashing.**
- NOTE** Setting range : DC 8.0~13.0 V.  
Default value : DC 11.5 V.



- **EX** : Set low voltage warning value from DC 11.5 V to DC 11.0 V.
- Press the **Down button** to enter the high voltage warning setting.



- **Example** : To set high voltage warning value to DC 16.0 V.
- Press the **Up button** to choose the setting number.
- ⚠ **Now the setting value is flashing.**
- NOTE** Setting range : DC 13.1~18.0 V.  
Default value : DC 15.0 V.



- **EX** : Set high voltage warning value from DC 15.0 V to DC 16.0 V.
- Press the **Down button** to go back to the voltage warning screen.



- The voltage warning screen.

## 5-8 Low Fuel Warning Setting



- In the low fuel warning screen, press the **Down button** for 3 seconds to enter the low fuel warning setting.



- **Example** : To set low fuel warning value to 3/6.
- Press the **Up button** to choose the setting number.
- ⚠ **Now the setting value is flashing.**
- NOTE** Setting range : 0/6 ~ 3/6.  
Default value : 1/6.



- **EX** : Set low fuel warning value from 1/6 to 3/6.
- Press the **Down button** to go back to the low fuel warning screen.



- The low fuel warning screen.

## 5-9 Motor Oil Maintenance Setting



- In the motor oil maintenance screen, press the **Down button** for 3 seconds to enter the motor oil maintenance setting.



- Press the **Up button**, and select whether to turn on the motor oil maintenance function.
- Select **ON** to enter the motor oil maintenance setting.
- ⚠ **Now the setting value is flashing.**
- NOTE** Setting range : ON, OFF.  
Default value : ON.



- **Example** : To set motor oil maintenance as 12,000 km.
- Press the **Down button** to move to the digit you want to set.
- ⚠ **Now the setting value is flashing.**
- NOTE** Setting range : 500 ~ 16,000 km (300~10,000 mile).  
Default value : 500 km(300 mile).



- Press the **Up button** to choose the setting number.



- **EX** : The motor oil maintenance setting is changed from 500 km to 12,000 km.
- Press the **Down button** to go back to the motor oil maintenance screen.



- The motor oil maintenance screen.

## 5-10 ABS Warning Settings



- The ABS warning screen, press the **Down button for 3 seconds** to enter the ABS warning setting.



- Press the **Down button** to go back to the ABS warning screen.



- Press the **Up button**, and select whether to turn on the ABS warning function.

⚠ Now the setting value is flashing.

**NOTE** Setting range : ON, OFF.  
Default value : ON.

⚠ When choosing ON, the ABS signal light  will light up.



- The ABS warning screen.

## 5-11 Warning Light Warning Settings



- In the warning light warning screen, press the **Down button for 3 seconds** to enter the warning light warning setting.



- Press the **Down button** to go back to the warning light warning screen.



- Press the **Up button** to choose the setting number.
- Press the **Down button** to confirm selection.

⚠ Now the setting value is flashing.

**NOTE** Setting range : OFF, Slow Flash, Steady, Fast Flash.  
Default value :

1. Overspeed : OFF
2. Shift Light 1 : OFF
3. Shift Light 2 : OFF
4. Temp Warning : OFF
5. Volt Warning : OFF
6. Low Fuel Warning : OFF
7. Trip oil : OFF

**NOTE** Priority setting range :  
1. FF > S > SF / 2. FF > SF > S /  
3. S > FF > SF / 4. S > SF > FF /  
5. SF > FF > S / 6. SF > S > FF  
Default value : FF>S>SF  
※FF=Fast Flash / S=Steady /  
SF=Slow Flash /



- The warning light warning screen.

## 5-12 Tire Circumference And Sensing Point Settings

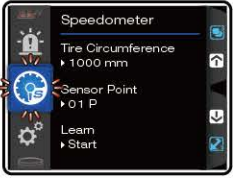

- In the tire circumference and sensing point screen, press the **Down** button for 3 seconds to enter the tire circumference and sensing point setting.
- CAUTION!**
- Measure the tire circumference (The tire you will install the sensor on) and confirm the number of sensor points.
- The speed displayed on the meter will be affected by the setting, make sure the setting number is correct before you enter the setting.
- ⚠ Reset this setting value if you change to a different tire size.



- **Example** : To set the sensor point value to 06 P .
- Press the **Down** button to choose the setting number.
- ⚠ Now the setting value is flashing.
- NOTE** Setting range : 01 P~40 P.  
Default value : 01 P.

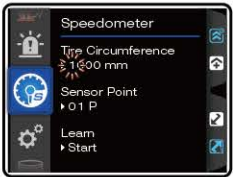

- **Example** : If the tire circumference is 1,300 mm.
- Press the **Down** button to choose the setting number.
- ⚠ Now the setting value is flashing.
- NOTE** Setting range : 300~2,500 mm.  
Default value : 1,000 mm.



- Press the **Up** button to choose the setting number.
- EX : Set the sensor point value from 01 P to 06 P.
- Press the **Down** button to enter the learning mode setting.



- Press the **Up** button to start the learning mode.

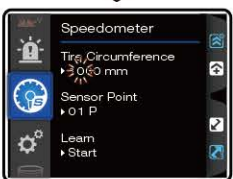

- Press the **Up** button to choose the setting number.



- Ride for 1 km(1 mile); after the arrival, press the **Down** button for 3 seconds. Complete learning by returning to the tire circumference and sensing point screen.
- Press the **Up** button for 3 seconds to cancel learning.
- NOTE** When mile is set for the unit, ride for 1 mile.

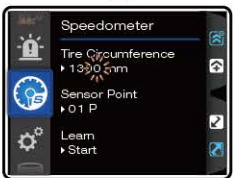

- EX : Set the tire circumference value from 1,000 mm to 1,300 mm .
- Press the **Down** button to enter the sensor point setting.

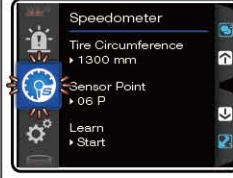

- The tire circumference and sensing point screen.

## 5-13 Gear Settings



- In the gear screen, press the **Down** button for 3 seconds to enter the gear setting.



- Press the **Up** button to start the gear-learning setting.
- NOTE** Enter the Learning Mode, and learn the Gear position according to the speed and RPM.



- **Example** : You want to set the gear setting to ON.
- Press the **Up** button to choose the setting options.
- ⚠ Now the setting value is flashing.
- NOTE** Setting range : ON, OFF.  
Default value : ON.
- NOTE** Select OFF to return to the gear screen.



- In the gear-learning setting.
- CAUTION!** Before setting, be sure to put your motor in Neutral to avoid error detection.
- CAUTION!** "Fail" on the screen means error detection, re-set Gear-Learn.
- CAUTION!** If gear learning is not required, press **Up** and hold for 3 seconds to cancel the gear learning.



- EX : Set the gear setting to ON.
- Press the **Down** button to enter the gear-learning setting screen.



- When N→1 appears, change to Gear 1 to ride. When Gear 1 is detected, 1→2 appears and then change to Gear 2.



- 1 → 2 ○ Change to Gear 2.
- 2 → 3 ○ Change to Gear 3.
- 3 → 4 ○ Change to Gear 4.
- 4 → 5 ○ Change to Gear 5.
- 5 → 6 ○ Change to Gear 6.

---



- After reaching and finishing Gear 4, wait for a few seconds to end gear-learning and return to the gear screen.



- The gear screen.

## 5-14 RPM (Pulse & signal & Range) settings

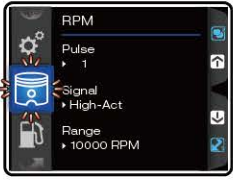

- In the RPM screen, press the Down button for 3 seconds to enter the RPM input pulse setting.

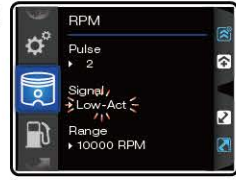

- EX : Set the signal impulse from High-Act to Low-Act.
- Press the Down button to enter the RPM Range setting.

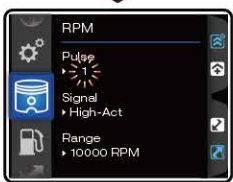

- Example : You want to set the RPM input pulse to 2 (4 Stroke, 4 piston).
- Press the Up button to choose the setting number.
- ⚠ Now the setting value is flashing.



- Example : Set the RPM Range to 15,000 RPM.
- Press the Up button to choose the setting options.
- ⚠ Now the setting value is flashing.

**NOTE** Setting range : P-0.5, 1.0~24.0.  
Default value : 1.0.

**NOTE** Setting range : 10,000 RPM/ 12,000 RPM/ 15,000 RPM/ 18,000 RPM/ 20,000 RPM.  
Default value : 10,000 RPM.

The setting value	The corresponding stroke and pistons number.	The corresponding RPM signal number per ignition.
0.5	— 4C-1P	2 RPM signals per 1 ignition.
1.0	2C-1P 4C-2P	1 RPM signal per 1 ignition.
2.0	2C-2P 4C-4P	1 RPM signal per 2 ignition.
3.0	2C-3P 4C-6P	1 RPM signal per 3 ignition.
4.0	2C-4P 4C-8P	1 RPM signal per 4 ignition.
5.0	— 4C-10P	1 RPM signal per 5 ignition.
6.0	2C-6P 4C-12P	1 RPM signal per 6 ignition.

**CAUTION!**  
Most of the 4-cycle bikes with one single piston are igniting once every 360 degree, so the setting should be the same as the bike with 2-cycle and one piston engine.

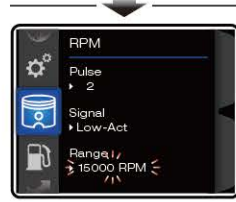

- EX : The RPM Range setting is changed from 10,000 RPM to 15,000 RPM.
- Press the Down button to go back to the RPM screen.



- EX : The RPM input pulse setting is changed from 1.0 to 2.0.
- Press the Down button to enter the signal impulse setting.



- The RPM screen.

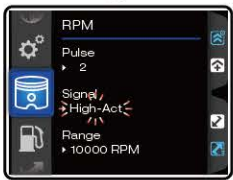

- Example : Set the signal impulse to Low-Act.
- Press the Up button to choose the setting options.
- ⚠ Now the setting value is flashing.

**NOTE** Setting range : High-Act, Low-Act.  
Default value : High-Act.

## 5-15-1 Fuel Resistance( $\Omega$ ) Settings

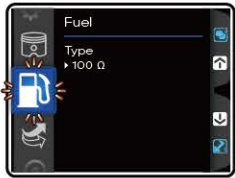

- In the fuel resistance( $\Omega$ ) screen, press the **Down** button for 3 seconds to enter into the fuel resistance( $\Omega$ ) setting.



- EX : Set fuel meter's resistance value from 100  $\Omega$  to 270  $\Omega$ .
- Press the **Down** button to go back to the fuel screen.



- **Example:** If the vehicle is a **YAMAHA FORCE 155**, its resistance is 270  $\Omega$  according to the service manual.
- Press the **Up** button to choose the setting number.

⚠ Now the setting value will blink.

**NOTE** Settings range : 100  $\Omega$ , 250  $\Omega$ , 270  $\Omega$ , 390  $\Omega$ , 510  $\Omega$ , 1200  $\Omega$ , Switch, Custom, OFF.  
Default value : 100  $\Omega$ .

**NOTE** If the setting is Custom, it will enter the 5-15-2(Manual) and 5-15-3 (Auto) operation setting.



- The fuel resistance( $\Omega$ ) screen.

## 5-15-2 Fuel Gauge Resistance Settings (Manual)



- Press the **Down** button twice to enter the fuel gauge resistance setting (Manual).



- **Example :** To set the highest fuel level resistance value as 10  $\Omega$ .

- Press the **Down** button to move to the digit you want to set.

⚠ Now the setting value is flashing.



- **Example :** To set the lowest fuel level resistance value as 90  $\Omega$ .
- Press the **Down** button to move to the digit you want to set.

⚠ Now the setting value is flashing.



- Press the **Up** button to choose the setting number.



- Press the **Up** button to choose the setting number.



- EX : Set the highest fuel level resistance value to 10  $\Omega$ .
- Press the **Down** button to go back to the fuel gauge resistance screen.



- EX : Set the lowest fuel level resistance value from 80  $\Omega$  to 90  $\Omega$ .
- Press the **Down** button twice to enter the highest fuel level resistance setting.



- The fuel gauge resistance screen.

### 5-15-3 Fuel Gauge Resistance Settings (Auto Detection)



- Press the **Down** button to enter the fuel gauge resistance setting (Auto detection).

**CAUTION!**

- Before detection, ensure that your current fuel level is in the lowest position that you would like to have.
- Stop the vehicle for a few seconds to allow the fuel surface to become steady, then start the detection of the resistance.

**P.S.**



- When the fuel surface sensor floats in the lowest position then press the **button**, it will detect the resistance around 90 Ω.

The lowest position



- EX : Auto detection the lowest fuel level resistance value is 90 Ω.
- Hold and press the **Down** button 5 times to enter the highest fuel level resistance auto detection screen.

**P.S.**



The highest position

- When the fuel surface sensor floats in the highest position then press the **button**, it will detect the resistance around 10 Ω.



- EX : Auto Detection the highest fuel level resistance value is 10 Ω.
- Press the **Down** button to go back to the fuel gauge resistance screen.



- The fuel gauge resistance screen.

### 5-16 A/F Ratio Settings

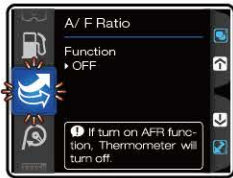

- The A/F ratio screen, press the **Down** button for 3 seconds to enter the A/F ratio setting.

**NOTE** To use the A/F ratio function, you will need to install related accessories and wiring.



- Press the **Down** button to go back to the A/F ratio screen.



- Press the **Up** button, and select whether to turn on the A/F ratio warning function.

⚠ Now the setting value is flashing.

**NOTE** Setting range : ON, OFF. Default value : OFF.

⚠ If turn on AFR function, Thermometer will auto turn off.



- The A/F ratio screen.

### 5-17 Power Test Setting



- In the Power Test screen, press the **Down** button for 3 seconds to enter the Power Test setting.



- EX : Set target speed value from 50 km/h to 110 km/h.
- Press the **Down** button to enter the target distance setting.



- Example : To set target speed value to 110 km/h.
- Press the **Up** button to choose the setting number.

⚠ Now the setting value is flashing.

**NOTE** Setting range : 30~360 km/h (20~225 MPH). Default value : 50 km/h (30 MPH).



- Example : To set target distance value to 100 m.
- Press the **Up** button to choose the setting number.

⚠ Now the setting value is flashing.

**NOTE** Setting range : 50~1,500 m (1/32~30/32 mile). Default value : 50 m (1/32 mile).



- EX : Set target distance value from 50 m to 100 m.
- Press the **Down** button to enter the the sort by setting.



- EX : Set sort by from Sequence to Best.
- Press the **Down** button to go back to the Power Test screen.



- Example** : To set sort by to Best.
- Press the **Up** button to choose the setting options.

⚠ Now the setting value is flashing.

**NOTE** Setting range : Sequence, Best.  
Default value : Sequence.



- The Power Test screen.

## 5-18 Internal And External ODO Settings



- In the internal and external ODO screen, press the **Down** button for 3 seconds to enter the external ODO setting.

⚠ User unable to adjust or clear internal ODO.

**NOTE** Display range : 0~999,999 km (mile).



- EX : Set external total distance value from 0 km to 12,500 km.
- Press the **Down** button to go back to the internal and external ODO screen.



- Example** : To set external total distance value to 12,500 km.
- Press the **Down** button to move to the digit you want to set.

⚠ Now the setting value is flashing.

**NOTE** Cursor's order : one hundred thousand→thousands→thousand→hundred→ten→digit.

**NOTE** Setting range : 0 ~ 999,999 km (mile).



- The internal and external ODO screen.



- Press the **Up** button to choose the setting number.

## 5-19 Meter Information Settings



- In the meter information screen, press the **Down** button for 3 seconds to enter the meter information setting.



- Press the **Down** button to confirm reset.
- Press the **Up** button to cancel reset.



- Example** : To reset the meter(original setting).
- Press the **Up** button to reset.

⚠ Now the setting value is flashing.

**NOTE** User unable to adjust or clear software Version.



- Successfully reset and return to the boot screen for initial use.

## 6 Troubleshooting

The following situations do not indicate malfunction of the product. Check the following before taking it in for repair.

Trouble	Check item	Trouble	Check item
The meter doesn't work when the power is on.	<ul style="list-style-type: none"> <li>●The power isn't supplied to the meter.</li> <li>→Make sure the wiring is connected. The wiring and fuse are not broken.</li> <li>→The battery is too old to supply needed power (DC 12 V).</li> </ul>	A/F ratio doesn't appear or appears incorrectly.	<ul style="list-style-type: none"> <li>●Check the setting.</li> <li>→Refer to the manual 5-16 A/F ratio setting.</li> </ul>
The meter shows wrong information. Speed meter doesn't appear or appears incorrectly.	<ul style="list-style-type: none"> <li>●Check the voltage of your battery, and make sure the voltage is over DC 12 V.</li> <li>●May be poor connection of the speed sensor.</li> <li>→Check the speed sensor is connected correctly.</li> <li>●Check the setting.</li> <li>→Refer to the manual 5-12 circumference and sensing point setting.</li> </ul>	Fuel meter doesn't display or display error.	<ul style="list-style-type: none"> <li>●Check your fuel tank.</li> <li>●May be poor connection of the harness.</li> <li>→Make sure the wires are connected correctly.</li> <li>●Check the setting.</li> <li>→Check the settings menu, the fuel settings are correct.</li> </ul>
Tachometer doesn't appear or appears incorrectly.	<ul style="list-style-type: none"> <li>●Make sure the RPM wire is connected properly.</li> <li>→Check the RPM wire wire is connected correctly.</li> <li>●Check the spark plug is R type or not. If not, replace the spark plug with the R type spark plug.</li> <li>●Check the setting.</li> <li>→Refer to the manual 5-14 RPM input pulse , signal impulse.</li> </ul>	The clock is incorrect.	<ul style="list-style-type: none"> <li>●Check the setting.</li> <li>→Check in the settings menu if the clock settings are correct.</li> <li>●May be due to a reversed power line.</li> <li>→Check if the positive wire(Red) connects to the battery(DC 12 V) and if the main switch positive wiring(Brown) connects to the main switch(DC 12 V).</li> </ul>
Thermometer doesn't appear or appears incorrectly.	<ul style="list-style-type: none"> <li>●Make sure the temperature wire is connected properly.</li> <li>→Check if the temperature wire is connected correctly.</li> <li>●Check the setting.</li> <li>→Refer to the manual 5-6 temp warning setting.</li> </ul>	Voltage doesn't appear or appears incorrectly.	<ul style="list-style-type: none"> <li>●May be due to poor connection of wiring.</li> <li>→Check whether the wires are disconnected or have fallen off.</li> </ul>
		The meter indicator doesn't display.	<ul style="list-style-type: none"> <li>●May be poor connection of the harness.</li> <li>→Make sure the wires are connected correctly.</li> </ul>

※ If the problems still cannot be solved, contact our technical department for assistance.