



Thank you for purchasing our product. Please, read the instructions thoroughly and retain them for future reference.

⚠ NOTICE

- To install, follow the steps as described in the manual. Any damages caused by not following directions voids warranty.
- Correct tools must be used for installation.
- Do not modify any parts unless specifically stated in the instruction manual.
- Interior controll maintenance should be performed by a professional only.

©MARK MEANING:

NOTE You could get the installation details from the information behind the mark.

⚠ Some processes must be followed to avoid the affection caused by wrong installation.

⚠ **WARNING!** Some processes must be followed to avoid damages to yourself or the public.

⚠ **CAUTION!** Some processes must be followed to avoid the damage to the vehicle.

🔧 Denotes the tightening torque value

1 ACCESSORIES

1 GT Front Fender X1

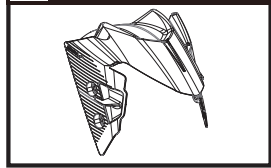

2 Adjustment piece X4

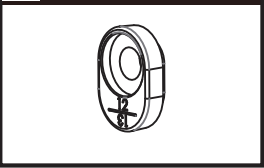

3 Cushion block X4

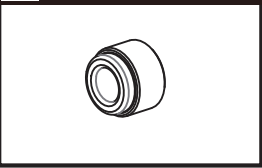

4 Hex Screw X4
M6x35LxP1.0

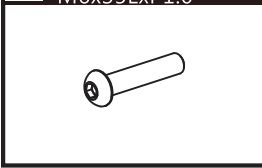

5 bushing X4

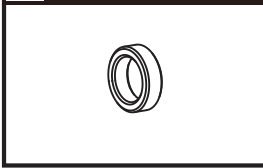

NOTE Please contact the local distributor if the items you open are not the same, as the above-listed one.

2 INSTALLATION INSTRUCTION

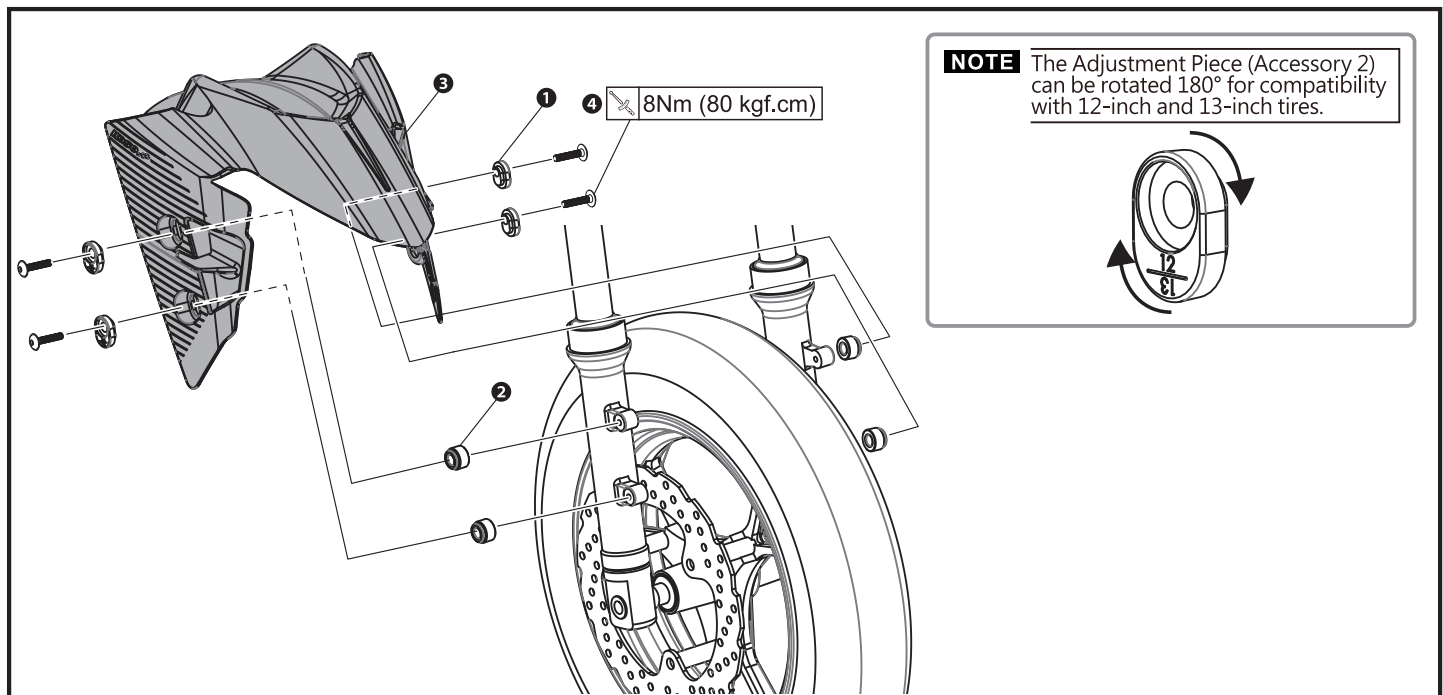

NOTE The Adjustment Piece (Accessory 2) can be rotated 180° for compatibility with 12-inch and 13-inch tires.

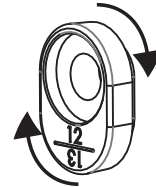

PLEASE PROCEED AS FOLLOWS

1. Use appropriate tools to remove the original front bumper.
2. Attach ① adjustment pieces x4 (Accessory 2) from the outside and ② Cushion block x4 (Accessory 3) from the inside to ③ GT front bumper.
3. Align the installed front bumper to the corresponding points, and use appropriate tools to attach ④ hex screws x4 (Accessory 4) to the GT front bumper.