

**KOSO** 

-  No. 406 DING-AN ST. ANNAN DISTRICT TAINAN CITY 70944 TAIWAN
-  +886-6-2556565
-  +886-6-2461878
-  [www.koso.com.tw](http://www.koso.com.tw)
-  [info@koso.com.tw](mailto:info@koso.com.tw)

**KOSO NORTH AMERICA** 

-  673 Rossiter st. St-Jean-sur-Richelieu, Qc, Canada, J3B 8A4
-  +1-450-359-0604
-  +1-450-359-0849
-  [www.kosonorthamerica.com](http://www.kosonorthamerica.com)
-  [info@kosonorthamerica.com](mailto:info@kosonorthamerica.com)

**KOSO EUROPE** 

-  Dr.-Walter-Bruch-Strasse 9 66606 St.Wendel
-  +49 6851 978720
-  +49 6851 978799
-  [www.kosoeurope.com](http://www.kosoeurope.com)
-  [info@kosoeurope.com](mailto:info@kosoeurope.com)



While all the efforts have been made to ensure that the information contained in this catalog is correct, Tong Yah Electronic Technology Co., Ltd. will not accept the liability for errors or omissions. Technical specifications and data are provided for guidance only. All rights are strictly reserved. Products shown in this catalog are protected by international patents. While copying this publication (in whole or in part) without written consent from Tong Yah Electronic Technology Co., Ltd. is strictly forbidden and punishable by law. Because we constantly aim to improve our products, we reserve the right to amend or alter at any time and without prior notice the specifications of any item detailed in this publication.

**ED24**  
— SINCE 1981 —

**Tong Yah Electronic Technology Co., Ltd**

Establishment **1981**

Staff **240**

Business activities **Motorcycle & Automobile meters  
Motorcycle & Automobile electronic parts  
Scooter & motorcycle tune-up parts  
Scooter & motorcycle accessory parts**

Quality certification

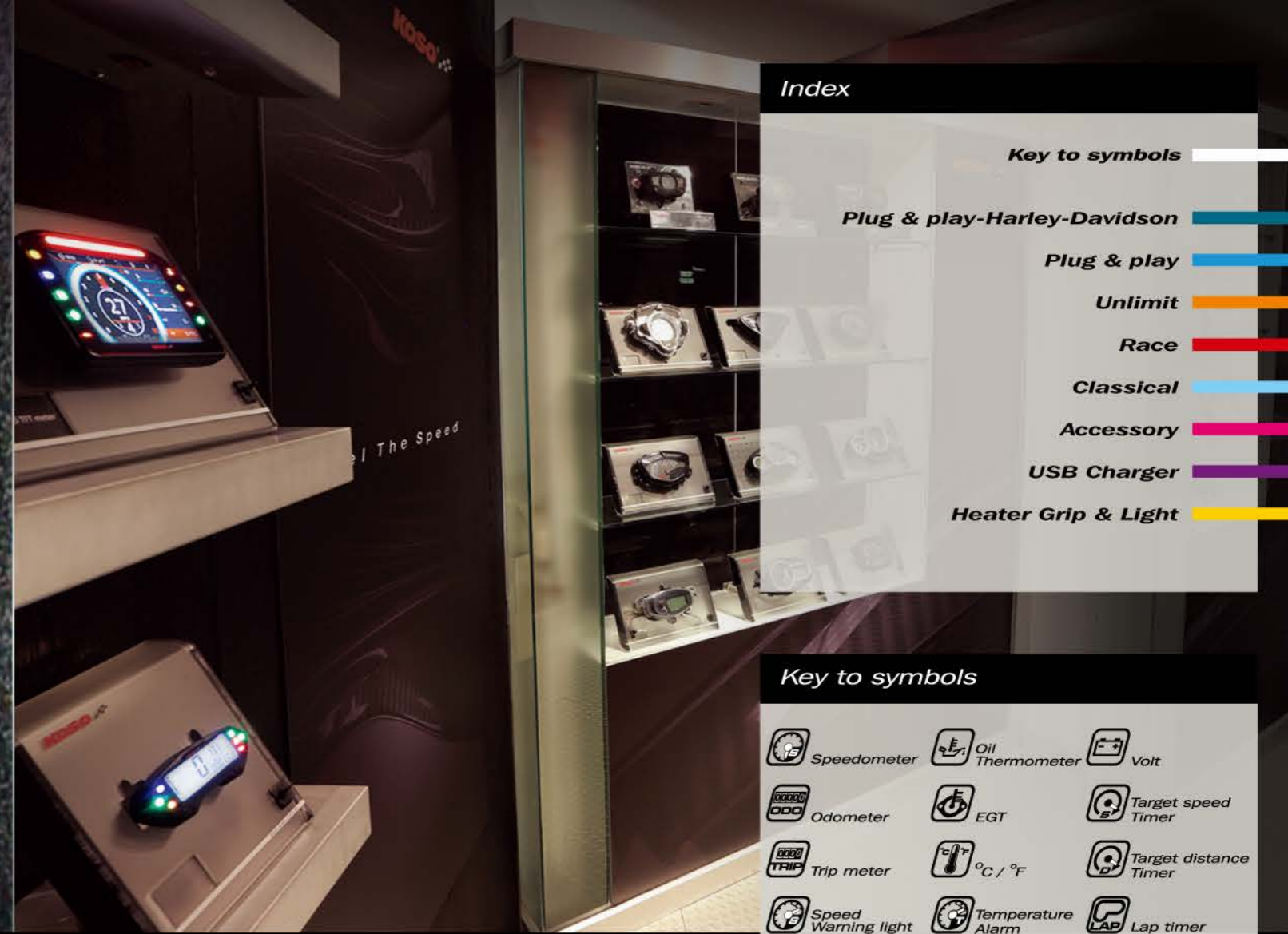

**Index**

**Key to symbols**

- Plug & play-Harley-Davidson
- Plug & play
- Unlimit
- Race
- Classical
- Accessory
- USB Charger
- Heater Grip & Light

**Key to symbols**

Speedometer	Oil Thermometer	Volt
Odometer	EGT	Target speed Timer
Trip meter	°C / °F	Target distance Timer
Speed Warning light	Temperature Alarm	Lap timer
Tachometer	Air / fuel ratio	JIS D 0203
Shift light	Gear meter	Back light
Hour meter	Fuel	
Water Thermometer	Clock	



Private design center



Private tooling-making dept.

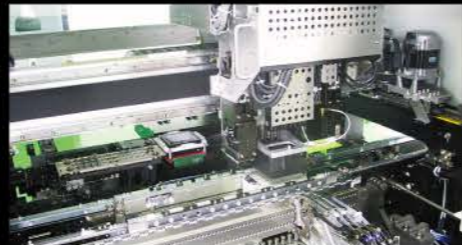

Private production line



Private Test Equipment



Easily adaptable production

Plug & play

# Harley-Davidson HD-02

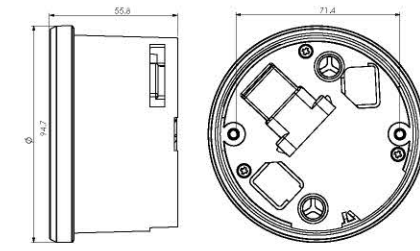

● Digital tachometer	Display range: 0 ~ 9990 rpm
○ Tachometer	Display range: 0 ~ 8000 rpm
	Display unit: 166 rpm
● Engine temperature	Display range: -17 ~ 123 °C (0 ~ 255 °F)
● Gear meter	Display range: N, 1 ~ 6
● Supply voltage	DC 12 V
● Effective temperature range	-10 ~ +60 °C
● Meter standard	JIS D 0203
● Meter size (D X H)	D94.7 X 55.8 mm
● Meter weight	
● Indicator light color	Cruise Control Light (Orange/Green) ABS Light (Yellow)

## HD-02R 4" Tachometer

Our plug & play 0 to 8 000 RPM meter is equipped with a 2 colors changeable LCD display. Other than providing the engine RPM, this meter will provide the gear position, cruise control and ABS indicator light. Easy to connect and install, this meter is a great addition to all Harley's FLHT, FLHX and FLTR from 2004 to 2013.

Item number	Backlight color	Display range	Casing
-------------	-----------------	---------------	--------



* BA 0 5 1 1 0 0 *	* BA 0 5 1 1 1 0 *
Blue/Red 0~8,000 Chrome	Blue/Red 0~8,000 Black



## Plug & play

### HD-02S 4" Speedometer

Our plug & play multi-functions speedometer is equipped with a 2 colors changeable LCD display. The instrument cover the basic functions of speed, odometer and tripmeter. It also includes a clock and all the necessary indicator lights. Easy to connect and install, this meter is a great addition to all Harley's FLHT, FLHX and FLTR from 2004 to 2013.

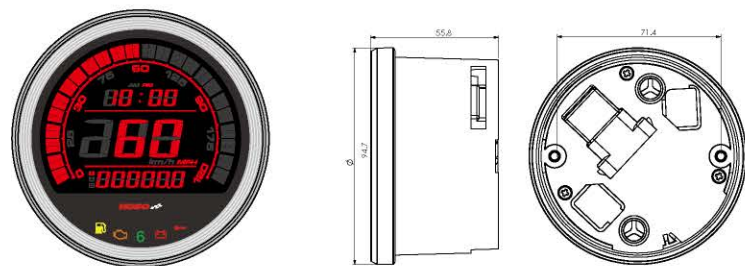

- Digital Speedometer Display range: 0 ~ 299 km/h (0 ~ 199 mph)  
Display unit: 1 km/h (mph)
- Speedometer Display range: 0 ~ 200 km/h (0 ~ 120 mph)  
Display unit: About 4.2 km/h (2.5 mph)
- Odometer Display range: 000,000 ~ 999,999 km (mile)  
Display unit: 1 km (mile)
- Trip meter A/B Display range: 0000.0 ~ 9999.9 km (mile)  
Display unit: 0.1 km (mile)
- Clock Display range: 12 H / 24 H  
Accuracy +/- 4 seconds / Day
- Fuel Display range: Fu-04 / Fu-08  
Hd-04 / Hd-08
- Backlight color Setting range: Blue / Red
- Effective voltage DC 12 V
- Effective temperature range -10 ~ +60 °C
- Meter standard JIS D 0203
- Meter size (D X H) D94.7 X 55.8 mm
- Meter weight
- Indicator light color Fuel light (Yellow)  
Engine Light (Yellow)  
Gear Light (Green)  
Volt Light (Red)  
Anti-Theft Light (Red)

Item number  
Backlight color Display range Casing



\* BA 05 10 00 \*



\* BA 05 10 10 \*

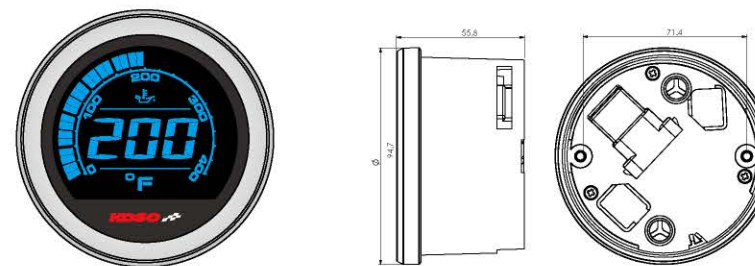

- Oil temperature Display range: 0 ~ 400 °F  
Display unit: 1 °F or 1 °C
- Oil temp. warning Setting range: 150 ~ 400 °F (70 ~ 199 °C)  
Setting unit: 1 °F or 1 °C
- Supply voltage DC 12V
- Backlight setting Setting range: Blue / Red
- Effective temperature range -10 ~ +60 °C
- Meter standard JIS D 0203
- Meter size (D X H) D57.5 X 47.3 mm
- Meter weight 86 g

Item number  
Backlight color Display range Casing



\* BA 05 05 00 \*



\* BA 05 05 10 \*

### HD-02P 2" Oil Temperature

This plug & play oil temperature meter is equipped with a 2 color changeable LCD display. It will provide you with the oil temperature from 0 to 400 °F and is easy to connect and install. This meter is a great addition to all Harley's FLHT, FLHX and FLTR from 2004 to 2013. This meter could allow ride to replace the Ambient meter if the ambient temp. is less important by personal preference.



## Plug & play

### HD-02P 2" Ambient Temperature

Equipped with a 2 colors changeable LCD display, this plug & play ambient temperature meter will provide you the outside temperature from 0 to 120°F. Easy to connect and install, this meter is a great addition to all Harley's FLHT, FLHX and FLTR from 2004 to 2013.

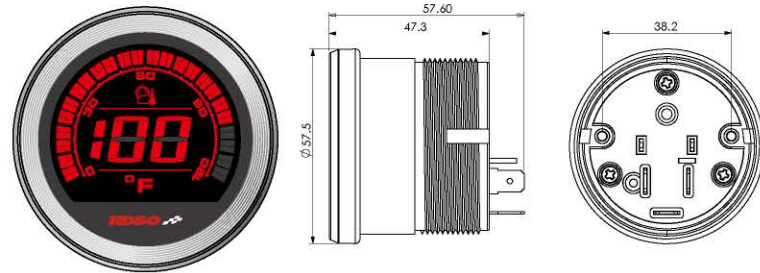

● Ambient Temperature	Display range: 0~120 °F
	Display unit: 1 °F
● Temperature alarm	Setting range: 15~65 °F
	Setting unit: 1 °F
● Supply voltage	DC 12V
● Effective temperature range	-10~+60°C
● Meter standard	JIS D 0203
● Meter size (D X H)	D57.5 X 47.3 mm
● Meter weight	Around 190 g



### HD-02P 2" Oil Pressure Meter

Equipped with a 2 colors changeable LCD display, this plug & play oil pressure meter will provide the engine oil pressure from 0 to 60 PSI. Easy to connect and install, this meter is a great addition to all Harley's FLHT, FLHX and FLTR from 2004 to 2013.

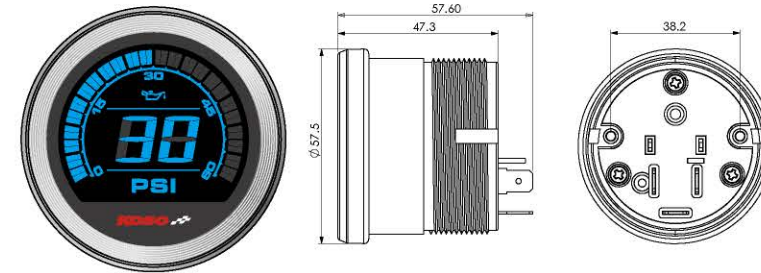

● Oil press	Display range: 0~60 PSI
	Display unit: 1 PSI
● Oil press alarm	Setting range: 5~60 PSI
	Setting unit: 0.1 PSI
● Supply voltage	DC 12V
● Effective temperature range	-10~+60°C
● Meter standard	JIS D 0203
● Meter size (D X H)	D57.5 X 47.3 mm
● Meter weight	Around 190 g



Item number  
Backlight color Display range Casing



\*BA0500000\* Blue/Red 0~120°F Chrome  
\*BA0500200\* Blue/Red 0~120°F Black

Item number  
Backlight color Display range Casing



\*BA0504100\* Blue/Red 0~120°F Chrome  
\*BA0504300\* Blue/Red 0~120°F Black





Plug & play

# Harley-Davidson HD-03



010 / 011

NEW!



- Speedometer Display range : 0 ~ 299 km/h (0~199 MPH) switchable
- Overspeed warning Setting range : 30 ~ 299 km/h (19 ~ 199 MPH) when above(including) setting value, warning light will lit.
- Max. speed record Display range : 0 ~ 299 km (mile)
- Internal and external odometer Display range : 0 ~ 999,999 km (mile)
- Tire circumference Setting range : 50 ~ 210 %
- Trip meter A \ B Display range : 0 ~ 9,999.9 km (mile)
- Millage maintenance Setting range : off \ 500 ~ 16,000 km ~ -999 km (mile)
- Gear meter Display range : off \ N \ P \ R \ 1~6
- Tachometer Display range : 0 ~ 9,990 RPM
- RPM shift light Display range : 2,000 ~ 8,000 RPM
- Max. rotating speed Display range : 0 ~ 8,000 RPM
- Engine temperature Setting range : -40 ~ 300 °C (-40 ~ 572 °F)
- Fuel meter Setting range : HD Std \ Cust
- Fuel warning setting Setting range : 1. HD Standard - LCD flashing as warning when Fuel level resistance greater than 211Ω, and will turn off when resistance smaller than 187Ω.  
2. Customize - LCD flashing as warning when Fuel level lower than 20%, and will turn off when fuel level higher than 30%.
- Fuel tank volume Setting range : OFF/ 1.0 ~ 9.9 US gallons
- Average fuel consumption Setting range : OFF \ L/100km \ km/L \ MPG \ MPG
- RANGE / Remaining Mileage Display range : 0 ~ 9,999 km (6,249 mile)
- RANGE / Remaining Mileage Warning Display range : LCD shows "LO RNG" and flashing as warning when RANGE / Remaining Mileage lower than 16km (10miles).
- Clock Setting range : 12 / 24 hour format
- Oil Temp. Display range : 0 ~ 400 °F (32 ~ 248 °C )
- Voltmeter Display range : 8 ~ 18 V
- Backlight brightness Setting range : 1 ~ 5 (darkest) ~ 5 / 5 (brightest)
- Backlight color Setting range : white, red, orange, yellow, green, blue, light blue, purple
- Operating voltage DC 12 V
- Temperature range JIS D 0203 (S2)
- Indication light
 

Left indicator light (Green)	←	Fog Light (Green)	→
Vehicle hold control (Orange)	⊞	TPMS (Orange)	⊞
Security Indicator (Red)	⊞	Temperature warning (Red)	⊞
Warning Light (Orange/Green)	⊞	Cruise control (Amber/Green)	⊞
Traction control (Orange)	⊞	ABS (Orange)	⊞
Rain mode (Blue)	⊞	High beam (Blue)	⊞
Oil pressure (Red)	⊞	Engine warning (Orange)	⊞
Photometric Sensing	●	Right indicator light (Green)	→

Item number  
Backlight color Display range Casing

* BA 0 6 4 9 0 2 *			
Blue	0~299 km/h	Black	

## KOSO Harley Touring 4pcs Kit For 2014+

Our plug & play multifunction speedometer & tachometer kit is equipped with a 2 color changeable LCD display. These meters provide the basic function of speed, RPM, gear position, odometer and tripmeter. They also include a clock and all the necessary indicator lights and are easy to connect and install. These meters are a great addition to all Harley-Davidson® FLHX, FLTC and FLTR 2021+.



Plug & play 2024

Harley-Davidson HD-03

FOR 2021+ SPEEDO & TACHO / OIL TEMP. / FUEL LEVEL

Plug & play

# Harley-Davidson HD-04



● Speedometer	Display range : 0 ~ 360 km/h (0 ~ 255 MPH) switchable Display unit: 1 km/h (MPH)
○ Display interval	< 0.5 second
○ Internal and external odometer	Display range : 0 ~ 999,999 km (mile) return to zero upon exceed Display unit : 1 km (mile)
○ Trip meter A, B	Display range : 0 ~ 9,999.9 km (mile) returns to zero upon exceed Display unit : 0.1 km (mile)
○ Tire circumference	Setting range : 50 ~ 210 % Setting unit : 1 %
● Gear meter	Display range : off, highest gear, N and highest gear, show all (N / 1 ~ 6)
● Tachometer	Display Range : 0 ~ 8,000 RPM
○ RPM shift light	Setting range : 2,000 ~ 8,000 RPM Warning lights on when exceed setting value (including). Setting unit : 100 RPM
○ Max. RPM warning mode	Setting range : F-OFF (Lit.), F-ON (blink)
● Engine temperature	Setting range : -40 ~ 300 °C (-40 ~ 572 °F)
● Fuel meter	Display range : off, original fuel kit (PN 6120008A), Sportster fuel switch, Dyna
○ Fuel tank volume	Setting range : OFF / 1.0 ~ 9.9 US gallons
○ Average fuel consumption	Display range : OFF / L/100km · km/L · MPG (US spec.) · MPG (UK spec.)
● Clock	Setting range : 12 / 24 hour format
● Voltmeter	Display range : 8 ~ 18 V
● Backlight brightness	Setting range : 1 / 5 (darkest) ~ 5 / 5 (brightest)
○ Backlight color	Setting range : red, orange, yellow, green, blue, light blue, purple, white
● Millage maintenance	Setting range : Off, 500 ~ 16,000 km (300 ~ 10,000 mile) Setting unit : 100 km (mile)
● Operating voltage	DC 12 V
● Temperature range	-10 ~ +60 °C
● Specifications	JIS D 0203 (S2)
● Meter size	D94.7 X 55.8 mm
● Meter weight	165 grams
● Indication light	RPM shift light (Red light) ● Low fuel warning light (Yellow light) ⛽ Engine check light (Yellow light) ⚠ Battery discharge light (Red light) 🔋 Security light (Red light) 🚫 Cruise light (Orange / Green light) 🚦 ABS light (Yellow light) 🚗

## HD-04 Harley Sportster Meter For 04'-13' / 2014+ Meter

You can now customize your sportster with our high-quality plug & play meter that is equipped with a 8 color changeable LCD display. Some of the great functions this meter has to offer are : speed, RPM, indicator lights, fuel level, and gear position indicator. Available in silver or black bezel.



Item number  
LCD Models Bezel



* B A 0 5 1 2 0 0 *	Negative	04'-13'	Silver
* B A 0 5 1 2 0 1 *	Positive	04'-13'	Silver
* B A 0 5 1 2 1 0 *	Negative	04'-13'	Black
* B A 0 5 1 2 1 1 *	Positive	04'-13'	Black

Fits XL-883 & XL-1200  
2004 to 2013 & Dyna 2004-2011

* B A 0 5 1 2 2 0 *	Negative	2014+	Silver
* B A 0 5 1 2 2 1 *	Positive	2014+	Silver
* B A 0 5 1 2 3 0 *	Negative	2014+	Black
* B A 0 5 1 2 3 1 *	Positive	2014+	Black

Fits XL-883 & XL-1200  
2014+, Softail 2011+ & Dyna 2012+



Plug & play

# Harley-Davidson HD-05



014 / 015



●Speedometer	Display range : 0 ~ 360 km/h (0 ~ 225 MPH) switchable Display unit : 1 km/h (MPH)
○Display interval	< 0.5 second
○Internal and external odometer	Display range : 0 ~ 999,999 km (miles) return to zero upon exceeding Display unit : 1 km (mile)
○Trip meter A,B	Display range : 0 ~ 9,999.9 km (miles) returns to zero upon exceeding Display unit : 0.1 km (mile)
○Tire circumference	Setting range : 50 ~ 210 % Setting unit : 1 %
●Gear meter	Display range : off, highest gear, N and highest gear, show all (N / 1 ~ 6)
●Tachometer	Display Range : 0 ~ 8,000 RPM
○RPM shift light	Setting range : 2,000 ~ 8,000 RPM Warning lights on when exceed setting value (including). Setting unit : 100 RPM
○Max. RPM warning mode	Setting range : F-OFF (Lit.), F-ON (blink)
●Engine temperature	Setting range : -40 ~ 300 °C (-40 ~ 572 °F)
●Fuel meter	Display range: off, Dyna
○Fuel tank volume	Setting range : OFF/ 1.0 ~ 9.9 US gallons
○Average fuel consumption	Display range : OFF / L/100 km · km/L · MPG (US spec.) · MPG (UK spec)
●Clock	Setting range : 12 / 24 hour format
●Voltmeter	Display range : 8 ~ 18 V
●Backlight brightness	Setting range : 1 / 5 (darkest) ~ 5 / 5 (brightest)
○Backlight color	Setting range : red, orange, yellow, green, blue, light blue, purple, white
●Mileage maintenance	Setting range : Off, 500 ~ 16,000 km (300 ~ 10,000 mile) Setting unit : 100 km (miles)
●Operating voltage	DC 12 V
●Temperature range	-10 ~ +60 °C
●Specifications	JIS D 0203 (S2)
●Meter size	D117 X 45 mm
●Meter weight	208.5 grams
●Indication light	RPM shift light (Red light) ● Low fuel warning light (Amber light) ⚡ Engine check light (Amber light) ⚠ Battery discharge light (Red light) 🔋 Security light (Red light) 🔒 Cruise light (Amber / Green light) 🚦 ABS light (Amber light) 🚗

## HD-05 Harley Dyna Meter For 04'-13' / 2014+ Meter

The all-new 100% plug and play HD-05 series for 4 1/2" gas tank mounted Harley-Davidson models features a tach and speedo combo with a programmable shift light with gear indicator. This gauge also features vital readings such as engine temperature and battery voltage along with average fuel economy and a complete system of indicators to monitor your bikes vital signs.



Item number	Models	Bezel
-------------	--------	-------



* BA 07 20 00 *	Positive	2014+	Silver
* BA 07 20 01 *	Negative	2014+	Silver
* BA 07 20 10 *	Positive	2014+	Black
* BA 07 20 11 *	Negative	2014+	Black

2012 to newer Dyna models  
2011 to newer Softails models  
2014 to newer Road King models

* BA 07 21 00 *	Positive	04'-13'	Silver
* BA 07 21 01 *	Negative	04'-13'	Silver
* BA 07 21 10 *	Positive	04'-13'	Black
* BA 07 21 11 *	Negative	04'-13'	Black

2004 to 2011 Dyna models  
2004 to 2010 Softails models  
2004 to 2013 Road King models

Plug & play 2024

Harley-Davidson HD-05

FOR 04'-13' / 2014+ METER

Plug & play

# Harley-Davidson HD-06



NEW!



● Speedometer	Display range : 0 ~ 299 km/h (0~199 MPH) switchable Display unit : 1 km/h (MPH)
○ Display interval	<0.5 second
○ Overspeed warning setting	Setting range : 30 ~ 299 km/h (19 ~ 199 MPH) when above(including) setting value, warning light will lit. Setting unit : 1 km/h (MPH)
○ Max. speed record	Display range : 0 ~ 299 km (0 ~ 199mile)
○ Internal and external odometer	Display range : 0 ~ 999,999 km(mile) Display unit : 1 km(mile)
○ Tire circumference	Setting range : 50 ~ 210 % Setting unit : 1 %
○ Trip meter A、B	Display range : 0 ~ 9,999.9 km (mile) Display unit : 0.1 km (mile)
○ Mileage maintenance	Setting range : off、500 ~ 16,000 km (300 ~ 10,000 mile)~ -999 km (mile), decrease according to the increase in total mileage. Setting unit : 1 km (mile)
● Gear meter	Display range : off、N、P、R、1、2、3、4、5、6
● Tachometer	Display range : 0 ~ 9,990 RPM Display unit : 10 RPM
○ RPM shift light	Display range : 2,000 ~ 8,000 RPM Warning lights on when exceed setting value (including). Setting unit : 100 RPM
○ Max. rotating speed	Display range : 0 ~ 8,000 RPM Display unit : 100 RPM
● Engine temperature	Setting range : -40 ~ 300 °C (-40 ~ 572 °F)
● Fuel meter	Setting range : HD Std / Cust
○ Fuel warning setting	Setting range : 1. HD Standard - LCD flashing as warning when Fuel level resistance greater than 211Ω, and will turn off when resistance smaller than 187Ω. 2. Customize - LCD flashing as warning when Fuel level lower than 20%, and will turn off when fuel level higher than 30%.

Item number  
Backlight color Display range Casing



\* B A 0 6 4 9 1 1 \*  
Blue 0~299 km/h Black

\* B A 0 6 4 9 2 1 \*  
Red 0~299 km/h Black

## HD-06 Harley Touring LED Instrument Kit for 2014+

Our plug & play multifunction speedometer & tachometer kit is equipped with adjustable brightness LED display. These meters provide the basic function of speed, RPM, gear position, odometer and trip meter. They also include a clock and all the necessary indicator lights and are easy to connect and install. These meters are a great addition to all Harley-Davidson® FLHX, FLTC and FLTR from 2014 to 2017.

○ Fuel tank volume	Setting range : OFF / 1.0 ~ 9.9 US gallons	
○ Average fuel consumption	Setting range : OFF / L/100km · km/L · MPG (US spec.) · MPG(UK spec.)	
● RANGE / Remaining Mileage	Display range : 0 ~ 9,999 km (6,249 miles) Display unit : 1 km (mile)	
○ RANGE / Remaining Mileage Warning	Display range : LCD shows "LO RING" and flashing as warning when RANGE / Remaining Mileage lower than 16 km (10 miles).	
● Clock	Setting range : 12 / 24 hour format	
● Oil Temp.	Display range : 0 ~ 400 °F [ 32 ~ 248 °C] Display unit : 1 °C (°F)	
○ Max. Oil Temp. record	Display range : 0 ~ 400 °F [ 32 ~ 248 °C]	
● Air Pressure Gauge	Display range : Display --- when no sensor is installed, 0 ~ 150 PSI Display unit : 1 PSI	
● Air Pressure Gauge Calibration	Calibration range : 0 ~ 25 PSI±1PSI Calibration unit : 1 PSI Default value : 0 PSI	
● Backlight brightness	Setting range : 1 / 5 (darkest) ~ 5 / 5 (brightest)	
● Operating voltage	DC 12 V	
● Temperature range	-10 ~ +60 °C	
● Specifications	JIS D 0203 (S2)	
● Meter Weight - Speedo & Tacho	286 grams	
● Meter Weight - Oil Temp.	81 grams	
● Meter Weight - Fuel Level	81 grams	
● Indicators		
Turn signal (Green)	↔ Water temperature (Blue)	↕
Photometric Sensing	Warning Light (Orange/Green)	⚠
Oil (Red)	High beam (Blue)	⚡
Engine warning (Yellow)	Fog Light (Green)	🌫
Constant speed (Orange / Green)	ABS (Yellow)	ABS
Security (Red)	Turn signal (Green)	↔

Plug & play

# Harley-Davidson D2



NEW!



●Speedometer	Display range : 0~199 km (0~124 mile) switchable Display unit : 1 km (mile)
○Display interval	<0.5 second
○Internal and external odometer	Display range : 000,000~999,999 km (mile) returns to zero upon exceeding Display unit : 1 km (mile)
○Trip meter A,B	Display range : 0,000.0~9,999.9 km (mile) returns to zero upon exceeding Display unit : 0.1 km (mile)
○Tire circumference	Setting range : 50 ~ 210 % Setting unit : 1 %
●Tachometer	Display range : 0 ~ 10,000 RPM
○Shift light warning	Setting range : 2,000 ~ 10,000 RPM When it is higher than the setting value (including), the backlight will blink in red and white as a warning. Setting unit : 100 RPM
●Engine temperature	Setting range : -39 ~ 300 °C (-38 ~ 572 °F)
●Clock	Setting range : 12   24 hour format
●Voltmeter	Display range : 8 ~ 18 V
●Backlight brightness	Setting range : 1 /5(darkest)~ 5 / 5(brightest)
○Backlight color	Setting range : white, red, orange, yellow, green, blue, light blue, purple
●Mileage maintenance	Setting range : Off, 500 ~ 16,000 km(300 ~ 10,000 mile) Setting unit : 100 km (miles)
●Tire pressure	<b>(TPMS, FR/RR/LR shall be displayed when the vehicle supports TPMS)</b> Display range : ---, Hi, 0~73 PSI, 0~506 kPa, 0.0~5.0 bar Display unit : 1 PSI, 1 kPa, 0.1 bar
●Fuel meter	Display range : 10 levels
●Operating voltage	DC 12 V
●Operating temperature	-20~85 °C
○Storage temperature	-30~90 °C
●Specifications	JIS D 0203 (S2)
●Meter size	88.2 x 67.0 x 35.2 mm
●Meter weight	Around 70 g
●Indication light	Right indication light (Green) Security light (Red) ABS light (Amber) Motor oil light (Red) Neutral light (Green) High beam light (Blue) Low fuel warning light (Amber) Left indication light (Green) Fog light (Green) Battery discharge light (Red) Engine light (Amber) Cruise light (Green/Amber) Tire pressure warning light (Amber)



## D2 | multifunction meter For 2018-2022 Street Bob

You can now customize your Street Bob with our new high quality 100% plug & play meter that is equipped with an 8-color changeable LCD display. This gauge features a tach and speedo combo with a programmable shift light and includes a gear indicator for easily seeing what gear you're in.

This gauge also features vital readings such as engine temperature, battery voltage, tire pressure and a complete system of indicator lights to monitor your bikes vital signs. This gauge will fit directly into the stock harness and works directly with your bikes CANBUS system.

Item number  
Display Models



\* B A 0 8 0 0 0 0 \*  
Negative 18"-22"

## Plug & play

### D2 | multifunction meter For DYNA / SOFTTAIL / 883

Whether you have a Dyna, Softail, Sportster or Roadking model, this new D2 plug and play multifunction meter will provide you vital readings such as engine temperature, battery voltage, tire pressure and a complete system of indicator lights to monitor your bike's vital signs. This gauge will fit directly into the stock harness and work with your bike's CANBUS system.

It also features a tach and speedo combo with a programmable shift light, a gear indicator for easily seeing what gear you're in and an 8-color changeable LCD display.



020 / 021

NEW!



- Speedometer Display range : 0~199 km (0~124 mile) switchable  
Display unit : 1 km (mile)
- Internal and external odometer Display range : 000,000~999,999 km (mile)  
returns to zero upon exceeding  
Display unit : 1 km (mile)
- Trip meter A,B Display range : 0,000.0~9,999.9 km (mile)  
returns to zero upon exceeding  
Display unit : 0.1 km (mile)
- Tire circumference Setting range : 50 ~ 210 %  
Setting unit : 1 %
- Tachometer Display range : 0 ~ 10,000 RPM
- Shift light warning Setting range : 2,000 ~ 10,000 RPM  
When it is higher than the setting value (including),  
the backlight will blink in red and white as a warning.  
Setting unit : 100 RPM
- Engine temperature Setting range : -40 ~ 300 °C (-40 ~ 572 °F)
- Fuel meter Setting range : OFF, Sportster fuel volume switch  
original fuel kit (PN 6120008A),  
Dyna, CUST (User define)
- Fuel tank volume Setting range : OFF/ 1.0 ~ 9.9 US gallons
- Average fuel consumption Display range : OFF, L/100km, km/L, MPG (US spec.),  
MPG (UK spec)

Item number  
Display Models



\*BA080010\* Negative 04~13'  
\*BA080020\* Negative 14~

NEW!



- Speedometer Display range : 0~199 km (0~124 mile) switchable  
Display unit : 1 km (mile)
- Internal and external odometer Display range : 000,000~999,999 km (mile)  
returns to zero upon exceeding  
Display unit : 1 km (mile)
- Trip meter A,B Display range : 0,000.0~9,999.9 km (mile)  
returns to zero upon exceeding  
Display unit : 0.1 km (mile)
- Tire circumference Setting range : 50 ~ 210 %  
Setting unit : 1 %
- Tachometer Display range : 0 ~ 10,000 RPM
- Shift light warning Setting range : 2,000 ~ 10,000 RPM  
When it is higher than the setting value (including),  
the backlight will blink in red and white as a warning.  
Setting unit : 100 RPM
- Engine temperature Setting range : -40 ~ 300 °C (-40 ~ 572 °F)
- Fuel meter Setting range : 10 levels
- Fuel tank volume Setting range : OFF/ 1.0 ~ 9.9 US gallons
- Average fuel consumption Display range : OFF, L/100km, km/L, MPG (US spec.),  
MPG (UK spec)
- Air Pressure Gauge Display range : Display --- when no sensor is installed,  
0 ~ 150 PSI, 0~1034 kPa, 0.0~10.3 bar  
Display unit : 1 PSI, 1 kPa, 0.1 bar

Item number  
Display Models



\*BA080030\* Negative 14~

### D2 | multifunction meter For Bagger 2014+

D2 plug and play multifunction meter will provide you vital readings such as engine temperature, battery voltage, tire pressure and a complete system of indicator lights to monitor your bike's vital signs. This gauge will fit directly into the stock harness and work with your bike's CANBUS system.

It also features a tach and speedo combo with a programmable shift light, a gear indicator for easily seeing what gear you're in and an 8-color changeable LCD display.



Plug & play 2024

## Plug & play

### DL-04 Harley Sportster Meter For 04'-13' / 2014+ Meter

The all-new 100% plug and play DL-04 for 4 1/2" gas tank mounted Harley-Davidson models features a tach and speedo combo with a programmable shift light with gear indicator. This gauge also features vital readings such as engine temperature and battery voltage along with average fuel economy and a complete system of indicators to monitor your bikes vital signs.



NEW!

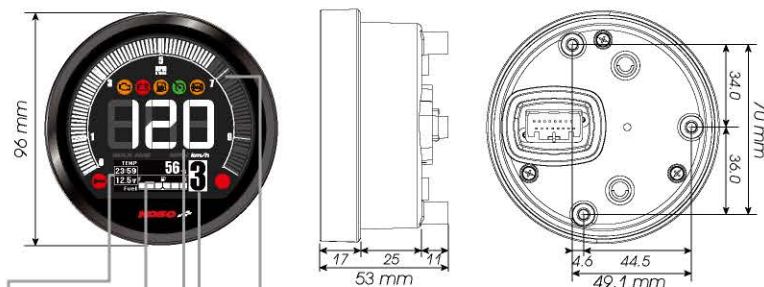

#### Speedometer

- Display range : 0 ~ 360 km/h (0 ~ 225 MPH)
- Display unit : 1 km/h (MPH)

#### Temperature

- Display range : -40~300 °C (-40~572 °F)
- Display unit : 1 °C (°F)

#### Fuel Meter

- Display range : 6 levels
- Setting Range : OFF, Dyna, Dyna-04, Dyna-09, Customer

#### Clock

- Setting range : 00:00~23:59 (24H)
- 01:00~12:59 (12H)

#### Voltmeter

- Display range : DC 8.0 ~ 18.0 V
- Display unit : DC 0.1 V

#### Tachometer

- Display range : 0~10,000 RPM
- Display unit : 111 RPM

#### Gear Meter

- Display range : OFF, highest gear, N and highest gear, show all (N / 1 ~ 6)

Item number  
Display Models



\* BA 0 7 7 4 0 0 \*

Negative 04'-13'

\* BA 0 7 7 4 1 0 \*

Negative 2014+

Fits XL-883 & XL-1200

2004 to 2013 & Dyna 2004-2011

Fits XL-883 & XL-1200

2014+, Softail 2011+ & Dyna 2012+

● Speedometer	Display range : 0 ~ 360 km/h (0 ~ 225 MPH) switchable Display unit : 1 km/h (MPH)
○ Display interval	<0.5 second
○ Internal and external odometer	Display range : 0 ~ 99,999 km (miles) return to zero upon exceeding Display unit : 1 km (mile)
○ Trip meter A,B	Display range : 0 ~ 9,999.9 km (miles) returns to zero upon exceeding Display unit : 0.1 km (mile)
○ Tire circumference	Setting range : 50 ~ 210 % Setting unit : 1 %
● Gear meter	Display range : off, highest gear, N and highest gear, show all (N / 1 ~ 6)
● Tachometer	Display Range : 0 ~ 10,000 RPM
○ RPM shift light	Setting range : 2,000 ~ 10,000 RPM Warning lights on when exceed setting value (including). Setting unit : 100 RPM
○ Max. RPM warning mode	Setting range : F-OFF (Lit.), F-ON (blink)
● Engine temperature	Setting range : -40 ~ 300 °C (-40 ~ 572 °F)
● Fuel meter	Display range : 6 levels Setting range : OFF, Dyna, Dyna-04, Dyna-09, Customer
○ Fuel tank volume	Setting range : OFF/ 1.0 ~ 17.9 US gallons
○ Average fuel consumption	Display range : OFF \ L/100 km \ km/L \ MPG (US spec.) \ MPG (UK spec)
● Clock	Setting range : 12 / 24 hour format
● Voltmeter	Display range : 8 ~ 18 V
● Backlight brightness	Setting range : 1 / 5 (darkest) ~ 5 / 5 (brightest)
● Mileage maintenance	Setting range : Off, 500 ~ 16,000 km (300 ~ 10,000 mile) Setting unit : 100 km (miles)
● Operating voltage	DC 12 V
● Operating temperature	-20 ~ +85 °C
● Specifications	JIS D 0203 (S2)
● Meter size	D 96 mm
● Meter weight	About 184 g
● Indication light	RPM shift light (Red light) ● Low fuel warning light (Amber light) ⚡ Engine check light (Amber light) ⚙️ Battery discharge light (Red light) 🔋 Security light (Red light) 🔑 Cruise light (Amber / Green light) 🏠 ABS light (Amber light) 🛑

Plug & play

# Harley-Davidson Oil Dipstick

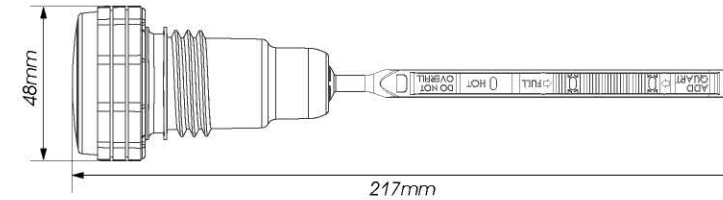
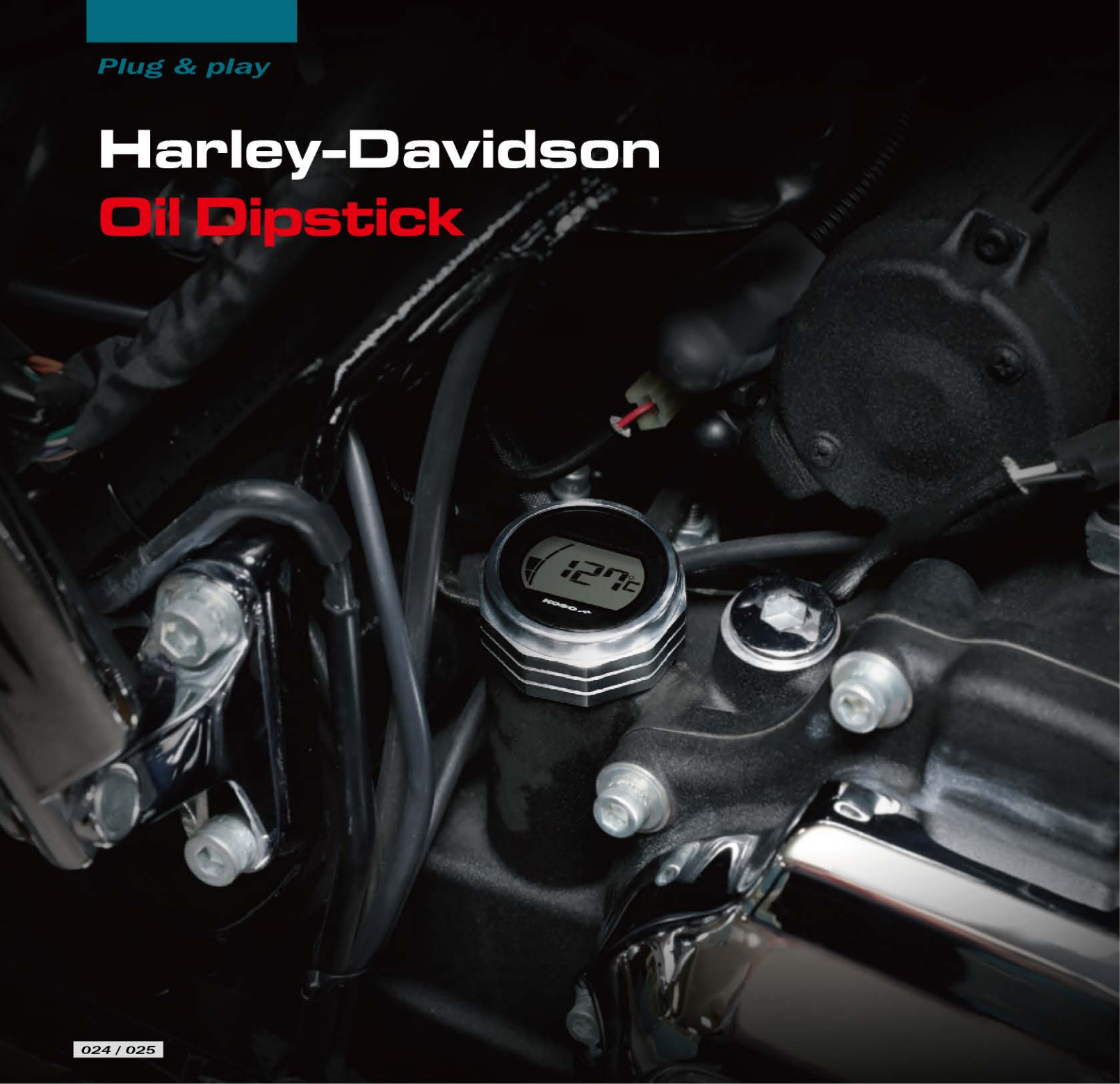

- Thermometer Display range : 0~150°C (32~302°F)  
Display Unit: 1°C(°F)
- Fuel meter Display range: 1~4 level
- Low battery warning When low battery warning appears, battery replacement is needed to keep the dipstick accurate.
- Battery specification CR2032
- Meter working temperature -10~60°C
- Meter standard JIS D 0203(S2)
- Meter size 21.7x48 mm
- Meter weight About 273 g



Display	Item number	Touring models	Casing
Positive	* B A 0 5 3 0 0 1 *	07-16'	Black
Negative	* B A 0 5 3 0 0 0 *	07-16'	Black
Positive	* B A 0 5 3 0 1 1 *	07-16'	Silver
Negative	* B A 0 5 3 0 1 0 *	07-16'	Silver

Positive	* B A 0 5 3 1 0 1 *	2017+	Black
Negative	* B A 0 5 3 1 0 0 *	2017+	Black
Positive	* B A 0 5 3 1 1 0 *	2017+	Silver
Negative	* B A 0 5 3 1 1 1 *	2017+	Silver

## Oil Dipstick

The Harley Davidson Oil dipstick by Koso is a fast and simple solution to verifying oil level as well as temperature. The push to power technology provides the ability to check your bike's oil vital signs on the go or at a red light with ease.

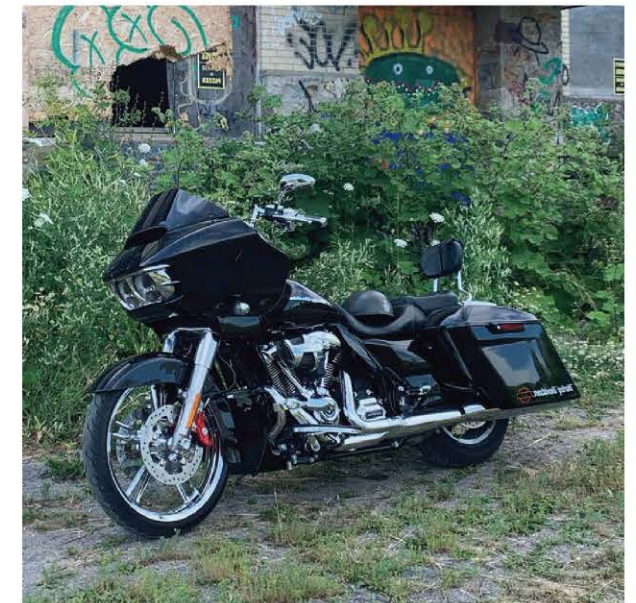

### KOSO Yamaha BOLT Meter

Plug & Play meter for YAMAHA BOLT 950, fully equipped with all function you need. Such as tachometer, speedometer, odometer, trip meter, shift light, fuel level, indicator lights and so on. Special design with 7 color changeable display to allow you customize your favor backlight color during your riding to maximize the fun!

This meter suitable for YAMAHA BOLT both R-spec and C-spec up to year 2016 models.



- Indicator
- Round
  - High beam
  - Engine Check
  - Turn signal
  - Immobilizer system
  - Oil
  - ABS

**Speedometer**

- Speedometer : 0~360 km (0~225 mile)
- Display unit : 1 km (mile)

**Motor oil maintenance millage**

- Display range : User settings (500 ~ 16000km / 300 ~ 10000 mile) ~ -999 km (mile) : decrease according to the increase in total millage.
- Display unit : 1 km(mile)

**Clock**

- Display range : 12 / 24hour forment

**Engine temp.**

- Display range : -30 ~ 225 °C (-22 ~ 437 °F)

**Max. RPM**

- Display range : 0 ~ 8,000 RPM
- Display unit : 100 RPM

**Max. temperature record**

- Display range : -30 ~ 225 °C (-22 ~ 437 °F)
- Display unit : 0.1 km (mile)

**Max gear level record**

- Display range : - (No display), N, 1 ~ 5 gear level
- Record gear level when at maximum rpm.

**Odometer**

- Display range : 000000 ~ 999999 km (mile)
- returns to zero upon exceed
- Setting unit : 1 km (mile)

**Trip meter A、B**

- Display range : 0000.0 ~ 9999.9 km (mile)
- returns to zero upon exceed
- Setting unit : 0.1 km (mile)

**fuel reserve tripmeter(TRIP-F)**

- Display range : 0000.0 ~ 9999.9 km (mile)
- returns to zero upon exceed
- Display unit : 0.1 km (mile)

Item number	Display	Display range	Casing
-------------	---------	---------------	--------



★BA051300★  
Negative 0~360 km/h Chrome



★BA051301★  
Positive 0~360 km/h Chrome



★BA051310★  
Negative 0~360 km/h Black



★BA051311★  
Positive 0~360 km/h Black



- Speedometer Display range : 0 ~ 360 km (0 ~ 225 mile)  
Display unit : 1 km(mile)
- Overspeed warning setting Setting range : 30 ~ 360 km (19 ~ 225 mile) when above (including) setting value,warning light will lit.
- Max. speed record Display range : 0 ~ 360 km (0 ~ 225mile)  
Display range : 0 ~ 999,999 km(mile)
- Speedometer Display range : 0 ~ 360 km (0 ~ 225 mile)  
Display unit : 1 km(mile)
- Trip meterA、B Display range : 0 ~ 9,999.9 km(mile)
- Motor oil maintenance Setting range : close、500 ~ 16,000 km (300 ~ 10,000 mile)
- fuel reserve tripmeter Display range : 0 ~ 9999.9km(mile)
- Tire percentage Setting range : 50 ~ 200 %
- Gear meter Display range : - (No display), N, 1 ~ 5 gear level
- Display interval Display range : < 0.5 sec
- Max. gear level record Display range : - (No display), N, 1 ~ 5 gear level  
Record gear level when at maximum rpm
- RPM Display range : 0 ~ 8,000 RPM
- Shift light warning setting Setting range : 1,000 ~ 8,000 RPM when above (including) setting value,warning light will lit.
- Digital tachometer Display range : 0 ~ 8,000 RPM
- ABS indicator setting Setting range : Close(OFF) - Open(ON)
- Thermometer Display unit : °C, °F, switchable
- Water temperature meter Display range : -30 ~ 225 °C (-22 ~ 437 °F)
- Overheat warning setting Setting range : 60 ~ 225 °C (140 ~ 437 °F) when above(including) setting value,warning light will lit.
- Max. temperature record Display range : -30 ~ 225 °C (-22 ~ 437 °F)
- Round indicator speeding warning ligh,RPM shift light,over heat warning light,Low volt warning,Fuel warning,oil maintenance,Highest gear
- Warning cause Lit.(L),Slow flash(S),Flash(F)
- Warning method Lit.(L),Slow flash(S),Flash(F)
- Fuel meter Display range : (ON) - (OFF) - Flash
- Clock Setting range : 12 / 24 hour forment
- Under voltage warning Setting range : 8.0 ~ 18.0 V
- Back light brightness Setting range : 1 - 5(darkest)~ 5 - 5(brightest)
- Back light color Setting range : red, orange, yellow, green, blue, light blue, purple, white, loop switch
- Operating voltage DC 12 V
- Operating temperature -10 + 60 °C
- Specification JIS D 0203 S2
- Meter Size 94.7 x 94.7 x 69.2 mm
- Meter Weight Around 217 g
- Indicator Round (red light), High beam (blue light), Engine Check (yellow light),Turn signal (green light), Immobilizer system Indicator light (red light), Oil (red light), ABS (yellow light)



## Plug & play

E-mark approval

### DL-04 For Yamaha BOLT

With its classical round shape, Koso's newest addition to the DL-04 series is the perfect plug and play speedometer for Yamaha Bolt®.

Its innovative negative LCD screen features a variety of functions such as a gear indicator, 6 indicator lights, tachometer, voltage, clock and much more.



NEW!

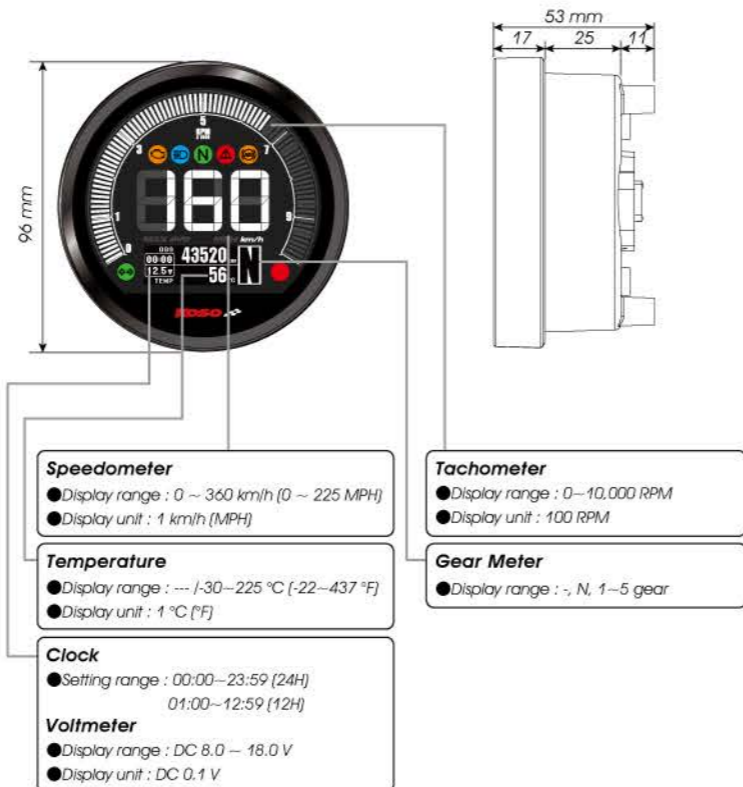

Item number



● Speedometer	Display range : 0 ~ 360 km/h (0 ~ 225 MPH) Display unit : 1 km/h (MPH) Switchable
○ Speeding warning setting	Setting range : 30~360 km/h (19~225 MPH). When exceeding the set value (inclusive), the value flickers and the warning signal will be lit according to the setting. Setting unit : 1 km/h (MPH)
○ Max. speed record	Display range : 0 ~ 360 km/h (0 ~ 225 MPH), can return to zero manually Display unit : 1 km/h (MPH)
○ Odometer	Setting range : 0 ~ 99,999 km (mile) Setting unit : 1 km (mile)
○ Trip meter A, B	Display range : 0.0~9,999.9 km (mile), can return to zero manually Display unit : 0.1 km (mile)
● Motor oil maintenance (Trip O)	Display range : OFF, -999~16,000 km (-999~10,000 mile), can be reset manually Display unit : 1 km (mile)
○ Motor oil maintenance warning	Setting range : OFF, 500 ~ 16,000 km (300~10,000 mile) When lower than 0 km (mile), the value shows on the screen and flickers for warning, and the warning signal will be lit according to the setting. Setting unit : 100 km (mile)
● Trip F	Display range : 0.0~9,999.9 km (mile), can be reset manually Display unit : 0.1 km (mile)
● Tire percentage	Setting range : 50~200 % Setting unit : 1 %
● Gear Meter	Display range : -, N, 1~5 gear
○ Max. Gear record	Display range : -, N, 1~5 gear, can return to zero manually
● Tachometer	Display range : 0~10,000 RPM Display unit : 1,000 RPM (Large grid) / 111 RPM (Small grid)

○ Shift light warning	Setting range : 1,000~10,000 RPM, When exceeding the set value (inclusive), the warning signal will be lit according to the setting. Setting unit : 100 RPM
○ Max. RPM record	Display range : 0~10,000 RPM, can return to zero manually Display unit : 100 RPM
● Temperature	Display range : --- /-30~225 °C (-22~437 °F) Display unit : 1 °C (°F)
○ Overheat warning setting	Setting range : 60~225 °C (140~437 °F), When exceeding the set warning value, the value flickers, and the warning signal will be lit according to the setting. Setting unit : 1 °C (°F)
○ Max. temperature record	Display range : -30~225 °C (-22~437 °F), can return to zero manually Display unit : 1 °C (°F)
● Fuel meter	Display range : ON, OFF, unusual warning
● Clock	Setting range : 00:00~23:59 (24H) 01:00~12:59 (12H)
● Voltmeter	Display range : DC 8.0 ~ 18.0 V Display unit : DC 0.1 V
○ Low voltage warning	Setting range : DC 8.0~13.0 V, When lower than the set warning value for over five seconds, the value flickers, and the warning signal will be lit according to the setting. Setting unit : DC 0.1 V
● Backlight brightness	Setting range : 1/5 (darkest)~ 5/5 (brightest) Setting unit : 1/5 (20%)
● Indicator	Check engine light (Amber)  High beam light (Blue)  Neutral light (Green)  Warning light (Red)  ABS light (Amber)  Turn signal light (Green)  Anti-theft light (Red) 





# Plug & play

E-mark approval

## RX4 For Yamaha MT Series

\*An additional bracket is required to make it fit in the original location for the MT-09 / XSR 700 / XSR 900.

With its modern look and features, this RX-4 speedometer is the perfect plug and play meter for the MT-07/MT-09 or the XSR 700 / XSR900 models.

Featuring speed, odometer, tripmeter, hour meter, voltage, clock and stopwatch as well as 6 indicator lights, this meter will provide you all the data you need.



NEW!



**Speedometer**  
 ● Display range : 0 ~ 360 km/h (0 ~ 225 MPH)  
 ● Display unit : 1 km/h (MPH)

**Tachometer**  
 ● Display range :  
 MT-07 : 0 ~ 12,000 RPM  
 MT-09 : 0 ~ 13,000 RPM  
 XSR700 : 0 ~ 12,000 RPM  
 XSR900 : 0 ~ 13,000 RPM

**Fuel meter**  
 ● Display range : 6 levels  
 ● Display unit : 1 level (16.6%)  
**Fuel warning**  
 ● Display range : The warning value for low fuel shall be 1 segment and below, the warning signal will blink.

**Gear Meter**  
 ● Display range : -, N, 1 - 6

Item number	Item number	Item number
Backlight color	Backlight color	Backlight color
		
4color	4color	4color
* B A 0 8 1 0 0 0 * MT 07 (2014~2020) MT 09 (2014~2016) XRS 700 (2015~2021) XRS 900 (2016~2021)	* B A 0 8 1 0 0 1 * MT 09 (2017~2020)	* B A 0 8 1 1 0 0 * MT 07 (2021~)

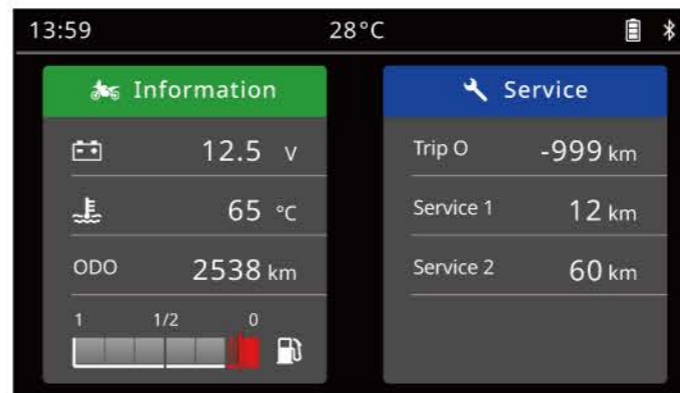

● The Vehicle condition screen.

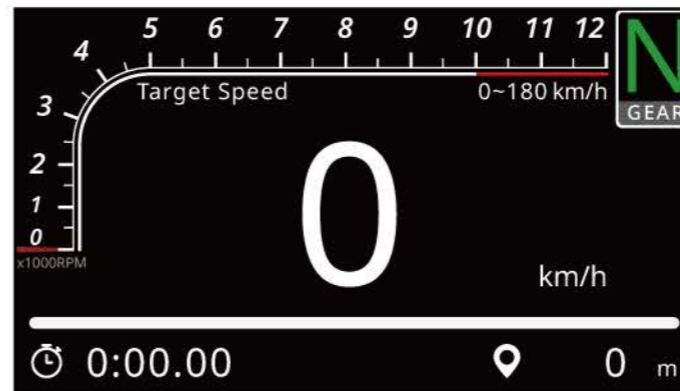

● The testing screen.



● The setting screen.



# Plug & play

E-mark approval

## DL-04 For BMW R nineT®

With its modern look, this DL-04 speedometer is the perfect plug and play meter for the BMW R nineT bikes.

Featuring speed, odometer, tripmeter, hour meter, voltage, clock and stopwatch as well as 6 indicator lights, this meter will give you all information you need.



NEW!



- Speedometer**
  - Display range : [2013-2016] 0 ~ 360 km/h [2017-2021] 0 ~ 220 km/h
  - Display unit : 1 km/h
- Temperature**
  - Display range : [2013-2016] 8.0 ~ 18.0 V [2017-2021] 10.0 ~ 16.0 V
- Clock**
  - Setting range : [2013-2016] 12h / 24 h [2017-2021] 24 h
- Voltmeter**
  - Display range : [2013-2016] 8.0 ~ 18.0 V [2017-2021] 10.0 ~ 16.0 V
- Tachometer**
  - Display range : [2013-2016] 0 ~ 10,000 RPM / 0 ~ 15,000 RPM [2017-2021] 0 ~ 10,000 RPM
- Gear Meter**
  - Display range : N, 1 ~ 6

Item number	LCD	Models	Bezel
-------------	-----	--------	-------



\* B A 0 7 7 1 0 1 \*

Negative 2014-2016 Black

- Speedometer [2013-2016] Display range : 0 ~ 360 km/h [2017-2021] Display range : 0 ~ 220 km/h Display unit : 1 km/h
- Internal and external odometer Display range : 0 ~ 99,999 km Display unit : 1 km (mile)
- Trip meter 1 & 2 Display range : 0 ~ 9,999.9 km Display unit : 0.1 km
- Trip meter A Daily riding mileage Display range : 0 ~ 9,999.9 km Display unit : 0.1 km
- Gear Display range : N ~ 1 ~ 6
- Tachometer [2013-2016] Display range : 0 ~ 10,000 RPM / 0 ~ 15,000 RPM [2017-2021] Display range : 0 ~ 10,000 RPM
- Clock [2013-2016] Setting range : 12h / 24 h [2017-2021] Setting range : 24 h
- Temperature Display range : 0 ~ 250°C
- Voltage [2013-2016] Display range : 8.0 ~ 18.0 V [2017-2021] Display range : 10.0 ~ 16.0 V
- Backlight brightness Setting range : 1 - 5 (darkest) ~ 5 - 5 (brightest)
- Operating voltage DC 12V
- Temperature range -10 ~ +60°C
- Specifications JIS D 0203(S2)
- Meter Size D 96 mm
- Indication light
  - Engine warning light (Amber)
  - High beam light (Blue)
  - Neutra light (Green)
  - Warning light (Red)
  - ABS light (Amber)
  - Trun signal light (Green)
  - [2013-2016] ASC / DWA Warning light (Red)
  - [2017-2021] RPM shift light (Red)

Item number	LCD	Models	Bezel
-------------	-----	--------	-------



\* B A 0 7 7 0 0 1 \*

Negative 2017-2020 Black

Negative 2021~ Black



# Plug & play

E-mark approval

## RX5 For BMW R1200GS® 2013-2017

New generation meter – RX5 equip with colorful 5" TFT LCD display, Bluetooth® connectivity and extremely user friendly interface to maximize the fun you will have during the riding. The RX5 meter is designated to BMW R1200 GS from model year 2013 to 2017 plug & play. If you have this bike and want to have a new TFT meter like brand new GS model, then this is it --- your best choice!

The Bluetooth® connectivity allow you to enjoy the music streaming through your headset or hands-free and shows the name of the song that you currently listening to, not to mention the incoming call number/contact name display and the navigation directly notification. All those are included in this fantastic instrument, and wait for you to explore.



NEW!



### Digital ENG Thermometer

- Display range : 0.0~250.0°C (32.0~482°F)
- Display unit : 0.1 °C (°F)

### Voltmeter

- Display range : DC 8.0~18.0 V
- Display unit : DC 0.1 V

### Fuel meter

- Display range : 6 level
- Display unit : 16.6 % each segment

### Gear meter

- Display type : Off, Rotary Shift, Return Shift Learn
- Display range : N, 1~9

### Speedometer

- Display range : 0 ~ 360 km/h (0 ~ 223 MPH)
- Display unit : km/h, MPH

### Tachometer

- Display range : 0~10,000 RPM
- Display unit : 100 RPM

Item number  
Model



K Link  
for iOS & Android



● Main screen.



● Price of oil.



● Navigation.



● Maintenance.



● Connect.



Scan the QR code to connect the video



## Plug & play

### RX6 For TRIUMPH TRIDENT

New generation meter – RX6, Bluetooth® connectivity and extremely user friendly interface to maximize the fun you will have during the riding. The RX6 meter is designated to Triumph Trident plug & play. The Bluetooth® connectivity allow you to enjoy the music streaming through your headset and shows the name of the song that you currently listening to, not to mention the incoming call number/contact name display and the navigation directly notification. All those are included in this fantastic instrument, and wait for you to explore.



036 / 037

NEW!



#### Gear meter

- Display range : N, 1~6

#### Coolant Temperature

- Display range : 0~250°C (32~482°F)
- Display unit : 1 °C (°F)

#### Fuel meter

- Display range : 8 levels
- Display unit : 12.5 % each segment

#### Tachometer







- Display range : 0~11,000 RPM
- Display unit : 100 RPM

#### Speedometer

- Display range : 0 ~ 360 km/h (0 ~ 225 MPH)
- Display unit : km/h, MPH

Item number  
Model



● Speedometer	Display range : 0 ~ 360 km/h Display unit : 1 km/h	
● Average Speed 1、2	Display range : 0 ~ 360.0 km/h Display unit : 0.1 km/h	
● Time Meter 1、2	Display range : 0 ~ 99.99 hr Display unit : 0.01 hr	
○ Odometer	Display range : 0 ~ 99,999 km Display unit : 1 km (mile)	
● Trip Meter 1、2	Display range : 0 ~ 9,999.9 km Display unit : 0.1 km	
● Service	Display range : 0~0,000,000 km	
● Gear	Display range : N、1 ~ 6	
● Tachometer	Display range : 0 ~ 11,000 RPM	
● Riding Mode	Display range : Road、Rain、Sport	
● Traction Control	Setting range : Enable、Disable	
● Coolant Temperature	Display range : 0 ~ 250°C	
● Fuel Meter	Display range : 8 levels	
● Fuel Consumption	Display range : 0~99.9 km/L(MPG、L/100km)	
● Fuel Range Meter	Display range : 0~999 km (mile)	
● Average Fuel Meter	Display range : 0~999.9 km/L(MPG、L/100km)	
● TPMS	Display range : 0.0~3.5 bar(1~50 psi、7~344kPa) Display unit : 0.1 bar(1 psi、1kPa)	
● Clock	Setting range : 12、24H Setting range : 00:00~23:59、01:00 ~ 12:59	
● Navigation	Display range : Turning precaution、Estimated turning distance、Speed Camera、Speed Limit	
● Incoming phone call notice	Display range : Contact Name、Contact Number、Phone book	
● Music	Display range : Song title、Artist name	
● SMS	Display range : Contact Name、Content	
● Background Display	Setting range : AUTO(Optical Sensing)、Positive、Negative	
● Backlight brightness	Setting range : 1 - 5 (darkest) ~ 5 - 5 (brightest)	
○ Operating voltage	DC 12V	
● Temperature range	-10 ~ +60°C	
○ Specifications	JIS D 0203(S2)	
● Meter Size	D 117.6 X 151.5 X 48.5 mm	
● Indication light	Trun signal light (Green)  High beam light (Blue)  Engine warning light(Amber)  Traction Control(Amber)  IMMO(Red)  ABS light (Amber)  Neutra light (Green) 	

RX1N+

Just the right size & shape designed for ATV & Motorcycle. With the up to 15,000 RPM tachometer & the illuminated needle, you could read the information easily even in the night.

With the MAX power test, you could check the top speed your machine could reach and the time & distance you need to reach it.

The target distance test provides you the chance to see how fast you are and how much time you need to reach at a limited distance.

The target speed test provides you the information of how much distance you need to reach the speed you set and how long it takes.

It is just like you have a DYNO on your machine for you to adjust your machine. Are you ready to join the race?



**The RPM Red, Yellow shift light**  
 ●Setting range: 1,000~15,000 RPM.  
 ●Setting unit: 100 RPM.  
 ●Warning: on (F-OFF), Flash (F-ON)

**Temperature warning (water & oil temperature)**  
 ●Setting range: 60~120°C (140~248°F).  
 ●Setting unit: 1°C (°F).



Target Speed test



Target distance test



MAX record

Item number  
 Backlight color Display range Panel color



\*BA011200\* White 0~15,000 RPM Black  
 \*BA011210\* Blue 0~15,000 RPM Black  
 \*BA011220\* Blue 0~15,000 RPM White

Option accessory

<p><b>1</b> Disc magnet screw</p>	<p><b>2</b> Active speed sensor</p>	<p><b>3</b> Digital speed signal sensor</p>	<p><b>4</b> Digital speed signal sensor</p>
<p><b>5</b> Digital speed signal sensor</p>	<p><b>6</b> Digital speed signal sensor</p>	<p><b>7</b> L type speed sensor bracket</p>	<p><b>8</b> Temp sensor wire set (2.4M)</p>
<p><b>9</b> Oil temp sensor adapter</p>	<p><b>10</b> Water temp sensor adapter</p>	<p><b>11</b> Temp sensor</p>	<p><b>12</b> Cylinder head temp sensor</p>



RX2+

The RX-2 is probably one of our best seller. Its unique changeable backlight colors make's it a very popular instrument. The illuminated needle with LED pointer make's the RX-2 a very easy gauge to read even at night. This instrument features many different functions such as speed, odometer, tripmeter, RPM, shift light, temperature, indicator lights and many other cool functions. Set yourself apart with the RX-2!



**The RPM Red, Yellow shift light**  
 ●Setting range: 1,000~15,000 RPM  
 ●Setting unit: 100 RPM  
 ●Warning: on (F-OFF), Flash (F-ON)

**The top RPM recall indicator light**  
 ●The indicator light will move according to the current RPM.  
 ●The top RPM indicator light will show you top top RPM you reach and light on for 3 seconds.



Target speed test



Target distance test



MAX record

Item number  
 Backlight color Display range Panel color



\*BA010100\* Blue 0~15,000 RPM Black

Option accessory

<p>Kawasaki NINJA 250R              Model RX2</p>	<p>Plug &amp; Play Kit              Kawasaki NINJA 250R              Model RX2</p>	<p>Plug &amp; Play Kit              Kawasaki NINJA 250R(FI)              Model RX2</p>
-------------------------------------------------------	--------------------------------------------------------------------------------------------	------------------------------------------------------------------------------------------------



RX2N+

The RX-2N has been developed with the best components and latest technology on the market. The illuminated needle with LED pointer make's the RX-2N a very easy gauge to read even at night. This instrument features many different functions such as speed, odometer, tripmeter, RPM, shift light, temperature, indicator lights and many other cool functions. The 10 000 rpm and 20 000 rpm version gives the opportunity to better choose the right RPM scale for your bike.

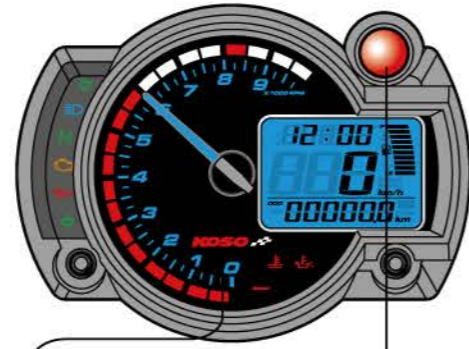

**Tachometer warning light**  
 ● Setting range: 5,000~10,000 RPM.  
 ( 5,000~20,000 RPM)  
 ● Setting unit: 100 RPM.

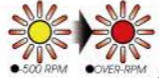

**The top RPM recall indicator light**  
 ● The indicator light will move according to the current RPM.  
 ● The top RPM indicator light will show you top top RPM you reach and light on for 3 seconds.



Target speed test



Target distance test



MAX record

Item number  
 Backlight color Display range Panel color



\* BA015B15\*  
 Blue 0~10,000 RPM Black



\* BA015B16\*  
 Blue 0~10,000 RPM White



\* BA015B25\*  
 Blue 0~20,000 RPM Black



\* BA015B27\*  
 Blue 0~20,000 RPM White



\* BA015100\*  
 8 color 0~20,000 RPM Black



\* BA015200\*  
 8 color 0~10,000 RPM Black

● Speedometer	Display range: 0~360 km/h (0~225 MPH) Display unit: km/h & MPH for alternative												
○ Display internal	<0.5 second												
○ Odometer	Display range: 0~99999.9 km (mile), reset automatically after 99999.9 km (mile) Display unit: 1 km (mile)												
○ Trip meter A/B	Display range: 0~999.9 km (mile), reset automatically after 999.9 km (mile) Display unit: 0.1 km (mile)												
○ Speeding warning light	Setting range: 30~180 km/h (20~110 MPH) Setting unit: 5 km/h (MPH)												
○ Top speed record	Display range: 0~360 km/h (0~223 MPH)												
○ Tire circumference	Setting range: 300~2,500 mm Setting unit: 1 mm • Pulse setting: 1~60												
● Tachometer	Display range: 0~10,000 / 20,000 RPM Display unit: 250 / 500 RPM												
○ Display internal	<0.5 second												
○ Shift light	Setting range: 5,000~10,000 / 20,000 RPM Setting unit: 100 RPM												
○ MAX RPM record	Display range: 0~10,000 / 20,000 RPM												
○ Stroke / piston setting	2 Stroke: 1, 2, 3, 4 pistons 4 Stroke: 1, 2, 3, 4, 5, 6, 8, 10, 12 pistons												
● Thermometer	Display unit: °C & °F for alternative												
● Digital thermometer (Water & oil temperature)	Display range: 0~250 °C (32~482 °F) Display unit: 0.1 °C (°F)												
● Thermometer level (Water temperature)	Display range: 20~120 °C (68~248 °F), 10 segment bar graph Display unit: 10 °C (50 °F) for each segment												
○ Display internal	<0.5 second												
○ Temperature alarm (Water & oil temperature)	Setting range: 60~250 °C (140~482 °F) Setting unit: 1 °C (°F)												
○ Top temperature record	Display range: 0~250 °C (32~482 °F)												
● Fuel level	Display range: 10 segment bar graph												
● Fuel meter	Display unit: 10 % for each segment Setting range: 100 Ω, 510 Ω, no display												
○ Insufficient fuel warning	Setting range: 10~50 % Setting unit: 10 %												
● Clock	24H												
● Target speed timer	Setting range: 30~360 km/h (20~220 MPH) Setting unit: 5 km/h (MPH)												
● Target distance timer	Setting range: 50~1,000 M (1/32~20/32 mile) Setting unit: 50 M (1/32 mile)												
● Top speed timer	The record including, 1. Speed: 0~360 km/h (0~223 MPH) 2. Distance: 0~999 M (0~3,280 feet) 3. Timer: 0~9'59"99 second.												
● Effective voltage	DC 12V												
● Effective temperature range	-10~+60 °C												
● Meter standard	JIS D 0203 S2												
● Meter size (W X L X H)	135.7 X 100.7 X 52 mm												
● Meter weight	Around 240 g												
● Telltales	<table border="0"> <tr> <td>ⓘ High beam (Blue)</td> <td>↔ Repeater (Green)</td> </tr> <tr> <td>N Neutral (Green)</td> <td>⚠ EOBD (Amber)</td> </tr> <tr> <td>⛽ Oil (Red)</td> <td>⚡ Speeding (Red)</td> </tr> <tr> <td>⚙ RPM shift light (Yellow / Red)</td> <td></td> </tr> <tr> <td>🌡 Temperature alarm (Red)</td> <td></td> </tr> <tr> <td>🔥 Temperature alarm (Red)</td> <td></td> </tr> </table>	ⓘ High beam (Blue)	↔ Repeater (Green)	N Neutral (Green)	⚠ EOBD (Amber)	⛽ Oil (Red)	⚡ Speeding (Red)	⚙ RPM shift light (Yellow / Red)		🌡 Temperature alarm (Red)		🔥 Temperature alarm (Red)	
ⓘ High beam (Blue)	↔ Repeater (Green)												
N Neutral (Green)	⚠ EOBD (Amber)												
⛽ Oil (Red)	⚡ Speeding (Red)												
⚙ RPM shift light (Yellow / Red)													
🌡 Temperature alarm (Red)													
🔥 Temperature alarm (Red)													



RX3

The RX-3 TFT multifunction meter is the newest addition to our RX series of gauges. It features a modern TFT screen to display your information with the day and night brightness adjustability and also has 5 different colors to choose from. Compact, lightweight and easy to operate, this modern meter offers a clean and simple design. This universal gauge can be used for any application.



**Fuel meter**  
 ● Display range : 6 levels  
 ● Display unit : Each level represents 16.6 %  
 Setting range : OFF、100 Ω、250 Ω、270 Ω、510 Ω、1200Ω、SW、Learning Mode

**Gear meter**  
 ● Display Type : Gear Learning、OFF  
 ● Display range : (Clutch Released)、N、1 ~ Top Gear. The top gear is according to the gear learning.

**Speedometer**  
 ● Display range: 0 ~ 360 km/h (0 ~ 223 MPH)  
 ● Display unit: km/h、MPH

Item number  
 Backlight color Display range



\* BA 0 7 1 0 0 0 \*



\* BA 0 7 1 1 0 0 \*

● Speedometer	Display range : 0~360 km/h (0~223MPH) Display unit : km/h、MPH
○ Odometer	Display range : 0~99,999 km (mile), reset when exceed Display unit : 1 km
● Adjustable Odometer	Setting range : 0~999,999 km (mile) adjustable Setting unit : 1 km
○ Trip meter A/B	Display range : 0~9,999.9 km (mile), can be reset Setting unit : 0.1 km (mile)
○ Maintenance Mileage	Setting range : 300~5,000 km (mile), OFF Setting unit : 100 km (mile)
○ Over-Speed Warning	Setting range : 30~360 km/h (20~223 MPH) Setting unit : 1 km/h (MPH)
○ MAX speed record	Display range : 0~360 km/h (0~223MPH) Display unit : 1km/h (MPH)
○ Tire circumference	Setting range : 300~2,500 mm Setting unit : 1 mm
○ Sensing Point	Setting range : 1~20P Setting unit : 1P
● Gear meter	Display Type : Gear Learning、OFF Display range : (Clutch Released)、N、1 ~ Top Gear. The top gear is according to the gear learning.
○ Top Gear Record (MAX)	Display range : -(Clutch Released)、N、1 ~ Top Gear. The top gear is according to the gear learning.
● Tachometer	Display range : 0~15,000RPM
○ Shift Light	Setting range : 1000~15,000 RPM Setting unit : 100RPM
○ MAX RPM record	Display range : 0~15,000RPM When in MAX Display, the needle shown the highest RPM.
○ The RPM input signal number setting	0.5、1.0~24.0
○ The RPM input pulse	Setting range : Low-Act、High-Act
● Digital thermometer	Display range : 0~250 °C(32~482°F) Display unit : 0.1 °C (°F)
○ Over heat Warning	Setting range : 60~250 °C (140~482°F) Setting unit : 1 (°F)
○ MAX thermometer record	Display range : 0~250 °C(32~482°F)
● Fuel meter	Display range : 6 levels Display unit : Each level represents 16.6 % Setting range : OFF、100 Ω、250 Ω、270 Ω、510 Ω、1200Ω、SW、Learning Mode

○ Insufficient fuel warning	Setting range : 0~3/6 Setting unit : 1
● Clock	Setting range : 12、24H Setting range : 00:00~23:59
● Digital Volt meter	Display range : DC 8.0~18.0 V Display unit : DC 0.1 V
○ Low Voltage warning	Setting range : DC 8.0~18.0 V Setting unit : DC 0.1 V
● Background Display	Setting range : AUTO(Optical Sensing) Positive、Negative
● Backlight brightness adjust	Setting range : 1/5(Darker)~5/5(Brighter) Setting unit : 1/5 °
● Backlight color	Setting range : White、Red、Orange、Green、Blue
● Target speed timer	Setting range : 30~360 km/h (20~223 MPH) Setting unit : 5 km/h (MPH)
○ Target distance timer	Setting range : 50~1,000 M (1/32~20/32 mile) Setting unit : 50 M (1/32 mile)
○ Top speed timer	Setting range : 1.Speed : 0~360 km/h (0~223 MPH) 2.Distance : 0~999 M (0~3,280 feet) 3.RPM : 0~15,000 RPM 4.Timer : 9:59'99
● Effective voltage	DC 12.V
● Effective temperature range	-10~+60°C
● Meter standard	JIS D 0203 S2
● Indicator light color	<ul style="list-style-type: none"> <li>↔ Turn signal(Green)</li> <li>ⓘ High beam(Blue)</li> <li>N Neutral(Green)</li> <li>⚠ EOB(Amber)</li> <li>⛽ Oil(Red)</li> <li>⚠ ABS(Yellow)</li> <li>● RPM shift light(Red)</li> <li>⚠ Warning Light(Red、OFF、Quick Flashing、Steady、Slow Flashing)</li> </ul>

RX3S

Stand out from the crowd! RX3S instrument re-define of entry-level aftermarket instrument. Newest 3.5" colorful TFT LCD display with brand new design user friendly interface make your bike upgrade not just one level higher! All the functions you need for speedometer, tachometer, odometer and trip, this instrument also include the gear position display, target distance and target speed these performance features to make your bike's information and condition become more colorful in your eyes. RX3S instrument, makes each ride become a journey of fun!



NEW!

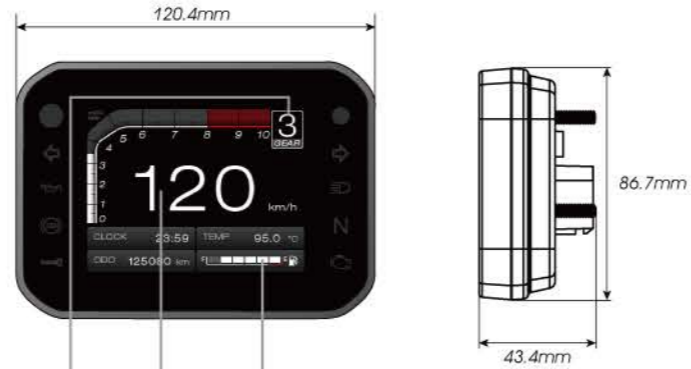

- Fuel meter**
  - Display range : 6 levels
  - Display unit : Each level represents 16.6 %
  - Setting range : OFF、100 Ω、250 Ω、270 Ω、510 Ω、1200Ω、SW、Learning Mode
- Speedometer**
  - Display range:0 ~ 360 km/h (0 ~ 223 MPH)
  - Display unit:km/h、MPH
- Gear meter**
  - Display Type : Gear Learning、OFF
  - Display range : (Clutch Released)、N、1 ~Top Gear.The top gear is accroding to the gear learning.

Item number  
Backlight color



5color  
\*BA07900\*

- Speedometer Display range : 0~360 km/h (0~223MPH)  
Display unit : km/h、MPH
- Odometer Display range : 0~99,999 km (mile), reset when exceed  
Display unit : 1 km
- Adjustable Odometer Setting range : 0~999,999 km (mile) adjustable  
Setting unit : 1 km
- Trip meter A/B Display range : 0~9,999.9 km (mile), can be reset  
Setting unit : 0.1 km (mile)
- Maintenance Mileage Setting range : 500~16,000 km (300~10,000 mile),OFF  
Setting unit : 100 km (mile)
- Over-Speed Warning Setting range : 30~360 km/h (20~223 MPH)  
Setting unit : 1 km/h (MPH)
- MAX speed record Display range : 0~360 km/h (0~223MPH)  
Display unit : 1km/h (MPH)
- Tire circumference Setting range : 300~2,500 mm  
Setting unit : 1 mm
- Sensing Point Setting range : 1~4T0P  
Setting unit : 1P
- Gear meter Display Type : Gear Learning、OFF  
Display range : (Clutch Released)、N、1 ~Top Gear.The top gear is accroding to the gear learning.
- Top Gear Record (MAX) Display range : -(Clutch Released)、N、1 ~Top Gear. The top gear is accroding to the gear learning.
- Tachometer Display range : 0~10,000、12,000、15,000、18,000、20,000 RPM
- Shift Light Setting range : 1000~10,000、12,000、15,000、18,000、20,000 RPM  
Setting unit : 100RPM
- MAX RPM record Display range : 0~10,000、12,000、15,000、18,000、20,000 RPM
- The RPM input signal number setting Setting range : 0.5、1.0~24.0
- The RPM input pulse Setting range : Low-Act、High-Act
- Digital thermometer Display range : 0~250 °C(32~482°F)  
Display unit : 0.1 °C (°F)
- Over heat Warning Setting range : 60~250 °C (140~482°F)  
Setting unit : 1 (°F)
- MAX thermometer record Display range : 0~250 °C(32~482°F)
- A/F ratio meter Display range : 12.1 ~ 17.5  
Display range : 0.1
- Fuel meter Display range : 6 levels  
Display unit : Each level represents 16.6 %  
Setting range : OFF、100 Ω、250 Ω、270 Ω、510 Ω、1200Ω、SW、Learning Mode
- Insufficient fuel waring Setting range : 0~3/6  
Setting unit : 1
- Clock Setting range : 24、12H  
Setting range : 00:00~23:59 (1:00~12:59)
- Digital Volt meter Display range : DC 0.1 V
- Low Voltage waring Setting range : DC 8.0~13.0 V  
Setting unit : DC 0.1 V
- High Voltage waring Setting range : DC 13.1~18.0 V  
Setting unit : DC 0.1 V
- Background Display Setting range : AUTO(Optical Sensing)  
Positive、Negative
- Backlight brightness adlust Setting range : 1/5(Darker)~5/5(Brighter)  
Setting unit : 1/5 °
- Backlight color Setting range : White、Orange、Yellow、Green、Blue
- Target speed timer Setting range : 30~360 km/h (20~223 MPH)  
Setting unit : 5 km/h (MPH)
- Target distance timer Setting range : 50~1,500 M (1/32~30/32 mile)  
Setting unit : 50 M (1/32 mile)
- Top speed timer Setting range :  
1.Speed : 0~360 km/h (0~223 MPH)  
2.Distance : 0~999 M (0~3,280 feet)  
3.RPM : 0~10,000、12,000、15,000、18,000、20,000 RPM  
4.Timer : 9:59:99
- Effective voltage DC 12 V
- Effective temperature range -20~+85°C
- Meter standard JIS D 0203 S2
- Indicator light color
  - Composite warning light(Red)
  - ↔ Turn signal(Green)
  - ⚡ Oil(Red)
  - ABS(Yellow)
  - 🚒 Security light(Red)
  - 🚗 High beam(Blue)
  - N Neutral(Green)
  - 🔧 EOBD(Amber)



RX4

Featuring speed, odometer, tripmeter, hour meter, voltage, clock and a stopwatch as well as several indicator lights, the new universal version of the RX-4 meter will give you all the information you need for your next trip.

This multifunction meter allows you to connect your phone through its Bluetooth option for a unique experience like no other standard meter. You can see your incoming call, your music playing information and much more. With its easy to use and large display functions, the RX-4 is the perfect meter to give a modern look for any type of bikes.



NEW!



- Thermometer A, B**
  - Display range : 0.0 ~ 250.0 °C (32.0 ~ 482.0 °F)
  - Display unit : 0.1 °C (°F)
- Odometer**
  - Display range : 0 ~ 999,999 km (mile) and then return to zero
  - Display unit : 1 km (mile)
- Trip meter A, B**
  - Display range : 0.0~9,999.9 km (mile), may return to zero manually
  - Setting unit : 0.1 km (mile)
- Speedometer**
  - Display range : 0 ~ 360 km/h (0 ~ 225 MPH)
  - Display unit : 1 km/h (MPH)
- Tachometer**
  - Display range : 0~10,000 RPM, 0~12,500 RPM, 0~15,000 RPM, 0~18,000 RPM

- Fuel meter**
  - Display range : 6 levels
  - Display unit : 1 level (16.6 %)
- Fuel warning**
  - Display range : The warning value for low fuel shall be 1 segment and below, the symbol will blink for warning.
- Gear Meter**
  - Display range : -, N, 1 ~ 6

Item number



\* B A 0 8 1 0 1 0 \*



● The music playing info screen.



● The incoming phone call notice screen.



● The navigation screen.



RS2

All new RS2 multifunction meter has completely User Interface design concept, more user friendly and easy to play with. All the functions you need for daily using. Speedometer, Tachometer, Odometer, Trip, Gear Position, Clock and even have the Dyno function to test target distance and target speed which allows you to have some fun with your bike! RS2 also has multiple backlight colors, so you could pick one like and suit your bike better, not to mentioned the backlight dimming function also can be setup so it will adjust the backlight brightness automatically for you in the night time. This new toy will bring your fun with the bike to the next level!

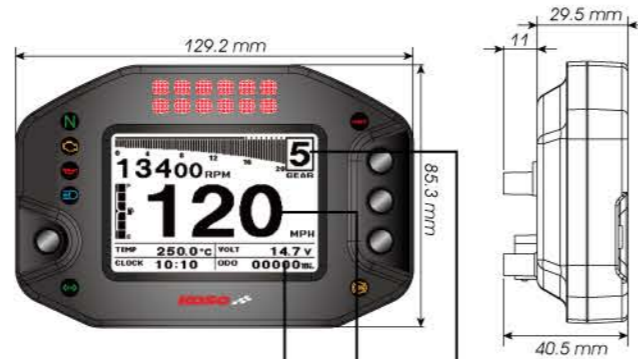

- Thermometer**
- Display unit : °C · °F Switchable
  - Display range : 0 ~ 250 °C (32 ~ 482 °F)
  - Display unit : 0.1 °C (°F)
- A/F ratio meter**
- Display range : 12.1 ~ 16.8
  - Display range : 0.1
- Clock**
- Display range : 24 H
- Volt**
- Display range : DC 8.0 ~ 18.0 V
  - Display unit : 0.1 V
- Odometer**
- Display range : 0 ~ 99,999 km (mile) return to zero upon exceed.
  - Display unit : 1 km (mile)
- Trip meter A · B**
- Display range : 0.0 ~ 9999.9 km (mile) return to zero upon exceed.

- Gear Meter**
- Display range : N · 1~6
- Speedometer**
- Display range : 0 ~ 360 km/h (0 ~ 223MPH)
  - Display unit : km/h (MPH) Switchable

Item number  
Backlight color · Display range · Panel color



\* BA 0 7 3 0 0 0 \*

8color 0 ~ 20,000 RPM Black

- Speedometer Display range : 0 ~ 360 km/h (0 ~ 223 MPH)  
Display unit : 1 km/h (MPH) for alternative
- Display internal <0.5 Second
- Odometer Display range : 0 ~ 99,999 km/h (MPH) reset automatically after 99,999 km (MPH).  
Display unit : 1 km/h (MPH)
- Trip meter A · B Display range : 0 ~ 9999.9 km/h (MPH) reset automatically after 9999.9 km (MPH).  
Display unit : 0.1 km/h (MPH)
- Speeding warning light Setting range : 0 ~ 90 km/h (0 ~ 56 MPH)  
Setting unit : 1 km/h (MPH)
- Top speed record (MAX) Display range : 0 ~ 360 km/h (0 ~ 223 MPH)  
Display unit : 1 km/h (MPH)
- Tire circumference Display range : 300~2,500 mm  
Display unit : 1 mm · Sensor point : 1 ~ 60
- Gear Meter Display range : N · 1~6 · OFF
- Digital Tachometer Display range : 0 ~ 20,000 RPM  
Display unit : 100 RPM
- Level Tachometer Display range : 0 ~ 9,000 · 12,000 · 15,000 · 18,000 · 20,000 RPM
- RPM shift light Setting range : 3,000 ~ 20,000 RPM
- Max RPM record Display range : 0 ~ 20,000 RPM
- RPM Signal (For Fuel Injection) Setting range : 0.5, 1 ~ 24
- Thermometer Display range : °C & °F for alternative
- Digital Thermometer Display range : 0 ~ 250.0 °C (32.0 ~ 482.0 °F)  
Setting range : 1 °C (°F)
- Temperature warning Setting range : 50 ~ 250.0 °C (122.0 ~ 482.0 °F)  
Display unit : 1 °C (°F)
- Top temperature (MAX) Display range : 0 ~ 250.0 °C (32.0 ~ 482.0 °F)
- A/F ratio meter Display range : 12.1 ~ 16.8  
Display range : 0.1
- Level Fuel Display range : 6 Level  
Display unit : 16.6 % each segment
- Fuel resistance setting Display range : 100 · 250 · 510 · 1200 · SW · Learning
- Low Fuel warning Setting range : 0 ~ 3/6  
Display unit : 1/16  
(At) lower than the setting value, warning FI light lit, fuel level glitter.
- Motor oil maintenance Setting range : 500 ~ 16,000 km  
(312 ~ 10,000 mile)
- ABS indicator Setting range : ON/OFF

- Clock Display range : 24 H
- Digital Volt meter Display range : DC 8.0 ~ 18.0 V  
Display unit : 0.1 V
- Target speed timer Setting range : 30 ~ 360 km/h (20 ~ 223 MPH)  
Setting unit : 5 km (MPH)
- Target distance timer Setting range : 50 ~ 1,500 M  
(1/32 ~ 30/32 MPH)  
Setting unit : 50 M (1/32 MPH)
- Top speed timer The record including  
Speed : 0 ~ 360 km/h (0 ~ 225 MPH)  
Distance : 0 ~ 999 M (0~3,280 feet)  
RPM : 0 ~ 20,000 RPM  
Display Range Timer : 9 : 59~99
- Display & Backlight Setting range : Time setting switchover  
(Positive and Negative [nighttime function is turned off when  
Display of the Main Screen] the before and after time is the same)
- Back light color Setting range : White · Green · Light Blue · Blue · Purple · Red · Orange · Yellow
- Liquid Crystal Concentration Setting range : 1/3(Darkest) ~ 3/3(Brightest)
- Back light brightness Setting range : 1/5(Darkest) ~ 5/5(Brightest) ;  
light Separate setting for daytime and nighttime
- Brightness (LED Bar) Setting range : 1/5(Darkest) ~ 5/5(Brightest) ;  
Separate setting for daytime and nighttime
- Supply voltage DC 12 V
- Effective temperature range -10 ~ +60 °C
- Meter standard JIS D 0203 [S2]
- Meter size 129.2 x 85.3 x 40.5 mm
- Meter weight Around 151 g
- Indicator light color Neutral (green light) N  
Engine (yellow light) E  
Motor oil (red light) M  
High beam light (blue light) H  
Indication light (green light) I  
IMMO (red light) IMMO  
ABS (yellow light) ABS

Unlimit

# MS-01



050 / 051



NEW!



**Speedometer**

- Display range : 0-199 km/h (0-124 MPH)
- Display unit : 1 km/h (MPH)

**Tachometer (LCD Bar)**

- Display Range :
- 0 ~ 10,000 RPM (250 RPM each segment)
- 0 ~ 13,000 RPM (250 RPM each segment)
- Tachometer (Number)
- \*Displays when the gear function is turned off
- Display Range :
- 0 ~ 10,000 RPM (100 RPM each segment)
- 0 ~ 13,000 RPM (100 RPM each segment)

**Gear meter**

(When the gear function is off, the speed function is displayed.)

- Display range : OFF, highest gear, N and highest gear, show all (N / 1 - 6)

**Fuel meter**

- Display Range : OFF - 6 Levels

Item number



\*BA078100\*

E-mark approval

## MS-01

The MS-01 multifunction meter is the newest addition for enthusiasts who enjoy multiple readings from their ride. It features a modern negative LCD screen to display all of your information.

Compact, lightweight and easy to operate, this modern meter offers a clean and simple design. This universal gauge can be used for any application.



Unlimit

MS-01

Unlimit 2024

## XR-01S

Thinner and lighter than its previous version the XR-SA, our innovative XR-01S most importantly feature a larger, higher quality and easy to read LCD display. The indicator light functions are still there; however we have added one more, which makes a total of 6 indicator light. New interesting functions were added and they include a 2 hour meter readings, a maintenance hour meter for oil change, 2 trip meter readings, and a useful clock. The XR-01S is simplicity at its best. This meter is user-friendly, easy to read during day or night, and is a great fit for any kind of motorcycle, scooter or other bike.



- Speedometer Display range : 0 ~ 360 km/h (0 ~ 225 MPH)  
Display unit : km/h or MPH for alternative
- Odometer Display range : 0 ~ 99,999 km (mile), reset automatically after 99,999 km (mile) · Setting unit : 1 km (mile)
- Trip meter A · B Display range : 0 ~ 9,999.9 km (mile), reset automatically after 9,999.9 km (mile) · Display unit : 0.1 km (mile)
- Oil maintenance mileage Setting range : 300 ~ 5,000 km (mile)  
Setting unit : per 100 km (mile)
- Hour meter Display range : 99,999 hour, reset automatically after 99,999 hour · Display unit : 1 hour
- Hour meter A · B Display range : 9,999.9 hour, reset automatically after 9,999.9 hour · Display unit : 0.1 hour
- MAX speed record Display range : 0 ~ 360 km/h (0 ~ 225 MPH)
- Average speed record Display range : 0 ~ 360 km/h (0 ~ 225 MPH)
- Tire circumference Setting range : 300 ~ 2,500 mm  
Setting unit : 1 mm · Sensitive point : 1 ~ 6
- Fuel meter Display range : 6 grids
- Insufficient fuel warning Setting unit : 100 Ω · 250 Ω · 510 Ω · USER
- Clock 24 H
- Volt meter Display range : DC 8.0 ~ 18.0 V
- Volt meter warning Display range : Flashing warning when voltage lower than 11.5 V or higher than 15.5 V
- Effective voltage DC 12 V
- Effective temperature range -10 ~ +60 °C
- Meter standard JIS D 0203 S2
- Meter size 77.5 X 74.8 X 34 mm
- Meter weight Around 87 g
- Indicator light color Turn signal (Green) · Neutral (Green) · Warning Light (Red) · Engine Light (Yellow) · High beam light (Blue)

Item number  
Backlight color · Display range · Panel color



White 0-360 km/h



- Speedometer Display range : 0 ~ 360 km/h (0 ~ 225 MPH)  
Display unit : km/h or MPH for alternative
- Odometer Display range : 0 ~ 99,999 km (mile), reset automatically after 99,999 km (mile) · Setting unit : 1 km (mile)
- Trip meter A · B Display range : 0 ~ 9,999.9 km (mile), reset automatically after 9,999.9 km (mile) · Display unit : 0.1 km (mile)
- Oil maintenance mileage Setting range : 300 ~ 5,000 km (mile)  
Setting unit : per 100 km (mile)
- Hour meter Display range : 99,999 hour, reset automatically after 99,999 hour · Display unit : 1 hour
- Hour meter A · B Display range : 9,999.9 hour, reset automatically after 9,999.9 hour · Display unit : 0.1 hour
- MAX speed record Display range : 0 ~ 360 km/h (0 ~ 225 MPH)
- Average speed record Display range : 0 ~ 360 km/h (0 ~ 225 MPH)
- Tire circumference Setting range : 300 ~ 2,500 mm  
Setting unit : 1 mm · Sensitive point : 1 ~ 6
- Fuel meter Display range : 6 grids
- Insufficient fuel warning Setting unit : 100 Ω · 250 Ω · 510 Ω · USER
- Clock 24 H
- Volt meter Display range : DC 8.0 ~ 18.0 V
- Volt meter warning Display range : Flashing warning when voltage lower than 11.5 V or higher than 15.5 V
- Effective voltage DC 12 V
- Effective temperature range -10 ~ +60 °C
- Meter standard JIS D 0203 S2
- Meter size 77.5 X 74.8 X 34 mm
- Meter weight Around 87 g

Item number  
Backlight color · Display range · Casing



White 0-360 km/h

## XR-01

Thinner and lighter than its previous version the XR-S, our innovative XR-01 most importantly features a larger, higher quality and easy to read LCD display. New interesting functions were added such as a 2 hour meter readings, a maintenance hour meter for oil change, 2 trip meter readings, and a useful clock. This meter is simple, user-friendly, and easy to read during day or night riding. The XR-01 meter is a great fit for any kind of motorcycle, scooter, ATV and more!



E-mark approval

# XR-SRN+

The XR-SR multi-functions speedometer was designed especially for motorcycles and ATVs. Its digital screen will provide important informations on your engine. The 8 indicator lights can be adapted to all motorcycles and ATVs. Its great shape and digital display will make your bike look different!



**Tachometer**

- Display range: 0~18,000 RPM.
- Display unit: 100 RPM.

**Clock**

- 24H

**Level thermometer**

- Display range: 20~120°C (68~248°F), 10 levels.
- Display unit: Each level represents 10°C (50°F).



Item number  
Backlight color: Display range: Panel color



\* BB017B60 \*  
Blue 0~18,000 RPM Black

### Option accessory

<p><b>1</b> Disc magnet screw</p> <p>Size: 18 x 22, 11, 12 M6 X P1.0 X 12.0L M6 X P1.0 X 15.0L M6 X P1.0 X 18.0L M6 X P1.0 X 21.0L M6 X P1.0 X 24.0L M6 X P1.0 X 27.0L M6 X P1.0 X 30.0L</p>	<p><b>2</b> Active speed sensor</p>	<p><b>3</b> Digital speed signal sensor</p> <p>JIS TYPE A</p>	<p><b>4</b> Digital speed signal sensor</p> <p>JIS TYPE A</p>
<p><b>5</b> Digital speed signal sensor</p> <p>BI-WIRE</p>	<p><b>6</b> Digital speed signal sensor</p> <p>X-FIELD BOOSTER</p>	<p><b>7</b> L type speed sensor bracket</p>	<p><b>8</b> Temp sensor wire set (2 M)</p>
<p><b>9</b> Oil temp sensor adapter</p> <p>M12 X P1.5 X 10L M14 X P1.5 X 10L M14 X P1.5 X 15L M16 X P1.5 X 15L M16 X P1.5 X 20L M20 X P1.5 X 15L M20 X P1.5 X 20L</p>	<p><b>10</b> Water temp sensor adapter</p> <p>M14 M16, M18 M22, M26 mm</p>	<p><b>11</b> Temp sensor</p> <p>M10 X P1.0 M12 X P1.0 M14 X P1.0 M16 X P1.0 M18 X P1.0</p>	<p><b>12</b> Cylinder head temp sensor</p> <p>M10 M14 mm</p>



● Speedometer	Display range: 0~360 km/h (0~225 MPH) Display unit: km/h & MPH for alternative
○ Display internal	<0.5 second
○ Odometer	Display range: 0~99999.9 km (mile), reset automatically after 99999.9 km (mile) Display unit: 0.1 km (mile)
○ Trip meter A/B	Display range: 0~999.9 km (mile), reset automatically after 999.9 km (mile) Display unit: 0.1 km (mile)
○ Top speed record	Display range: 0~360 km/h (0~225 MPH)
○ Tire circumference	Setting range: 300~2,500 mm Setting unit: 1 mm • Pulse setting: 1~20
● Tachometer	Display range: 0~18,000 RPM Display unit: 100 RPM
○ Display internal	<0.5 second
○ MAX RPM record	Display range: 0~18,000 RPM
○ The RPM input signal number setting	Setting range: 0.5, 1~24
○ The RPM input pulse	Setting range: HI (The positive wave pulse) Lo (The negative wave pulse)
● Thermometer	Display unit: °C & °F for alternative
● Digital thermometer	Display range: 0~120°C (32~248°F) Display unit: 0.1°C (°F)
● Thermometer level	Display range: 20~120°C (68~230°F), 10 segment bar graph Display unit: 10°C (50°F) for each segment
○ Top temperature record	Display range: 0~120°C (32~248°F)
● Fuel level	Display range: 10 segment bar graph Display unit: 10 % for each segment Setting range: 100Ω, 250Ω, 510Ω, 1200Ω, SW
○ Fuel warning	Setting range: 10~50% ; Setting unit: 10%
● Clock	24H
● Volt meter	Display range: DC 8~18 V. Flashing warning when Voltage lower than 11.5 V or higher than 15.5 v.
● Top speed timer	The record including, Speed : 0~360 km/h (0~225 MPH) Distance : 0~999 M (0~3280 feet) Timer : 0~9'59"99 seconds
● Effective voltage	DC 12V
● Effective temperature range	-10~+60°C
● Meter standard	JIS D 0203 S2
● Meter size (W X L X H)	116.3 X 72.4 X 32.3 mm
● Meter weight	Around 286 g
● Telltales	↔ Repeater (Green) ⬇ Low beam (Green) ⬆ High beam (Blue) N Neutral (Green) ⚠ Hazard (Red light) ⬇ Temperature alarm (Red) ⬇ Oil (Red)



### EX-02S

With its modern look, this EX-02S is the perfect meter for all dual applications. Its illuminated backlight makes the instrument very easy to read even when you ride at night. The EX-02S is equipped with all basic function and more. Featuring speed, odometer, trip meter, hour meter, voltage, clock and stopwatch as well as 6 indicator lights, this meter will give you all information you need.



- Speedometer Display range: 0~360 km/h (0~225 MPH)  
Display unit: km/h & MPH for alternative
- Display internal <0.5 second
- Odometer Display range: 0~99999 km (mile),  
reset automatically after 99999km (mile)  
Display unit: 1 km (mile)
- Trip meter Display range: 0~9999.9 km (mile),  
reset automatically after 9999.9 km (mile)  
Display unit: 0.1 km (mile)
- Hour mete Display range: 0~9999.9 hour  
reset automatically after 9999.9 hour  
Display unit: 0.1 hour
- Clock 12/24 MODE
- Volt 8~18V
- Inner Battery Level Display range: 4 levels.
- Clock 12/24 MODE
- Supply voltage DC 12V
- Effective temperature range -10~+60°C
- Meter standard JIS D 0203
- Meter size (W X L X H) 120 X 40 X 23mm
- Meter weight
- Indicator light color
  - ⬆ High beam light (Blue)
  - ↔ Direction light (Green)
  - ⚡ Engine Light (Yellow)
  - N Neutral (Green)
  - ⚠ Warning Light (Red)

Item number  
Backlight color Display range Panel color



White On road Black

Option accessory

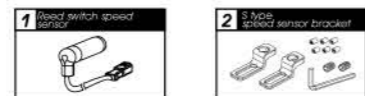

- Speedometer**
  - Display range : 0~360 km/h(0~225 MPH).
  - Display unit : 1 km/h (MPH) for alternative.
- Odo meter**
  - Display range : 0~99,999 km(mile).
  - Display unit : 1 km(mile).
- Trip meter**
  - Display range : 0.0~9,999.9 km(mile).
  - automatically reset after 9,999.9 km(mile).
  - Display unit : 0.1 km(mile).
- Indicator light**
  - Right indication light (Green)
  - Motor oil light (Red)
  - Low fuel warning light (Amber)
  - Water temperature light (Red)
  - Neutral light (Green)
  - High beam light (Blue)
  - Left indication light (Green)
  - Engine light (Amber)
- Clock**
  - Display range : 24H, 12H.
- Volt meter**
  - Display range : DC 8.0~18.0 V.
- Max Record function**
  - Average speed : 0~360 km/h(0~225 MPH)
  - Max speed : 0~360 km/h(0~225 MPH)
  - Max voltage : DC 8.0~18.0 V

Item number  
Backlight color Display range Casing



White 0~360 km/h Black

### EX-03

This EX-03 speedometer is the perfect solution for all Enduro applications. Lightweight, compact and using a convenient speed sensor bracket, it can be quickly installed on most dirt bikes. The EX-03 speedometer features all the basic functions such as speed, odometer, trip meter, hour meter, voltage, stopwatch and clock. This meter also has the illuminated background with adjustable brightness that allows a good visibility of the display whether your ride on a bright sunny day or at night time.



## DB-01R+

Our DB-01R+ is an upgraded version of our popular DB-01R. Perfect for motorcycle, street fighters or dual-sports motorcycle, this meter features a large LED display which uses 3 different colors changeable backlights to make it easier to read during day or night riding. Get every information you need on this unique and lightweight meter that will enhance your motorcycle.



- Speedometer Display range: 0~360 km/h (0~224 MPH)  
Display unit: km/h & MPH for alternative
- Display internal <0.5 second
- Odometer Display range: 0~99999 km (mile), reset automatically after 99999 km (mile).  
Display unit: 0.1 km (mile)
- Trip meter A/B Display range: 0~999.9 km (mile), reset automatically after 999.9 km (mile)  
Display unit: 0.1 km (mile)
- Tire circumference Setting range: 300~2,500 mm  
Setting unit: 1 mm Sensitive point: 1~20
- Bar graph tachometer Display range: 10,000, 12,000, 15,000 RPM  
Display unit: 500 RPM
- Display Internal <0.5 second
- RPM input pulse Range: 0.5, 1, 1.5, 2, 2.5, 3, 4, 5, 6
- Fuel meter Display range: 6 levels  
Display unit: Each level represents 16.6 %  
Setting range: 100Ω, 250Ω, 510Ω, 1200Ω
- Insufficient fuel warning Display range: The fuel reserve symbol begins to flash if only 1 grids left  
When Stage 0, the fuel indicator will light up
- Effective voltage DC 12V
- Effective temperature range -10~+60°C
- Meter standard JIS D 0203 S2
- Meter size (W X L X H) 130 X 54 X 42.5 mm
- Meter weight Around 90 g
- Telltales  
N Neutral (Green) ; H High beam (Blue)  
↔ Direction (Green) ; F Fuel (Yellow)  
O Oil (Red) ; E EOB (Amber)

Item number  
Backlight color Display range Panel color



Barcode  
Blue Black



- Speedometer Display range : 0 ~ 360 km (0 ~ 225 mile)  
Will blink when exceed range.
- Odometer Display range : 0 ~ 99,999.9 km (mile), return to zero upon exceed.
- Trip meter A · B Display range : 0 ~ 999.9 km (mile), return to zero upon exceed.
- Motor oil maintenance Display range : Metric Unit :500 (~ 8,000 km, user adjustable) ~ 999 km, automatic decrease according to the increase of total mileage.
- Maximum speed record Display range : 0 ~ 360 km (0 ~ 225 mile)
- Average speed record Recording range : 0 ~ 360km/h (0 ~ 225 MPH)
- Tire circumference Setting range : 300 ~ 2,500 mm
- Sensitive point Setting range : 1 ~ 20 points
- Tachometer Display range : 0 ~ 10,000 RPM · 0 ~ 12,000 RPM · 0 ~ 15000 RPM
- The RPM input signal number setting Setting range : P-0.5, P-1 ~ P-25
- Total hour meter Display range : 0 ~ 99,999.9 hour
- The RPM input pulse Setting range : lo-Act, HI-Act
- Hour meter A · B Display range : 0 ~ 9,999.9 hour
- Fuel level Setting range : 100Ω · 250Ω · 270Ω · 510Ω · 1200Ω · SWITCH · USER
- Staged fuel gauge Warning range : Fuel level warning stage below (including) setting value, fuel level symbol will blink.
- Digital fuel gauge Setting range : 0 ~ 100 %
- Low fuel warning Setting range : 10 ~ 50 %, when lower than (including) setting value, fuel level symbol will blink.
- Volt meter Display range : DC8.0 V ~ 16.0 V
- Clock format Setting range : 12-hrs format, 24-hrs format
- Internal ODO Display range : 0~99999.9 km (mile), user unadjustable.
- External ODO Setting range : 0~99999 km (mile)
- Effective voltage DC 12 V
- Effective temperature range -10 ~ +60 °C
- Meter standard JIS D 0203 (S2)
- Meter size / Meter weight 120 x 46 x 20 mm / Around 240 g
- Indicator light Neutral (green) Right indication light (green) Water temperature (red)  
Motor oil (red) High beam light (blue) Left indication light (green)  
Fuel (yellow) Engine (yellow)

Item number  
Backlight color Display range Casing



Barcode  
White 0~360 km/h Black



## DB-01RN

Our DB-01RN is a complete multifunction meter that will look perfect on your sports bike, street fighter or dual-sports motorcycle. It's large motorcycle and sleek design shape will give your motorcycle a unique look. Want something different? Set your motorcycle apart with the KOSO DB-01RN meter!



DB-02

The new DB-02 works with the inner battery is designed for the off-road bike without battery. With the new dynamic design shape, the DB-02 could fit your off-road bike or ATV well. With the changeable bar graphic tachometer function, you could adjust the bar graphic tachometer to fit different types engine as you need. Except that, the new designed 3 stage shift light could make you to make the gear shift timing perfect. Besides that, we add the digital tachometer function, so you could also switch the digital speedometer to digital tachometer when you want to use the meter on the race.



3 stages RPM shift light

- Setting range: 5,000~20,000 RPM
- Setting unit: 100 RPM



Speedometer

- Display range: 0~360 km/h (0~225 MPH)
- Display unit: km/h & MPH for alternative.

Digital Tachometer

- Display range: 20,000 RPM.
- Display unit: 10 RPM.



Speeding warning light



Temperature alarm



Max. record

Item number  
Backlight color Display range Panel color



Attention!



\* B A 0 2 2 W 0 0 \*  
White 0~20,000 RPM Black

\* B F 6 5 0 J 0 2 \*  
DB02 ONLY Black

Option accessory

- 1 Disc magnet screw  
M16-P1.5 X 22.0  
M5 X P0.8 X 12.0  
M6 X P1.0 X 13.0  
M6 X P1.0 X 10.0  
M6 X P1.0 X 24.0  
M6 X P1.25 X 22.5  
M6 X P1.25 X 28.0
- 2 L type speed sensor bracket
- 3 Temp sensor wire set (2 M)
- 4 Oil temp sensor adaptor  
M12 X P1.5 X 15.0  
M12 X P1.25 X 15.0  
M12 X P1.0 X 15.0  
M12 X P1.0 X 19.0  
M12 X P1.0 X 30.0  
M12 X P1.25 X 27.5  
M12 X P1.25 X 28.0
- 5 Water temp sensor adaptor  
M14  
M16, M18  
M22, M26 mm
- 6 Temp sensor  
M10 X P1.0  
M12 X P1.5  
M14 X P1.25  
M14 X P1.5  
M16 X P1.5 / M18 X P1.5
- 7 Cylinder head temp sensor  
M10  
M14 mm



Temperature alarm A/B

- Display range: 60~250°C (140~482°F)
- Display unit: 1°C [°F]

Volt meter

- Display range: DC 0~18.0 V
- Display unit: DC 0.1 V

Fuel meter

- Display range: 0~100%
- Setting range: 100 Ω, 510 Ω, no display

Clock

- 24 H



Target Speed timer test



Target distance timer test



Top speed test

Item number  
Backlight color Display range Panel color



\* B A 0 2 2 W 1 0 \*  
White 0~20,000 RPM Black

Option accessory

- 1 Disc magnet screw  
M16-P1.5 X 22.0  
M5 X P0.8 X 12.0  
M6 X P1.0 X 13.0  
M6 X P1.0 X 10.0  
M6 X P1.0 X 24.0  
M6 X P1.25 X 22.5  
M6 X P1.25 X 28.0
- 2 L type speed sensor bracket
- 3 Temp sensor wire set (2 M)
- 4 Oil temp sensor adaptor  
M12 X P1.5 X 15.0  
M12 X P1.25 X 15.0  
M12 X P1.0 X 15.0  
M12 X P1.0 X 19.0  
M12 X P1.0 X 30.0  
M12 X P1.25 X 27.5  
M12 X P1.25 X 28.0
- 5 Water temp sensor adaptor  
M14  
M16, M18  
M22, M26 mm
- 6 Temp sensor  
M10 X P1.0  
M12 X P1.5  
M14 X P1.25  
M14 X P1.5  
M16 X P1.5 / M18 X P1.5
- 7 Cylinder head temp sensor  
M10  
M14 mm

DB-02R

The new DB-02R is designed for the street bike with battery. With the elegant white Backlight, the meter display will become very clear in the night time. Same as the DB-02, the meter comes with the changeable graphic tachometer which could fit almost all kinds of engines on the market. Except the function DB-02 has, the DB-02R comes with the power test function for you to test the performance of your bike. The new added engine hour meter is designed for you to maintain the engine especially for the dirt bike or ATV.





# Unlimit

## DB-02

●Speedometer	Display range: 0~360 km/h (0~225 MPH) Display unit: km/h & MPH for alternative <0.5 second
○Display internal	<0.5 second
○Odometer	Display range: 0~99999 km (mile), reset automatically after 0~99999 km (mile) Display unit: 1 km (mile)
○Trip meter A/B	Display range: 0~999.9 km (mile), reset automatically after 0~999.9 km (mile) Display unit: 0.1 km (mile)
○Speeding warning light	Setting range: 30~360 km/h (19~225 MPH) Setting unit: 1 km/h (MPH)
○Top speed record	Display range: 0~360 km/h (0~225 MPH)
○Tire circumference	Setting range: 300~2,500 mm Setting unit: 1 mm • Sensor point: 6
●Digital Tachometer	Display range: 20,000 RPM Display unit: 10 RPM
●Bar graph tachometer	Display range: 10,000 RPM, 60 segment bar graph Display unit: 166 RPM for each segment Display range: 15,000 RPM, 60 segment bar graph Display unit: 250 RPM for each segment Display range: 20,000 RPM, 60 segment bar graph Display unit: 333 RPM for each segment
○RPM shift light	Display range: 5,000~20,000 Display unit: 100 RPM
○Pre-shift light A/B	Display range: -500~-5,000 before the shift light Display unit: 100 RPM
○Max. RPM record	Display range: 0~20,000 RPM
○RPM input pulse	Display range: 0.5, 1, 1.5, 2, 2.5, 3, 4, 5, 6
●Hour meter	Display range: 0~999.9 H Display unit: 0.1 H (6 S)
●Thermometer	Display unit: °C & °F for alternative
●Thermometer A/B	Display range: 0~250°C (32~482°F) Display unit: 0.1°C (°F)
○Display internal	<0.5 second
○Temperature alarm A/B	Display range: 60~250°C (140~482°F) Display unit: 1°C (°F)
○Top temperature record	Display range: 0~250°C (32~482°F)
●Volt meter	Display range: DC 0~18.0 V Display unit: DC 0.1 V
●Backlight	DC 12V
●Battery type (LCD display)	CR 2032
●Battery life time	Around 220 hours nonstop
●Effective temperature range	-10~+60°C
●Meter standard	JIS D 0203 S2
●Meter size	100 X 60 X 20 mm
●Meter weight (W X L X H)	Around 200 g
●Telltails	● Speeding (Red) ● Temperature alarm A/B (Red) ● RPM shift light A (Yellow) ● RPM shift light B (Orange) ● RPM Shift light (Red)

## DB-02R

●Speedometer	Display range: 0~360 km/h (0~225 MPH) Display unit: km/h & MPH for alternative <0.5 second
○Display internal	<0.5 second
○Odometer	Display range: 0~99999 km (mile), reset automatically after 0~99999 km (mile) Display unit: 1 km (mile)
○Trip meter A/B	Display range: 0~999.9 km (mile), reset automatically after 0~999.9 km (mile) Display unit: 0.1 km (mile)
○Speeding warning light	Setting range: 30~360 km/h (19~225 MPH) Setting unit: 1 km/h (MPH)
○Top speed record	Display range: 0~360 km/h (0~225 MPH)
○Tire circumference	Setting range: 300~2,500 mm Setting unit: 1 mm • Sensor point: 20
●Digital Tachometer	Display range: 20,000 RPM Display unit: 10 RPM
●Bar graph tachometer	Display range: 10,000 RPM, 60 segment bar graph Display unit: 166 RPM for each segment Display range: 15,000 RPM, 60 segment bar graph Display unit: 250 RPM for each segment Display range: 20,000 RPM, 60 segment bar graph Display unit: 333 RPM for each segment
○RPM shift light	Display range: 5,000~20,000 Display unit: 100 RPM
○Pre-shift light A/B	Display range: -500~-5,000 before the shift light Display unit: 100 RPM
○Max. RPM record	Display range: 0~20,000 RPM
○RPM input pulse	Display range: 0.5, 1, 1.5, 2, 2.5, 3, 4, 5, 6
●Hour meter	Display range: 0~999.9 H Display unit: 0.1 H (6 S)
●Thermometer	Display unit: °C & °F for alternative
●Thermometer A/B	Display range: 0~250°C (32~482°F) Display unit: 0.1°C (°F)
○Display internal	<0.5 second
○Temperature alarm A/B	Display range: 60~250°C (140~482°F) Display unit: 1°C (°F)
○Top temperature record	Display range: 0~250°C (32~482°F)
●Fuel meter	Display range: 0~100% Setting range: 100Ω, 510Ω, no display Setting range: 10~50 % Setting unit: 10 %
○Insufficient fuel warning	Setting range: 10~50 % Setting unit: 10 %
●Volt meter	Display range: DC 0~18.0 V Display unit: DC 0.1 V
●Target speed timer	Setting range: 30~360 km/h (20~225 MPH) Setting unit: 5 km/h (MPH)
●Target distance timer	Setting range: 1/32~30/32 mile (50~1,500 M) Setting unit: 1/32 mile (50 M)
●Top speed timer	The record including, 1. Speed: 0~360 km/h (0~225 MPH) 2. Distance: 0~999 M (0~3,280 feet) 3. RPM: 0~20,000 RPM 4. Timer: 0~9'59"99 second.
●Effective voltage	DC 12V
●Effective temperature range	-10~+60°C
●Meter standard	JIS D 0203 S2
●Meter size	100 X 60 X 20 mm
●Meter weight (W X L X H)	Around 200 g
●Telltails	● Speeding (Red) ● Temperature alarm A/B (Red) ● RPM shift light A (Yellow) ● RPM shift light B (Orange) ● RPM Shift light (Red)



●Effective voltage	DC 12 V
●Effective temperature range	-10~+60°C
●Meter standard	JIS D 0203 S2
●Meter size (W X L X H)	141.5 X 72.4 X 18.4 mm
●Meter weight	Around 68.5g

Item number Backlight color Display range Panel color



\* B A 0 2 2 0 0 0 \* Black

Option accessory

* B 0 0 1 3 6 0 0 *	* B 0 0 1 3 6 0 2 *	* B 0 0 1 3 R 0 1 *
Green	Black	Red
* B 0 0 1 3 B 0 0 *	* B 0 0 1 3 G 0 3 *	* B 0 0 1 3 Y 0 3 *
Blue	Green	Yellow
* B 0 0 1 3 R 0 2 *	* B 0 0 1 3 G 0 4 *	* B 0 0 1 3 R 0 4 *
Red	Green	Red
* B 0 0 1 3 O 0 *	* B 0 0 1 3 R 0 1 *	* B 0 0 1 3 R 0 3 *
Orange	Red	Red
* B 0 0 1 3 K 0 0 *	* B 0 0 1 3 Y 0 1 *	* B 0 0 1 3 R 0 5 *
Black	Orange	Red

## E-mark approval

### THE PLUG-IN INDICATOR KIT FOR DB-02 & DB-02R

The indicator light kit is developed for the DB-02 & DB-02R meter for on-road use. Unlike the indicator light kit in the market, the new indicator light kit comes with different telltale symbols, so you could assemble it according to your own demands. There is no need to force yourself to fit some kit doesn't match your bike any more.



# DB-03R

The DB-03R is the perfect fit for any street bikes. Its blue backlight makes it very easy to read at night even at high speed. The integrated indicator lights do provide all the necessary information for any street use. The changeable RPM scale allows this gauge to fit about any engine applications. This instrument also features a gear indicator and shift light which will allow you to shift in the perfect gear. Beside those great functions, the DB-03R features: speed, odometer, trip meter, RPM, temperature, volt, fuel level and a lot more!



**The RPM Red, Yellow shift light**

- Setting range: 1,000~15,000 RPM
- Setting unit: 100 RPM
- Warning: Light on (F-OFF), Flash (F-ON)

**Temperature warning**

- Setting range: 60~250°C (140~482°F)
- Setting unit: 1°C (°F)



Temperature alarm



MAX record

Item number	Backlight color	Display range	Panel color
3	3color	Universal	Black
4	3color	Honda MSX	Black



3color	Universal	Black
3color	Honda MSX	Black

Option accessory

- 1 Disc magnet screw  
M4-M6 x 22.0  
M5 x 9.5 x 12.0  
M6 x 21.0 x 12.0  
M6 x 21.0 x 10.0  
M6 x 21.0 x 10.0  
M6 x 21.0 x 10.0  
M6 x 21.0 x 10.0
- 2 L type speed sensor bracket
- 3 Temp sensor wire set (2 M)
- 4 Oil temp sensor adaptor  
M12 x P1.5 x 10.0  
M12 x P1.5 x 15.0  
M12 x P1.5 x 20.0  
M12 x P1.5 x 25.0  
M12 x P1.5 x 30.0  
M12 x P1.5 x 35.0
- 5 Water temp sensor adaptor  
M14  
M16, M18  
M22, M26, mm
- 6 Temp sensor  
M10 x P1.0  
M12 x P1.5  
M14 x P1.25  
M14 x P1.5  
M16 x P1.5 / M18 x P1.5
- 7 Cylinder head temp sensor  
M10  
M14 mm



- Speedometer Display range: 0~360 km/h (0~225 MPH)  
Display unit: km/h (MPH), for alternative
- Display internal <0.5 second
- Odometer Display range: 0~99999 km (mile),  
reset automatically after 99999 km (mile)  
Display unit: 1 km (mile)
- Trip meter A/B Display range: 0~999.9 km (mile),  
reset automatically after 999.9 km (mile)  
Display unit: 0.1 km (mile)
- Speeding warning Setting range: 30~360 km/h (19~225 MPH)  
Setting unit: 1 km/h (MPH)
- Total hour meter Display range: 0~99999 H  
Display unit: 1 H
- Hour meter A/B Display range: 0.0~999.9 H  
Display unit: 0.1 H
- Tire circumference Setting range: 300~2,500 mm  
Setting unit: 1 mm • Sensitive point: 1~20
- Tachometer Display range: 0~10,000 / 0~12,000 / 0~15,000 RPM  
Display unit: 10,000 RPM-Each level represents 166 RPM,  
12,000 RPM-Each level represents 200 RPM,  
15,000 RPM-Each level represents 250 RPM
- Display internal <0.5 second
- The RPM Red, Yellow shift light Setting range: 1,000~15,000 RPM  
Setting unit: 100 RPM
- Warning Light on (F-OFF) / Flash (F-ON)
- MAX RPM record Display range: 0~10,000 / 0~12,000 / 0~15,000 RPM
- The RPM input signal number setting Setting range: 0.5, 1~24
- The RPM input pulse Setting range: HI (The positive wave pulse)  
Lo (The negative wave pulse)
- Temperature unit Display unit: °C & °F for alternative
- Thermometer Display range: 0.0~250.0°C (32.0~482.0°F)  
Display unit: 0.1°C (°F)
- Over heat warning (Water temperature) Setting range: 60~250°C (140~482°F)  
Setting unit: 1°C (°F)
- Top temperature record Display range: 0~250°C (32~482°F)
- Gear meter Display range: N, 1, 2, 3, 4, 5, 6, 7, 8, 9
- Fuel meter Display unit: Each level represents 16.6 %  
Setting range: 100Ω, 250Ω, 510Ω, 1200Ω, SW
- Clock 24H
- Volt meter Display range: DC 8~18 V. Flashing warning  
when Voltage lower than 11.5 V or higher than 15.5 v
- Backlight brightness Setting range: 1-5 (Darkest)~5-5 (Brightest)  
Right Display unit: Each level represents 20 %
- Backlight color Setting range: blue, orange, light purple
- Effective voltage DC 12V
- Effective temperature range -10~+60°C
- Meter standard JIS D 0203 S2
- Meter size (W X L X H) 120 X 68.5 X 44.1 mm
- Meter weight Around 127.3 g
- Telltales  
  - Ⓛ High beam (Blue)
  - Ⓝ Neutral (Green)
  - Ⓞ Oil (Red)
  - Ⓢ RPM shift light (Yellow / Red)
  - Ⓤ Temperature alarm (Red)
  - ↔ Repeater (Green)
  - Ⓞ EOBD (Amber)
  - Ⓢ Speeding warning (Red)



### LED TELLTALES METER

Unlike the indicator light kit in the market, the new indicator light kit comes with different telltale symbols, so you could assemble it according to your own demands. There is no need to force yourself to fit some kit doesn't match your bike any more.

NEW!

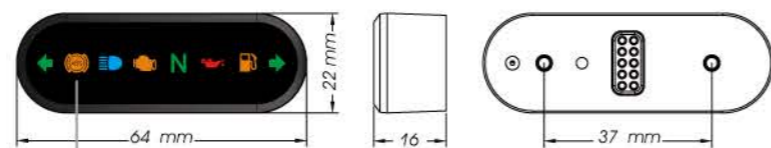

**Indicator**

- Left indication light (Green)
- ABS light (Amber)
- High beam light (Blue)
- Engine light (Amber)
- Neutral light (Green)
- Motor oil light (Red)
- Low fuel warning light (Amber)
- Right indication light (Green)



Item number



## RX1NR+

Most of the tachometers designed for race is digital, and many racers really want to have a big tachometer works in needle for them to check the RPM easily during the race. Now KOSO bring you the new race RX1NR+ with the 64 mm needle tachometer driven by the stepper motor with real time respond, and a temperature meter for you to check the engine situation during the race.

With the shift light and max record function, you could get all the information you need for race.

Get the new RX1NR to monitor your engine, and enjoy the race.

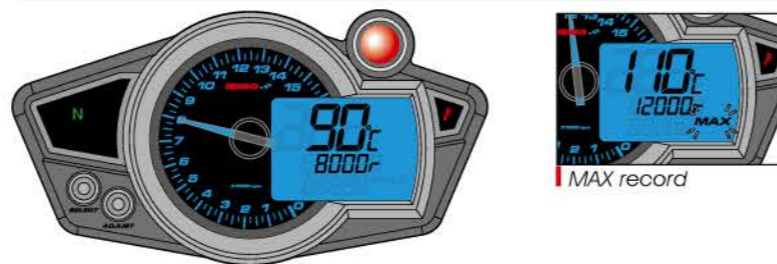

- Tachometer Display range: 0~16,000 RPM
- Digital Tachometer Display range: 0~16,000 RPM ; Display unit: 100 RPM
- Shift light (Red / Yellow) Display range: 0~16,000 RPM ; Display unit: 100 RPM
- MAX RPM record Display range: 0~16,000 RPM
- Piston setting Setting range: 0.5, 1, 1.5, 2, 2.5, 3, 4, 5, 6
- The RPM input pulse Setting range: Hi (The positive wave pulse)  
Lo (The negative wave pulse)
- Thermometer Display range: 0~250°C (32~399°F)
- Over heat warning light Setting range: 60~250°C (140~399°F)  
Setting unit: 1°C (°F)
- Backlight color Blue
- Battery type 9V-1604, 6LR61
- Effective temperature range -10~+60°C
- Meter standard JIS D 0203 S2
- Meter size (W X L X H) 151.8 X 81.5 X 52.5 mm
- Meter weight Around 212 g

Item number  
Backlight color: Display range: Panel color



\* B A 0 1 1 1 0 0 \*  
Blue 0~16,000 RPM Black

### Option accessory

- 1 Temp sensor wire set (2.1M)
- 2 Oil temp sensor adapter  
M12 X P1.5 X 15L  
M14 X P1.25 X 15L  
M16 X P1.5 X 15L  
M18 X P1.5 X 15L  
M20 X P1.0 X 15L  
M20 X P1.5 X 15L
- 3 Water temp sensor adapter  
M14  
M16, M18  
M22, M26 mm
- 4 Temp sensor  
M10 X P1.0  
M12 X P1.5  
M14 X P1.25  
M14 X P1.5  
M16 X P1.5 / M18 X P1.5
- 5 Cylinder head temp sensor  
M10  
M14 mm
- 6 Meter bracket (for handle bar)

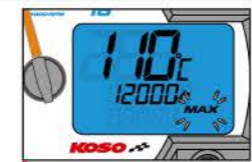
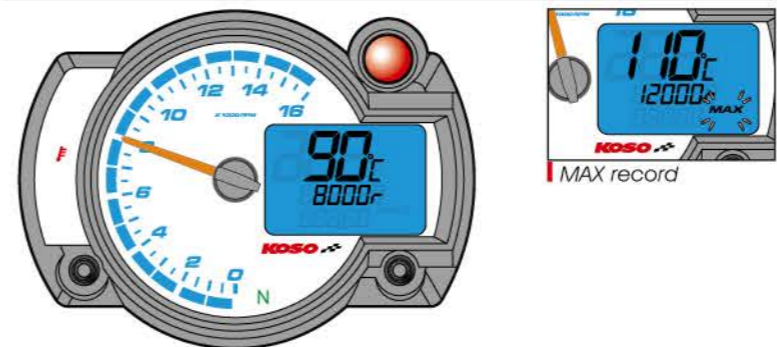

- Tachometer Display range: 0~16,000 RPM
- Digital Tachometer Display range: 0~16,000 RPM ; Display unit: 100 RPM
- Shift light (Red / Yellow) Display range: 0~16,000 RPM ; Display unit: 100 RPM
- MAX RPM record Display range: 0~16,000 RPM
- Piston setting Setting range: 0.5, 1, 1.5, 2, 2.5, 3, 4, 5, 6
- The RPM input pulse Setting range: Hi (The positive wave pulse)  
Lo (The negative wave pulse)
- Thermometer Display range: 0~250°C (32~399°F)
- Over heat warning light Setting range: 60~250°C (140~399°F)  
Setting unit: 1°C (°F)
- Backlight color Blue
- Battery type 9V-12V
- Effective temperature range -10~+60°C
- Meter standard JIS D 0203 S2
- Meter size (W X L X H) 135.7 X 100.7 X 52 mm
- Meter weight Around 240 g

Item number  
Backlight color: Display range: Panel color



\* B A 0 1 5 0 1 0 \*  
Blue 0~16,000 RPM White

### Option accessory

- 1 Temp sensor wire set (2.1M)
- 2 Oil temp sensor adapter  
M12 X P1.5 X 15L  
M14 X P1.25 X 15L  
M16 X P1.5 X 15L  
M18 X P1.5 X 15L  
M20 X P1.0 X 15L  
M20 X P1.5 X 15L
- 3 Water temp sensor adapter  
M14  
M16, M18  
M22, M26 mm
- 4 Temp sensor  
M10 X P1.0  
M12 X P1.5  
M14 X P1.25  
M14 X P1.5  
M16 X P1.5 / M18 X P1.5
- 5 Cylinder head temp sensor  
M10  
M14 mm
- 6 Meter bracket (for handle bar)

## RX2NR+

If the RX1NR+ is still too small for you need please try the RX2NR+. With the 80 mm needle tachometer driven by the stepper motor with real time respond, and a temperature meter, it will be easier for you to check the engine situation during the race. With the settable shift light and max record function, you could get all the information you need for race.

Get the new RX2NR+ to monitor your engine, and enjoy the race.

There are more and more racer practice in the night, so we heard the demand of backlight from the customers. For this reason, we make an upgraded on the RX2NR+ to make the meter comes with the backlight. In this case, it will be easier for the customer to use the meter in the night.





## EGT-02R EVO

The EGT-02R EVO is an evolution of our original dual exhaust temperature meter. This new meter allows you to tune your engine more precisely and keep a record of your previous runs (up to 50). It also includes features such as RPM & water temperature. You will have the ability to set a warning for each setting including water temp, RPM & EGT. The red flashing of the screen makes it very easy to see if something is going wrong with the engine. This tool could save your motor!

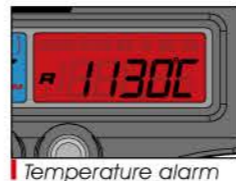

- Temperature Display unit : °C, °F
- EGT L/R Display Range : 100~1,200°C(250~2,100°F)  
Display unit: 1°C (°F)
- Warning for temp (EGT L/R) Setting range : 200~1,000°C(392~1,832°F)  
Setting unit: 1°C (°F)
- Water temperature Display Range : 0~250°C(32~482°F)  
Display unit: 1°C (°F)
- Warning for temp (Water) Setting range : 60~250°C(140~482°F)  
Setting unit: 1°C (°F)
- Tachometer Display Range : 0~15,000 RPM  
Display unit: 10 RPM
- Type of RPM signal Setting range : HIAct ~ LoAct
- RPM input pulse Setting range : P-0.5 ~ P-1 ~ P-1.5 ~ P-2 ~ P-2.5 ~ P-3 ~ P-24
- Warning for RPM Setting range : 5,000~15,000 RPM
- Max. EGT record Display Range : 200~1,000°C(392~1,832°F)  
Display unit: 1°C (°F)
- Max. Water record Display Range : 60~250°C(140~482°F)  
Display unit: 1°C (°F)
- Max. RPM record Display Range : 15,000 RPM  
Display unit: 100 RPM
- Voltmeter Display Range : 0.8~18.0 V
- Warning for low voltage Setting range : 8.0 ~ 13.0 V  
Setting unit: 0.1 V
- Warning for high voltage Setting range : 13.0 ~ 16.0 V  
Setting unit: 0.1 V
- Auto/Manual Record Stop Display Range : 0~60 Sec  
Display unit: 1 Sec
- Backlight brightness Display Range : 1 - 5 (darkest)~ 5 - 5 (brightest)
- Supply voltage DC 12 V
- Temperature range -30~+60°C
- Specifications JIS D 0203
- Meter size W124 X L58.5 X H22 mm
- Meter weight +/- 170 g

Item number Backlight color, Display range Panel color

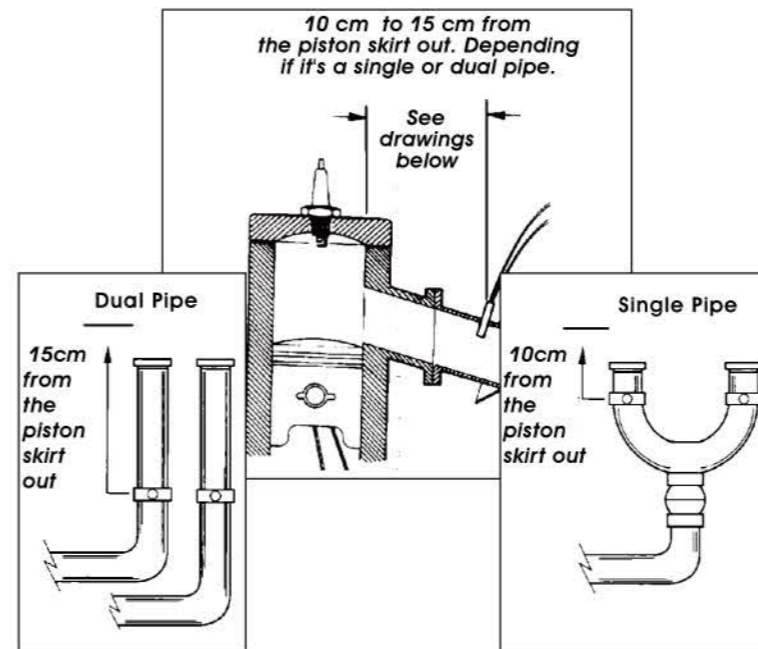

## INSTRUCTIONS

The temperature indicated on your gauge is the temperature at the tip of your exhaust sensor. This temperature is different for each sleds on the market. An engine should never be tune by exhaust temperature alone. The exhaust gas temperatures are a great tuning aid but they are not the final word. The normal temperature range for most sleds will range between 593°C and 676°C depending on the engine set up. The temperature indicated should always be correlated with the piston and plug color. Generally, probe location should be between 10 cm to 15 cm from the piston skirt out. Each sled and exhaust systems manufacturer have their own specifications for probe location and running temperature. To be more precise, these manufacturing companies should be contacted for all the details needed.



## EGT

This nice backlighted Exhaust temperature gauge will give you precious informations on your engine. It will allow you to tune more precisely your engine. Its warning could even save your engine from bad damages !



**Switch °C to °F**  
 ● In main screen, press down the **Select button** to switch °C to °F.

- Temperature Display range: 100~1,200°C (250~2,100°F)  
Display unit: 1°C (°F)
- Temperature alarm Setting range: 200~1,000°C (392~1,832°F)  
Setting unit: 1°C (°F)
- Top temperature record Display range: 100~1,200°C (250~2,100°F)  
Display unit: 1°C (°F), °C & °F for alternative  
<0.5 second
- Display Internal <b>DC 12V</b>
- Effective temperature range -10~+60°C
- Meter standard JIS D 0203 S2
- Meter size (W X L X H) 99.6 X 42 X 22.5 mm
- Meter weight Around 85 g

Item number	Item number
Backlight color: Display range: Panel color	Backlight color: Display range: Panel color



### Option accessory

- 1 EGT sensor (Sport)
- 2 EGT sensor (Race)
- 3 EGT sensor bracket  
40-60 mm  
60-80 mm
- 4 Meter bracket (For handle bar)
- 5 Meter bracket (For handle switch)
- 6 Meter bracket (For handle bar)



- Air / fuel ratio meter Display range: 10.0 ~24.0
- Over lean setting **LEAN** 14.8~24.0
- Over rich setting **RICH** 14.6~10.0
- Display internal <0.5 second
- **Supply voltage DC 12V**
- Effective temperature range -10~+60°C
- Meter standard JIS D 0203 S2
- Meter size (W X L X H) 99.6 X 42 X 22.5 mm
- Meter weight Around 85 g

Item number
Backlight color: Display range: Panel color



### Option accessory

- 1 Sensor adapter (For 2 stroke engine only)

## Wide Band A/F Ratio

This nice backlighted Wideband Air/Fuel Ratio Gauge will give you precious informations on your engine. It will allow you to tune more precisely your engine. Its warning could even save your engine from bad damages ! Its programmable warning will tell if your engine run too lean or too rich. Work on 2 and 4 stroke engines. Require 12V DC power.



**DL-03A**  
A/F & RPM Data Logger

The DL-03A is the newest addition into our lineup of multifunction meters which features air fuel ratio reading, RPM and playback ability to optimize your rides performance. The large digits and bright backlight makes it easy to read at anytime. This meter is also easy to operate, compact and lightweight and can be mounted to many applications including snowmobiles, UTV's and more.



NEW!

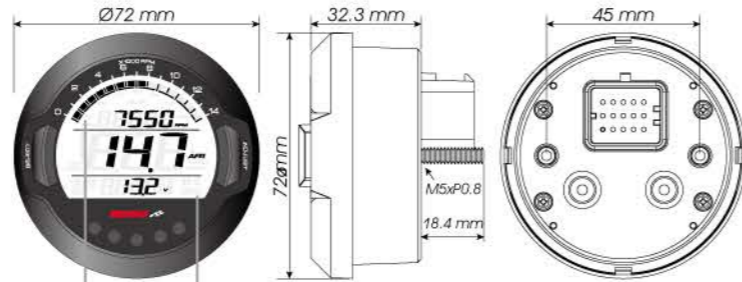

**Tachometer**  
 ● Display Range : 0 ~ 14,000 RPM  
 ● Display unit : 100 RPM  
**Tachometer (Displays in segments)**  
 ● Display Range :  
**Displays in 14 segments (100 RPM each segment) Air-fuel ratio**  
 ● Display Range : 9.0 ~ 24.0  
 ● Display unit : 0.1  
**Air-fuel ratio (Displays in segments)**  
 ● Display Range : Displays in 12 segments

**Play mode Speed**  
 ● 1x play/pause  
 ● 1/3x play/pause  
 ● 3x play/pause  
 ● 1x rewind/pause

Item number	Backlight color	length	Bezel
-------------	-----------------	--------	-------



* B B 6 4 2 W 3 0 *	White	6 foot	Black
* B B 6 4 2 W 3 1 *	White	12 foot	Black

● Tachometer	Display Range : 0 ~ 14,000 RPM Display unit : 100 RPM
● Tachometer (Display in segments)	Display Range : Displays in 14 segments (100 RPM each segments)
● RPM input pulse	Setting range : 0.5 , 1 , 1.5 , 2 , 2.5 , 3 , 4 , 5 , 6 , 7 , 8 , 9 , 10 , 11 , 12 , 13 , 14 , 15 , 16 , 17 , 18 , 19 , 20 , 21 , 22 , 23 , 24
● Type of RPM signal	Setting range : Hi Act, Lo Act Default value : Hi Act
● Warning for RPM	Setting range : 1,000 ~ 14,000 RPM Setting unit : 100 RPM Default value : 8,000 RPM
● Warning for low voltage	Setting range : 8.0 ~ 13.0 V Setting unit : 0.1 V Default value : 11.5 V
● Backlight brightness	Setting range : 1 - 5 (darkest) ~ 5 - 5 (brightest) Default value : 5
● Air-fuel ratio	Display Range : 9.0 ~ 24.0 Setting unit : 0.1
● Warning for Rich air-fuel ratio	Setting range : 9.0 ~ 14.7 Setting unit : 0.1 Default value : 14.4
● Warning for Lean air-fuel ratio	Setting range : 14.7 ~ 24.0 Setting unit : 0.1 Default value : 15.0
● Air-fuel ratio (display segments)	Display Range : Displays in 12 segments
○ Operating voltage	DC 12V
● Temperature range	-10 ~ +60°C
○ Specifications	JIS D 0203(S2)
● Meter Size	72 X 32.3 mm
○ Meter Weight	About 100 g





## RX2NS

Our RX-2NS data logger is the perfect meter for drag and oval racers. Made from the best components and latest technology, it allows the user to playback his runs easily. The 390 minutes internal memory gives the opportunity to record up to 50 runs. Its heated screen will allow the user to play with it even under winter condition. The programmable shift light and piston setting makes it accessible to about any 2 or 4 strokes engine. This makes it a great tool to help find the right clutching or gear ratio.



- Tachometer Display range: 0~11,000 RPM ; Display unit: 100 RPM
- Digital Tachometer Display range: 0~11,000 RPM ; Display unit: 10 RPM
- Shift light Setting range: 100~11,000 RPM ; Setting unit: 100 RPM
- MAX RPM record Display range: 0~11,000 RPM
- Records Number of records: 50 sessions
- Recording Time Duration of recording: 99'59"99  
Total duration of recording: Approx. 6.30 Hours
- Play mode 1x play/pause, 1/3x play/pause  
3x play/pause, 1x rewind/pause
- Effective voltage DC 12V
- Effective temperature range -10~+60°C
- Meter standard JIS D 0203 S2
- Meter size (W X L X H) 135.7 X 100.7 X 52 mm
- Meter weight Around 240 g

Item number  
Backlight color Display range Panel color



White 0~11,000 RPM Black



- Digital air density in % Indicating range: 50~150%, will blink to warn at over-range  
Indicating unit: 1%
- Air density scale in % Indicating range: 70~130%  
Indicating unit: 1%
- Barometric pressure Indicating range: hPa: 500~1150 hPa  
mmHg: 375.0~862.5 mmHg  
inHg: 14.76~33.95 inHg  
Indicating range: hPa: 1 hPa  
mmHg: 0.5 mmHg  
inHg: 0.1 inHg
- Air temperature Indicating range: -20.0~80.0°C (-4.0~176.0°F), will blink to warn at over-range
- Battery remaining capacity Indicating range: 4 - stage indication  
Warning range: will blink to warn the battery power is LOW
- Battery cell CR 2032
- Unit body using temperature range -10~+60°C (14~+140°F)
- Unit body specification JIS D 0203 S2
- Unit body dimension 87.2 X 44.2 X 20.85 mm
- Unit body weight 82g approximately
- Warning Light Warning light will come "ON" if the air density goes 5% higher or lower than the reference point.

Item number  
Backlight color Display range Panel color



White

## Air Density Meter

This is a great tool for serious engine tuners. Our air density meter allows to see if the air density has changed. It could help you determine if the jetting or fuel mapping should be adjusted. Altitude, temperature and atmospheric pressure can affect quickly the performance of the engine. Our meter will instantly tell you if the condition has change so the proper changes can be made on the engine. This is a must for performance enthusiasts since it will help get the extra horsepower out of the engine or it could even save the engine from bad damages.



## EFI Multi Meter

Following customer request, we came up with this useful optional air/fuel ratio function. This instrument has a large graph bar and RPM digits, which makes it very easy to read, even at high speed. The adjustable scale for 10 000, 15 000 or 20 000 RPM allows this meter to adapt to almost any type of engine. Other than its RPM and 2 temperature readings, this meter also features voltage and clock functions. Its programmable shift light and temperature warning lights will help you monitor your engine and make it the perfect racing tool!



### Shift light

- Setting range: 5,000~20,000 RPM.
- Setting unit: 100 RPM.

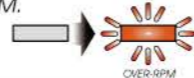

### Volt meter

- Display range: DC 0~15.0 V.
- Display unit: DC 0.1V.



### Clock

- 24H.



### A/F ratio (Option)

- Displayed range: 12.1~16.8.
- Displayed unit: 0.1

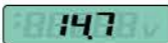

Change



Change



Item number  
Backlight color, Display range, Panel color



★ B A 0 5 2 0 0 1 ★  
White 0~20,000 RPM

### Option accessory

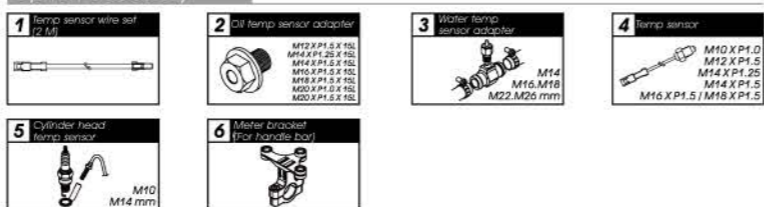

- Digital Tachometer Display range: 0~20,000 RPM  
Display unit: 100 RPM
- Level Tachometer Display range: OFF、0~10,000、15,000、20,000 RPM
- Display internal <0.5 second
- Shift light Setting range: 5,000~20,000 RPM  
Setting unit: 100 RPM
- OMAX RPM record Display range: 0~20,000 RPM
- Stroke / Piston Setting range: 2 Stroke: 1.2.3.4.6 pistons  
4 Stroke: 1.2.4.6.8.10.12 pistons
- Thermometer Display unit: °C & °F for alternative
- Thermometer A/B Display range: 0~250 °C (32~482 °F)  
Display unit: 0.1 °C (°F)
- Display internal <0.5 second
- Thermometer alarm Setting range: 60~250 °C (140~482 °F)  
Setting unit: 1 °C (°F)
- OMAX temperature record Display unit: 0~250 °C (32~248 °F)
- Air/ Fuel ratio Display range: 12.1~16.8  
Display unit: 0.1
- Volt meter (Input power needed, can't work with CR 2032)  
Display range: DC 8.0~18.0 V  
Display unit: DC 0.1 V
- Clock 24 H
- Effective voltage CR 2032 (Lifetime around 2 years)
- External power DC 12 V
- Effective temperature range -10~+60 °C
- Meter standard JIS D 0203 S2
- Meter size 87.5 X 42 X 20.8 mm
- Meter weight Around 72.4 g
- Indicator light color
  - RPM shift light (Red)
  - Temperature A alarm (Blue)
  - Temperature B alarm (Green)



## GPS Lap Timer

Following the popular demand, our crew of engineers have developed a high-tech GPS lap timer to accommodate professional and amateur riders. By using the GPS technology, this lap timer will allow you to get a precise and accurate reading without having to install different beacons around the track. This instrument records up to 200 laps, as well as: speed average speed and many other great functions. Last but not least, this lap timer can also be used as a simple GPS speedometer, due to the speed and odometer functions.

Our GPS lap timer also features a Power-Test function, which allows the user to record time/distance (ex: 1/8 mile, 1/4 mile...) or speed/time (ex: 0-60mph...). This is the perfect tool, whether you are a drag racer, endurance racer or circuit racer. You can finally race like a professional with this multifunctional tool that can be used under many different conditions such as closed and open circuits. Koso's GPS lap timer is simply a must have for all racers!



## Speedometer

- Display range: 0~360 km/h (0~255 MPH)
- Display range: 1 km/h (MPH)

## Riding time

- Record range: 0 ~ 9,999.9 H \* reset automatically after 9,999.9 H
- Record unit: 0.1 H

## Top speed record

- Record range: 0~360 km/h (0~255 MPH)
- Record unit: 1 km/h (MPH)



Change



Change



Item number  
Backlight color: Display range Panel color



\* B A 0 4 5 1 0 0 \*  
White 0~360 km/h

● Speedometer	Display range: 0~360 km/h (0~255 MPH) Display range: 1 km/h (MPH)
○ Odometer	Display range: 0 ~ 99,999 km (mile) * reset automatically after 99,999 km (mile)
○ Trip meter	Display range: 1 km/h (MPH) Display range: 0 ~ 9,999.9 km (mile) * reset automatically after 9,999.9 km (mile) (delete average speed and run time records simultaneously) (delete average speed and run time records simultaneously) Display range: 0.1 km/h (MPH)
○ AVE Speed	Record range: 0~360 km/h (0~255 MPH) Record unit: 1 km/h (MPH)
○ Riding time	Record range: 0 ~ 9,999.9 H * reset automatically after 9,999.9 H Record unit: 0.1 H
○ Top speed record	Record range: 0~360 km/h (0~255 MPH) Record unit: 1 km/h (MPH)
● Geodetic coordinate system	WGS-84
○ Coordinate display method	Setting range: d°m' s.s" · d. d° · d°m.m
● Time zone	Setting range: UTC-12:00 ~ +14:00
● Calendar	Automatic Time Adjustment by GPS signal
● Clock	Setting range: 12 · 24 H Automatically set clock according to time zone selected.
● Voltage warning	Battery symbol flashes when voltage is lower than the 7.0V
● Display contrast adjustment	Setting range: 1~16 level
● Backlight brightness adjust	Setting range: 0 (Close) ~ 1 (Darkest) ~ 7 (Brightest). The backlight brightness will change immediately after you set the value.
○ Single recording time	Record range: 00'00"00~99'59"99
○ Number of loop record	Record range: 1~200 Laps (Maximum)
○ Time difference compares to the best time record	Display range: 00'00"~99'99"
○ Time difference compares to last loop	Display range: -99'99"~+99'99"
○ Record display method	Setting range: Sequentially · Best
○ Record displays retention time	Setting range: 5~20 second
● Target speed timer	Setting range: 30~360 km/h (20~255 MPH) Setting unit: 5 km/h (MPH)
● Target distance timer	Setting range: 1/32~30/32 mile (50~1,500 M) Setting unit: 1/32 mile (50 M)
● Closed track single loop time recording	Setting range: 0'00"00~9'59"99
● Open track single loop time recording	Setting range: 0'00"00~9'59"99
● Create track	Setting range: close, open
○ Track width	Setting range: 5~50 M Setting unit: 1 M
○ Track length	Auto-calculation after travel a loop
○ Checkpoint	Checkpoint Setting range: 0~22 points (Max.)
● Effective voltage	DC 12 V
● Effective temperature range	-10 ~ +60 °C
● Meter standard	JIS D 0203 S2
● Meter size	107.7 X 61.7 X 20.5 mm
● Meter weight	Around 132.2 g



## RPM Data Logger

Our digital ROM data logger is the perfect meter for drag and oval racers. It is built from the best components and latest technology, such as, an LCM screen. The internal memory lasts up to 76 minute and allows you to record up to 99 runs. Users can easily playback the data by choosing a Graph bar or Numeric display. Since it has programmable settings it is accessible to practically every 2 or 4 strokes engine. Equipped with a volt meter, adjustable backlight and adjustable resolution, this meter is the ideal tool to help set-up the right clutching or gear ratio.



Change



Change



- Tachometer Display range : 0~20,000 RPM  
Display unit : 10 RPM
- The RPM input signal number setting Setting unit : 0.5~4
- Logger function Display range : 99 Data  
Maximum recordable time : Around 76 minute
- Record display Display range : 0~20,000 RPM
- Resolution Setting range : 16 levels  
Setting unit : 1(Dark)~16(Bright)
- Backlight Setting range : 8 levels  
Setting unit : 0(Extinction) 、 1(Dark)~7(Bright)
- Volt Display range : DC7~18V
- Effective temperature range -10~60°C
- Meter standard JIS D 0203 S2
- Meter size 107.7 X 61.7 X 20.5 mm
- Meter weight Around 132.2g

Item number  
Backlight color: Display range: Panel color



\* B A 0 4 5 0 0 0 \*  
White 0~20,000 RPM



- Tachometer Display range: 0~20,000 RPM  
Display unit: 100 RPM
- Display internal <0.5 second
- Max. RPM record Display range: 0~20,000 RPM  
Display unit: 1 RPM
- Total hour meter Display range: 99,999 (HOUR), reset automatically after 99,999 (HOUR)  
Display unit: 1 HOUR
- Hour meter A / B Display range: 9999.9 (HOUR), reset automatically after 9999.9 (HOUR)  
Display unit: 0.1 HOUR
- RPM input pulse Setting range: 0.5, 1~6
- Warning Setting range: 5,000~20,000 RPM  
Setting unit: 100 RPM
- Thermometer Display unit: °C & °F for alternative
- Thermometer Display range: 0~250°C (32~482°F)  
Display unit 0.1°C (°F)
- MAX temperature record Display range 0~250°C (32~482°F)
- Thermometer alarm Setting range 60~250°C (140~482°F)  
Setting unit 0.1°C (°F)
- Backlight brightness Setting range 1-5 (Darkest)~5-5 (Brightest)  
Setting unit Each level represents 20%
- Effective voltage CR 2032 Lifetime around 10 mont
- Effective temperature range -10~+60 °C
- Meter standard JIS D 0203 S2

Item number  
Backlight color: Display range: Panel color



\* B A 0 5 4 0 0 0 \*  
White 0~360 km/h

## PRO-1

The small rev. counter is designed for the race, so we try to make it very small and work on the inner battery. There are tachometer, thermometer, the engine running hour, MAX record, and the RPM & temperature alarm functions including in the rev. counter, so you could get almost all the basic function you need for the race with it. If you want to use the meter on your bike every day, you could also connect the Backlight power to your battery and enable the Backlight function.



## Performance Logger

Excellent portable Dyno tool for all bike lover, to measure and understand your bike's performance any time and anywhere. New designed user interface to be easier to get your horse power reading in a minute, also switchable display method you could choose from either seeing digit or curve. This new generation of gauge could allow you adjust the backlight brightness and the LCD contrast to make sure you can see the reading clearly in all circumstance, not to mention it come with multiple method of warning, shift light and warning range setup to secure your bike during the test. The gauge could save up to 49 testing curves data for you to check what is the best tuning condition of your bike!

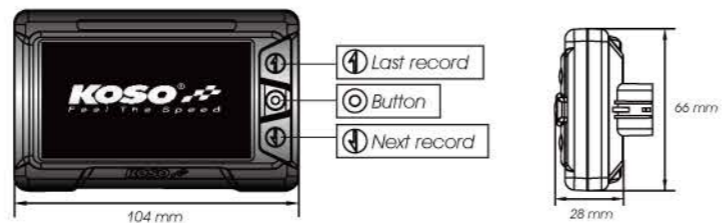

- Speedometer Display range : 0~360 km/h (0~223 MPH)  
Display unit : 1 km/h (MPH)  
(may shift between km and mph)
- Circumference Setting range : 300~2500 mm  
Setting unit : 1 mm
- Sensing point Setting range : 1~60 P  
Setting unit : 1P
- Tachometer Display range : 0~20000 RPM  
Display unit : 100 RPM
- The RPM input signal number setting Setting range : 0.5, 1.0
- Logger function Display range : 50 Data  
Display record : Curves, figures
- Rider weight Setting range : 40~150 kg  
Setting unit : 1 kg
- Motor weight Setting range : 40~199 kg  
Setting unit : 1 kg
- Back light brightness Setting range : 0(Extinction), 1(Dark) ~ 7(Bright)  
Setting unit : 1
- Resolution Setting range : 1~15  
Setting unit : 1
- Indicator Setting range : Full bright, quick flashing,  
slow flashing, off
- Operating temperature -10~60°C
- Specification JIS D 0203(S2)
- Meter Size About 104 x 28 x 66 mm
- Meter Weight Around 115 g

Item number  
Backlight color: Display range: Panel color



\* B A 0 6 6 1 0 0 \*  
White 0~360 km black



- Gear meter Display range: N, 1, 2, 3, 4, 5, 6, 7
- Supply voltage DC 12 V
- Effective temperature range -10~+60°C (14~140°F)
- Meter standard JIS D 0203
- Meter size (W X L X H) 37 X 51 X 17mm
- Meter weight Around 51.3 g

Item number  
Backlight color: Display range: Panel color



\* K N 0 0 2 0 0 0 \*   \* K N 0 0 2 0 0 1 \*   \* K N 0 0 2 0 1 0 \*  
Blue Universal Black   Blue MSX/GROM Black   Blue Harley Davidson Black

## GEAR METER

Always wondering in which gear you're in? Avoid this question by using our gear indicator. Lightweight, compact, easy to use and to install, this meter will tell you quickly which gear you've selected. Its big digits and blue backlight makes it easy to read during day or night riding. This meter is a great addition for the serious riders.



## GPS POWER TEST BOX

PowerTry is a powerful and affordable vehicle performance measurement tool that uses high-performance satellite positioning chips combined with low-energy Bluetooth transmission for data exchange and control with mobile phones. PowerTry provides high-precision 18Hz satellite positioning data, and through data filtering and estimation algorithms, reduces the measurement time error of straight-line acceleration to within 100 milliseconds, making it a convenient performance measurement tool. K Race and K Lap apps provide systematic data analysis and display.

NEW!

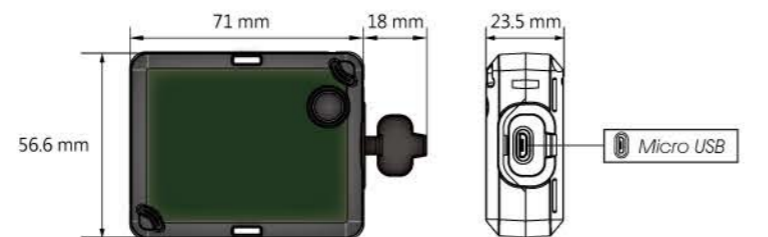

- USB Charging Voltage DC 5 V
- Effective temperature range -10~60°C
- IP Level IP54
- Size 71 X 56.6 X 23.5 mm
- Weight About 75.5 g



**K Race**  
for iOS & Android

K Race is a data monitoring tool that helps drivers of cars and motorcycles adjust their vehicles. By connecting to the KOSO Powertry device via Bluetooth, it can efficiently monitor vehicle data. Because the KOSO Powertry device has a highly efficient GPS and gyroscope module built in, it can record data at a high frequency interval, providing very precise and effective values. Compared to other apps that only use phone GPS data, its data is much more accurate.



● Utilities for performance tuning.



● Segmented data analyzation.



● Historical exam records comparison.



● Multi-faceted data monitor.

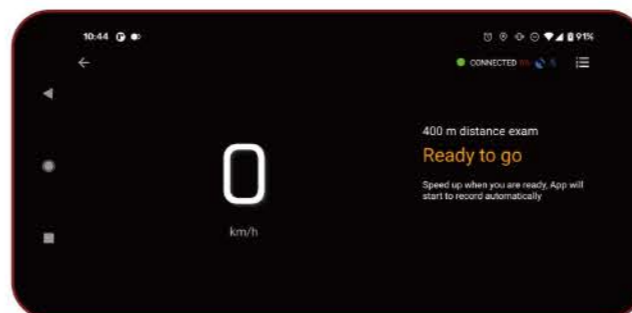

● Touch-free during exams.



Scan the QR code to connect the video

# Race

## Mini style

### MINI 3 HEAD THERMOMETER

Need to monitor your engine temperature? Our Mini 3 meter is designed especially for Honda Grom which is the perfect addition for you. It's peak recall function will allow you to see the maximum temperature reach.



#### Max. temperature record

- Displayed range: t-1 - -20~200°C (-4~392°F)
- t-2 - -40~185°C (-40~365°F)
- t-3 - -20~220°C (-4~428°F)
- t-4 - -20~200°C (-4~392°F)
- t-5 - -20~120°C (-4~248°F)



- Temperature Display range: t-1 - -20~200°C (-4~392°F)
- t-2 - -40~185°C (-40~365°F)
- t-3 - -20~220°C (-4~428°F)
- t-4 - -20~200°C (-4~392°F)
- t-5 - -20~120°C (-4~248°F)

- Temperature type Display unit: t-1~t-5
- Effective voltage DC 12V
- Effective temperature range -10~+60°C
- Meter standard JIS D 0203 S2
- Meter size (W X L X H) 60 X 30 X 11.5 mm
- Meter weight Around 22g



#### Item number

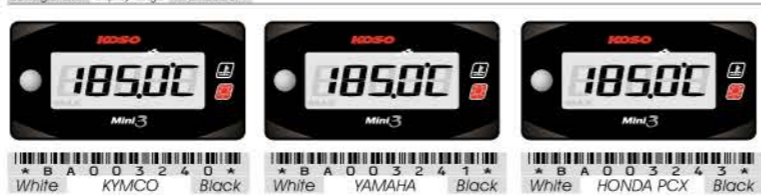

#### Thermometer A, B

- 0~120°C (32~248°F)



- Thermometer A, B Display range : 0~120°C [32~248°F]
- Display unit : 0.1°C(°F)
- Effective voltage DC 12 V
- Effective temperature range -10~+60°C
- Meter standard JIS D 0203 S2
- Meter size (W X L X H) 60 X 30 X 11.5 mm
- Meter weight Around 22 g

#### Item number

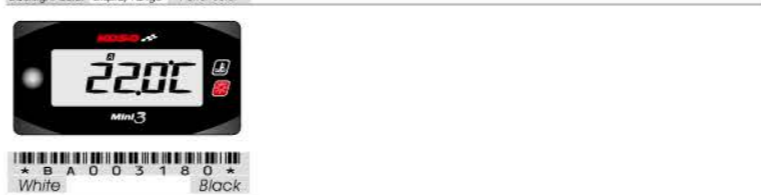

#### Option accessory

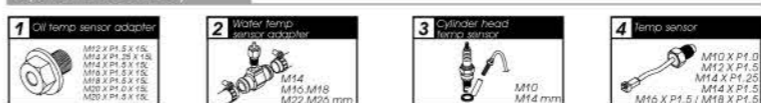

## Mini style

### MINI 3 DUAL TEMPERATURE

The Mini3 meter comes with 2 temperature function, so you could install the sensors at the place you want to check and get the temperature information easily. For example, you could install one sensor at the entrance and exit of the cooling system, and the you could know if the cooling system work properly. The dual temperature meter is the best tool for you to check the temperature.



# Race

## Mini style

### MINI 3 OIL PRESSURE

Our Mini Style oil pressure gauge is a must for all applications. Its reading can help you avoid major mechanical problems. If the pressure goes down, that can indicate a leak in the system or a malfunction of the engine. Also, if you ride your bike at a high RPM range, the pressure meter can help you understand if the oil lubricates the engine properly. Small, compact, lightweight and using a wider screen than similar sizes meter, this gauge is a perfect complement to your actual cluster!



LCD mark on the upper position represents the current unit is **PSI**



LCD mark on the lower position represents the current unit is **kgf/cm<sup>2</sup>**



- Oil pressure meter      Display range: 0.0~100.0PSI (0.0 ~ 7.0 kgf/cm<sup>2</sup>)  
Display unit: 0.1PS (kgf/cm<sup>2</sup>).
- Oil pressure warning      Warning Range: When pressure below the setting value (included), the LCD display will flash to warn.
- Effective voltage      DC 12V
- Effective temperature range      -10~+60°C
- Meter standard      JIS D 0203 S2
- Meter size (W X L X H)      60 X 30 X 11.5 mm
- Meter weight      Around 22g



Item number  
Backlight color, Display range, Panel color



\* B A 0 0 3 2 0 0 \*

White      Black

Option accessory



Amp meter  
● 0~±30 A

15.8A

Volt meter  
● DC 6.0~19.9 V

12.3V

- Amp meter      Display range: 0~±30 A~248°F  
Display unit: 0.1 A
- Volt meter      Display range: DC 6.0~19.9 V  
Setting unit: 0.1 V
- Low Voltage warning      Setting range: DC 8.0~13.0 V  
Setting unit: 0.1 V
- Voltage warning      When the voltage is below DC 11.5 V or over 15.5 V, the LCD display will flash to warn.  
DC 12V
- Effective voltage      DC 12V
- Effective temperature range      -10~+60°C
- Meter standard      JIS D 0203 S2
- Meter size (W X L X H)      60 X 30 X 11.5 mm
- Meter weight      Around 22 g

Item number  
Backlight color, Display range, Panel color



\* B A 0 0 3 1 9 0 \*

White      Black

## Mini style

### MINI 3 AMP & VOLT

The mini 3 series as been developed with the best components and latest technology. This compact and lightweight instrument will give you the vehicle voltage and amps used. This meter can be very helpful especially when there is many electrical accessories connected to the vehicle.





# Race

## Mini style

### MINI 3 AIR / FUEL RATIO

Our new Mini 3 air/fuel ratio gauge was especially designed to help you tune your carbureted or fuel injected engine. This meter can be easily installed on any type of 4 stroke engine by installing the sensor in the exhaust system and connecting the instrument to a 12 v DC source of power.



The A/F ratio is too rich

-R-

The A/F ratio is too lean

-L-

●A/F ratio	Display range: 12.2~17.2
	Setting unit : 0.1
●Effective voltage	DC 12V
●Effective temperature range	-10~+60°C
●Meter standard	JIS D 0203 S2
●Meter size (W X L X H)	60 X 30 X 11.5 mm
●Meter weight	Around 22g



Item number  
Backlight color, Display range, Panel color



Barcode  
White Black

Option accessory

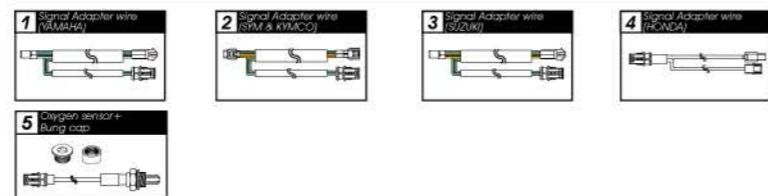

Thermometer

●0~120°C (32~248°F)

22.0°C 73.0°F

●Thermometer	Display range : -22~248 °F (-30~120 °C)
	Display unit : 0.1°F (°C)
●Effective voltage	DC 12 V
●Effective temperature range	-4~+140 °F (-20~60 °C)
●Meter standard	JIS D 0203 S2
●Meter size (W X L X H)	60 X 30 X 11.5 mm
●Meter weight	Around 22 g

Item number  
Backlight color, Display range, Panel color



Barcode  
White Black

## Mini style

### MINI 3 AMBIENT TEMPERATURE

The Mini3 meter comes with 2 temperature function, so you could install the sensors at the place you want to check and get the temperature information easily. For example, you could install one sensor at the entrance and exit of the cooling system, and then you could know if the cooling system work properly. The dual temperature meter is the best tool for you to check the temperature.



# Race

## Mini style

### MINI 3 CLOCK & VOLT

The mini 3 series as been developed with the best components and latest technology. This compact and lightweight instrument features a clock and also the vehicle voltage. This meter can be very helpful especially when there is many electrical accessories connected to the vehicle.



<b>Clock</b> ●24H 12:00	<b>Volt meter</b> ●DC 6.0~19.9 V 12.5
-------------------------------	---------------------------------------------

●Volt	Display range: DC 6.0~19.9 V
	Setting unit : 0.1
●Effective voltage	DC 12V
●Effective temperature range	-10~+60°C
●Meter standard	JIS D 0203 S2
●Meter size (W X L X H)	60 X 30 X 11.5 mm
●Meter weight	Around 22g



096 / 097

Item number  
Backlight color, Display range, Panel color



White Black



<b>Clock</b> ●24H 12:00
-------------------------------

●Thermometer	Display range : -22~248 °F (-30~120 °C)
	Display unit : 0.1°F ( °C)
●Effective voltage	DC 12 V
●Effective temperature range	-4~+140 °F (-20~60 °C)
●Meter standard	JIS D 0203 S2
●Meter size (W X L X H)	60 X 30 X 11.5 mm
●Meter weight	Around 22 g

Item number  
Backlight color, Display range, Panel color



White Black

## Mini style

### MINI 3 CLOCK METER

The all new MINI3 Clock meter could provide you the easier way to get the most watched information when you are riding! The meter is so compact that you could place in any place of your bike with easy connection. You don't need to take your hands off the grip to take a look of your watch and leave your sight from the road anymore, with a glance you will know the time for now!



Race 2024

Race Mini style

MINI 3 CLOCK & VOLT / CLOCK METER

# Race

## Mini style

### MINI 3 FUEL METER

Changed your cluster and need to monitor your fuel level? Our Mini 3 fuel meter will give you that precious information. Compact, lightweight and easy to connect to your OEM fuel sensor; the Mini 3 fuel meter is a must have!

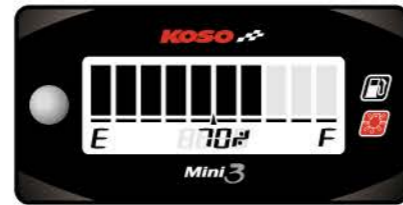

#### Fuel setting range

- 100Ω, 180Ω, 250Ω, 270Ω, 510Ω, 700Ω, 1200Ω



● Fuel level	Display range: 10 levels (0~100%)
● Digital Fuel	Display range: 0~100% Display unit: 1% Setting range: 100Ω, 180Ω, 250Ω, 270Ω, 510Ω, 700Ω, 1200Ω, USER
● Fuel warning	Setting range: 0~25% Setting unit: 1%
● Effective voltage	DC 12V
● Effective temperature	-10~+60°C
● Meter standard	JIS D 0203 S2
● Meter size (W X L X H)	60 X 30 X 11.5 mm
● Meter weight	Around 22g



Item number  
Backlight color, Display range, Panel color



\* B A 0 0 3 2 5 0 \*

White Black



● Temperature	Display range: -4.0~302.0°F, Display unit: 0.1°F
● Temperature warning	Setting range: 140~302°F, Setting unit: 1°F
● Volt meter	Display range: 8.0v~18.0v, Display unit: 0.1 v
● Effective voltage	DC 12V
● Effective temperature range	-10~60 °C
● Water-Proof Standard	JIS D 0203
● Meter size	W69.8 X L34.4 X H17.2 mm
● Meter weight	About 47.5 g

Item number  
Backlight color, Display range, Panel color



\* B A 0 3 3 0 5 0 \*

White Black

## Mini style

### MINI 4 INFRARED TEMPERATURE

The mini4 meter comes infrared temperature, so you could install the sensors at the place you want to check and get the temperature information easily. Its small and compact size makes it very easy to install at almost any location on the bike.



## MINI 4 ENGINE HOURMETER

How do you know the time to replace the parts or change the oil for your dirt bike or sport ATV when they come without the speedometer? Most of the people do it by feeling or experience before, but now you don't need to guess any more. KOSO provide you the new tool for doing this job for you, so you don't need to keep it on Your mind all the time. All you need to do is to check the hour meter.



### Hour meter A/B

- Display range: 0.0~999.9 H
- Display unit: 0.1 H



● Total hour meter	Display range: 0~99999 ; Display unit: 1 H
● Hour meter A/B	Display range: 0.0~999.9 H ; Display unit: 0.1 H
● Effective voltage	DC 12V
● Battery type	CR 2032
● Battery life time	About 350 H (when battery volume below 250 mAh)
● Effective temperature range	-10~+60°C
● Meter standard	JIS D 0203
● Meter size (W X L X H)	69.8 X 34.4 X 17.2 mm
● Meter weight	Around 47.6g



Item number  
Backlight color, Display range, Panel color



White Black



### Thermometer A. B

- -25°C~250°C (-13°F~482°F)

### MAX Temp. record



● Thermometer A, B	Display range: -25°C~250°C (-13°F~482°F) Display unit: 0.1°C (°F)
○ Temperature Warning	Range: Settable temperature warning range. Display will flash when the temperature is higher than (or equals to) the setting value.
● Battery type	CR 2032
● Battery life time	About 230 H (when battery volume below 250 mAh)
● Effective temperature range	-10~+60°C
● Meter standard	JIS D 0203
● Meter size	W69.8 X L34.4 X H17.2 mm
● Meter weight	Around 47.6g

Item number  
Backlight color, Display range, Panel color



White Black

## MINI 4 DUAL TEMPERATURE

Have you ever feel lost and have no clue when and why your bike get overheat engine all the time? This special protable dual temperature compact meter will easily solve your problem by just install it on your bike, also the meter allows to use inner battery to work so you don't need to connect the power supply or makes it more easily to switch the meter between different bike. The KOSO Mini 4 Dual Temperature meter allows you to know your coolant temperature by install the 2 sensors at 2 different position of your cooling system - IN/OUT then you will easier know if your cooling system is working properly or not by visual observation.



# Race

## Mini style

### MINI 4 A/F RATIO METER

Have you ever find it difficult to understand the A/F ratio from your bikes? Especially when you have more than 2 bikes and lack of instrument to observe the information you want? This all new protable KOSO Mini 4 A/F ratio will be your final solution! With inner battery to allow you don't have to connect the power supply of the bike so makes it more easier to switch from one bike to another. Of course, you also can connect the power supply and leave it on one bike because the size of the meter is so compact and you could place it in any where you like and easily to get the A/F information you want in anytime when you ride.



The A/ F ratio is too rich  
-R-

The A/ F ratio is too lean  
-L-

●A/F ratio	Display range: 12.2~17.2 Setting unit : 0.1
●Effective voltage	DC 12V
●Battery type	CR 2032
●Battery life time	About 450 H (when battery volume below 250 mAh)
●Effective temperature range	-10~+60°C
●Meter standard	JIS D 0203
●Meter size (W X L X H)	69.8 X 34.4 X 17.2 mm
●Meter weight	Around 47.6g



Item number  
Backlight color / Display range / Panel color



White Black



#### MAX RPM record

- Display range: 0~15,000 RPM
- Display unit: 10 RPM



●Digital Tachometer	Display range: 0~15,000 RPM Display unit: 10 RPM
ODisplay Internal	<0.5 second
ORPM input pulse	Display range: 0.5, 1, 1.5, 2, 2.5, 3, 4, 5, 6
●Effective voltage	DC 12V
●Battery type	CR 2032
●Battery life time	About 350 H (when battery volume below 250 mAh)
●Effective temperature range	-10~+60°C
●Meter standard	JIS D 0203
●Meter size (W X L X H)	69.8 X 34.4 X 17.2 mm
●Meter weight	Around 47.6g

Item number  
Backlight color / Display range / Panel color



White Black

## Mini style

### MINI 4 RPM METER

The style and new design of mini-series meter. Always show the live engine rpm. The white back light could bring you excellent vision in the night. The meter could work by the small battery inside(CR2032). Perfect for the motocross or the bikes without battery.



## Race

### Mini style

## MINI 4 RPM & HOUR METER

The new Mini4 meter comes with the new shape design makes the meter look more stylish. Except the shape design, the new meter comes with the new battery socket design to upgrade the anti-vibration level and the new structure allows you to choose to use the Velcro to stick the meter on your bike or using the screw to fix the meter. The meter works with the inner CR2032 battery, so you could use the meter on the off road bikes or ATV which come without the battery. With the engine hour function, it will be very easy for you understand how long the engine already run and when you need to do the maintain. The best tool to monitor the engine!



#### MAX RPM record

- Display range: 0~15,000 RPM
- Display unit: 10 RPM



● Digital Tachometer	Display range: 0~15,000 RPM Display unit: 10 RPM
○ Display interval	<0.5 second
○ RPM input pulse	Display range: 0.5, 1, 1.5, 2, 2.5, 3, 4, 5, 6
● Total hour meter	Display range: 0~99999; Display unit: 1 H
● Hour meter A/B	Display range: 0.0~999.9 H; Display unit: 0.1 H
● Effective voltage	DC 12V
● Battery type	CR 2032
● Battery life time	About 350 H (when battery volume below 250 mAh)
● Effective temperature range	-10~+60°C
● Meter standard	JIS D 0203
● Meter size (W X L X H)	69.8 X 34.4 X 17.2 mm
● Meter weight	Around 47.6g

Item number  
Backlight color: Display range: Panel color:



\* B A 0 3 3 W 0 \*

White Black



#### Volt meter

- Display range: DC 8.0~18.0 V
- Display unit: 0.1 V

#### Voltage warning

- When the voltage is lower than 11.5V, the meter will flash to warn you.



● Volt meter	Display range: DC 8.0~18.0 V Display unit: 0.1 V
○ Voltage warning	When the voltage is lower than 11.5V, the meter will flash to warn you.
● Effective voltage	DC 12V
● Effective temperature range	-10~+60°C
● Meter standard	JIS D 0203 S2
● Meter size	56.4 X 27 X 11 mm
● Meter weight	Around 20 g

Item number  
Backlight color: Display range: Panel color:



\* B A 0 2 4 B 0 \*

Blue Black Red Black

### Super slim style

## VOLT

Our super slim series is probably one of our best seller. Its small and compact size makes it very easy to install at almost any location on the bike. The blue illuminated digits make the meter very attractive and easy to read at night. Our super slim volt meter is equipped with a warning function to help you monitor the voltage. The meter will automatically flash if the voltage goes below than 11.5 volts.



## Race

Super slim style

### THERMOMETER

Our super slim series is probably one of our best seller. Its small and compact size makes it very easy to install at almost any location on the bike. The blue illuminated digits make the meter very attractive and easy to read at night. Our super slim temperature meter is equipped with a warning function to help you monitor the engine temperature. The meter will automatically flash if the temperature goes higher than 120°C.



#### Thermometer

- Display range : 0~120°C
- Display unit : 1°C

#### Temperature Warning

○ When the temperature is over 120°C., the meter will flash to warn you.



● Thermometer	Display range : 0~120°C (32~248°F) Display unit : 1°C (°F)
○ Temperature Warning	When the temperature is over 120°C (248°F), the meter will flash to warn you.
● Effective voltage	DC 12V
● Effective temperature range	-10~+60°C
● Meter standard	JIS D 0203 S2
● Meter size	56.4 X 27 X 11 mm
● Meter weight	Around 22 g



Item number  
Backlight color / Display range / Panel color



\* B A 0 2 4 B 1 0 \*  
Blue 0~120°C Black



\* B A 0 2 4 B 1 1 \*  
Blue 32~248°F Black



\* B A 0 2 4 R 1 1 \*  
Red 0~120°C Black



\* B A 0 2 4 R 1 0 \*  
Red 32~248°F Black



#### Clock

- 24H



● Clock	24H
● Effective voltage	DC 12V
● Effective temperature range	-10~+60°C (14~140°F)
● Meter standard	JIS D 0203 S2
● Meter size	56.4 X 27 X 11 mm
● Meter weight	Around 22 g

Super slim style

### CLOCK

We now provide with only clock in our super slim meter line up. You don't want to wear the watch when you are on the racetrack, but you still want to know the time exactly? Try this and you won't be disappointed.



Item number  
Backlight color / Display range / Panel color



\* B A 0 2 4 B 2 0 \*  
Blue Black

## Race

### Super slim style

#### CLOCK & VOLT

Our super slim series is probably one of our best seller. Its small and compact size makes it very easy to install at almost any location on the bike. The blue illuminated digits make the meter very attractive and easy to read at night. Our super slim clock & volt meter is a convenient tool. Simply press the button to switch between the 2 functions. Our super slim volt meter & clock is equipped with a warning function to help you monitor the voltage. The meter will automatically flash if the volta.

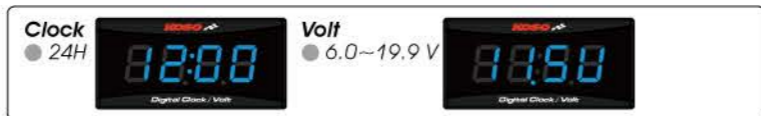

● Clock	24H
● Volt meter	Display range: 6.0~19.9 V ; Display unit: 0.1 V
○ Volt warning setting	Setting range: 8.0~16.0 V ; Setting unit: 0.1 V ON-turn on ; OFF-turn off
○ Default value for voltage warning	High voltage warning: 14.0 V Low voltage warning: 11.0 V
● Effective voltage	DC 12V
● Effective temperature range	-10~+60°C (14~140°F)
● Meter standard	JIS D 0203 S2
● Meter size	56.4 X 27 X 11 mm
● Meter weight	Around 22 g



Item number  
Backlight color Display range Panel color



\* B A 0 2 4 B 5 0 \*  
Blue 24H / 6~19.9 V Black

### NEW !



● Temperature	Display range : -20.0 ~ 120.0 °C (-4.0~248.0 °F) Display unit : 0.1 °C (0.1 °F)
○ Max. temperature record	Display range : 0 ~ 120.0 °C (32.0~248.0 °F) Display unit : 0.1 °C (0.1 °F)
○ Overheat warning	Setting range : 50~120 °C (122~248 °F) Setting unit : 1 °C (1 °F)
○ Voltmeter	Display range : 8.0 v~18.0 v Display unit : 0.1 v
● Low voltage warning	Setting range : 8.0 v~13.0 v
○ Effective temp range	-10~60 °C
● Water-Proof Standard	JIS D 0203
● Meter size	L57.2 X W29.0 X H9.8 mm
● Meter weight	About 26.0 g

Item number  
Backlight color Display range Panel color



\* B A 0 6 8 0 4 0 \* Blue  
\* B A 0 6 8 0 4 1 \* Red  
\* B A 0 6 8 0 4 2 \* Green

### Super slim style-Touch

#### TEMPERATURE & VOLT

New generation of Super Slim LED Meter, with amazing touchscreen feature to allow you switch different reading display by simply touch the screen corner! It comes with indication to tell you if the touchscreen function is activated, not to mention the auto lock feature to prevent any accidental touch. Another benefit for the touchscreen feature is to do as button but without extra button! So your favorite Super Slim LED Meter now is upgraded to a whole new level, which can set the warning for low voltage and high temperature. Slim thickness could let you stick on anywhere of the bike wherever easy to read for the rider; now, except original blue and red, it also comes with green color display!





## Race

i-GEAR style

### i-GEAR VOLT METER

The small and compact size of the i-Gear meters makes it very easy to install at almost any location on the bike. The blue or red illuminated digits make these meters very attractive and easy to read at night.

Different models are available: temperature meters, and volt meter. They are equipped with a warning function to help you monitor the information.

NEW!



● Meter	Display range : DC 7.0 ~ 19.9 V Display unit : 0.1 V
○ Voltage warning	When the voltage is lower than 12 V, the meter will flash to warn you.
● Effective voltage	DC 12 V
● Effective temperature range	-10 ~ +60°C
● Meter standard	JIS D 0203 S2
● Meter size	Ø40 x 11 mm
● Meter weight	Around 24 g

NEW!



● Meter	Display range : 0 ~ 120 °C / 32 ~ 248 °F Display unit : 1 °C / 1 °F
○ Temp. warning	When the temperature is over 120 °C / 248 °F, the meter will flash to warn you.
● Effective voltage	DC 12 V
● Effective temperature range	-10 ~ +60 °C
● Meter standard	JIS D 0203 S2
● Meter size	Ø 40 x 11 mm
● Meter weight	Around 30 g

i-GEAR style

### i-GEAR TEMPERATURE METER

The small and compact size of the i-Gear meters makes it very easy to install at almost any location on the bike. The blue or red illuminated digits make these meters very attractive and easy to read at night.

Different models are available: temperature meters, and volt meter. They are equipped with a warning function to help you monitor the information.

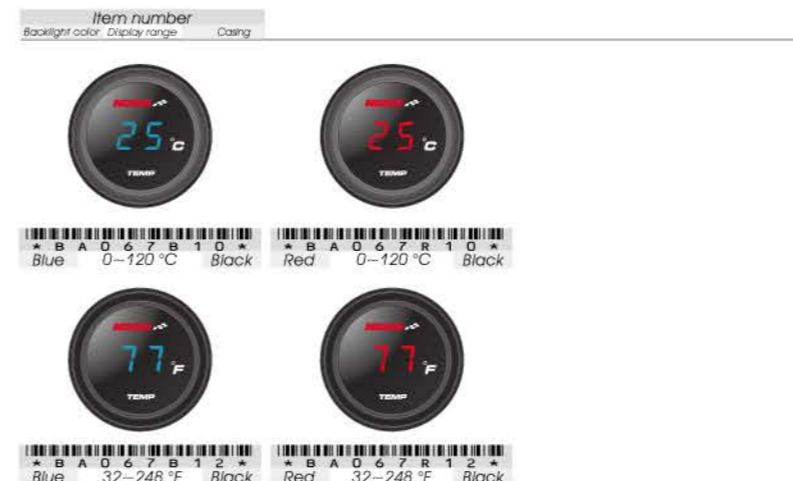

Classic

# TNT Style TNT-05



NEW!



### Speedometer

- Display range : 0 ~ 360 km/h (0 ~ 225 MPH)
- Display unit : 1 km/h (MPH)

### Odometer

- Setting range : 0 ~ 999,999 km (mile)
- Setting unit : 1 km (mile)

### Trip A

- Setting range : 0 ~ 99,999.9 km (mile)
- Setting unit : 0.1 km (mile)

### Trip B

- Setting range : 0 ~ 99,999.9 km (mile)
- Setting unit : 0.1 km (mile)

### Trip O

- Setting range : OFF, -999 ~ 16,000 km (mile)
- Setting unit : 1 km (mile)

### Temperature

- Display range : 0.0~250.0 °C (32.0~482.0 °F)
- Display unit : 0.1 °C (°F)

### Voltmeter

- Display range : DC 8.0~18.0 V
- Display unit : DC 0.1 V

### Fuel Meter

- Display range : 6 levels
- Display unit : 1 level (16.6 %)

### Tachometer

- Display range : 0~9,000 RPM
- Display unit : 500 RPM / 1,000 RPM

### Gear Meter

- Display range : OFF, -, N, 1~the highest gear

Item number



\* B A 0 8 7 0 0 0 \*

TNT style

E-mark approval

## TNT-05 (D80) SPEED & TACHOMETER

Our TNT-05 speed & tachometer features the basic functions such as speed, RPM, ODO, temperature, voltage, clock and the buttons are designed on the lower side of the meter to make your operation more convenient. This meter also has 8 color changeable LCD display.



## Classic

TNT style

E-mark approval

### TNT-05 (D60) SPEEDOMETER

The TNT-05 speedometer features all the basic functions such as speed, odometer, tripmeter, Temperature, Fuel meter, voltage, clock and the buttons are designed on the lower side of the meter to make your operation more convenient.

This meter also has 8 color changeable LCD display. Compact, lightweight, easy to operate, this is our TNT-05 speedometer.



Item number

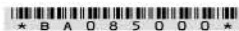

114 / 115

NEW!

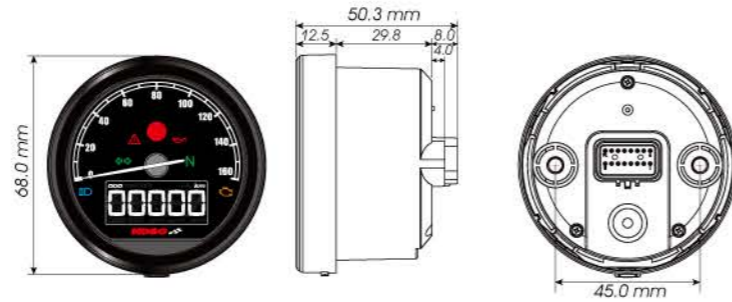

- Speedometer Display range : 0 ~ 160 km/h (MPH)  
Display unit : 1 km/h (MPH)
- Speeding warning setting Display range : 30~160 km/h (19~100 MPH), when setting value is reached or above, warning light will illuminate.  
Display unit : 1 km/h (MPH)
- Max. speed record Display range : 0~160 km/h (MPH), can return to zero manually  
Display unit : 1 km/h (MPH)
- Odometer Setting range : 0 ~ 99,999 km (mile)  
Setting unit : 1 km (mile)
- Trip meter A, B Display range : 0.0~9,999.9 km (mile), can return to zero manually  
Display unit : 0.1 km (mile)
- Temperature Display range : 0.0~250.0 °C (32.0~482.0 °F)  
Display unit : 0.1 °C (°F)
- Overheat warning Setting range : 60~250 °C(140~482 °F), when setting value is reached or above, warning light will illuminate.  
Setting unit : 1 °C (°F)
- Max. temperature record Display range : 0.0~250.0 °C (32.0~482.0 °F), can return to zero manually  
Display unit : 0.1 °C (°F)
- Fuel meter Display range : 10 levels (100%)  
Display unit : 1 levels (10%)
- Low Fuel warning Setting range : 0~30%, when setting value is reached or below, warning light will illuminate.  
Setting unit : 10%
- Clock Setting range : 00:00~23:59 (24H), 01:00~12:59 (12H)
- Voltmeter Display range : DC 8.0 ~ 18.0 V
- Low voltage warning Setting range : DC 8.0~13.0 V, when setting value is reached or below, warning light will illuminate.  
Setting unit : 0.1 V
- Backlight brightness Setting range : 1/3(Darkest)~ 3/3(Brightest)
- Backlight color Setting range : white, red, orange, yellow, green, blue, light blue, purple Loop switch

NEW!

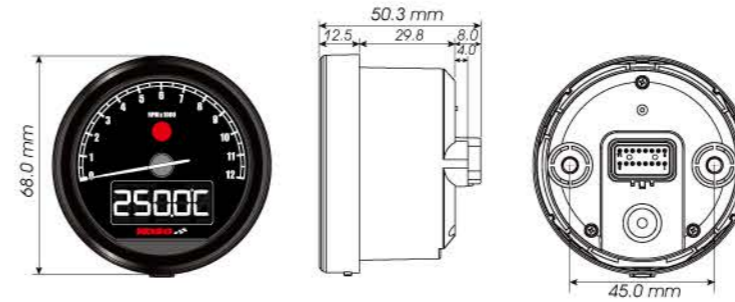

- Tachometer (RPM) Display range : 0 ~ 12,000 RPM
- Pre-Shift Light warning Setting range : 1,000 ~ 11,000 RPM, when setting value is reached or above, warning light will illuminate.  
Setting unit : 100 RPM
- Shift Light warning Setting range : Pre-Shift Light warning setting value +100 ~ 12,000 RPM, when setting value is reached or above, warning light will illuminate.
- Max. rotating speed Display range : 0~12,000 RPM
- The RPM input signal number setting Setting range : P-0.5, 1 ~ 6
- The RPM Input pulse Setting range : LO-ACT, HI-ACT
- Temperature Display range : 0.0~250.0 °C (32.0~482.0 °F)
- Overheat warning Setting range : 60~250 °C(140~482 °F), when setting value is reached or above, warning light will illuminate.  
Setting unit : 1 °C (°F)
- Max. temperature record Display range : 0.0~250.0 °C (32.0~482.0 °F), can return to zero manually
- Voltmeter Display range : DC 8.0 ~ 18.0 V
- Low voltage warning Setting range : DC 8.0~13.0 V, when setting value is reached or below, warning light will illuminate.  
Setting unit : 0.1 V
- Backlight brightness Setting range : 1/5(Darkest)~ 5/5(Brightest)
- Backlight color Setting range : white, red, orange, yellow, green, blue, light blue, purple Loop switch

Item number

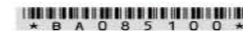

TNT style

### TNT-05 (D60) TACHOMETER

The TNT-05 tachometer features the basic functions such as RPM, Temperature, voltage, clock and the buttons are designed on the lower side of the meter to make your operation more convenient.

This meter also has 8 color changeable LCD display. Compact, lightweight, easy to operate, this is our TNT-05 RPM meter.



Classic TNT style

TNT-05 (D60)

## TNT-05 (D48) SPEEDOMETER

Our TNT-05 speedometer has 7 color changeable LCD display, and the buttons are designed on the lower side of the meter to make your operation more convenient. With the small, compact and user-friendly size, it is perfect for many applications. It also features all the basic functions such as speed, odometer, trip meter, Temperature, Fuel meter, voltage, clock and much more.



NEW!

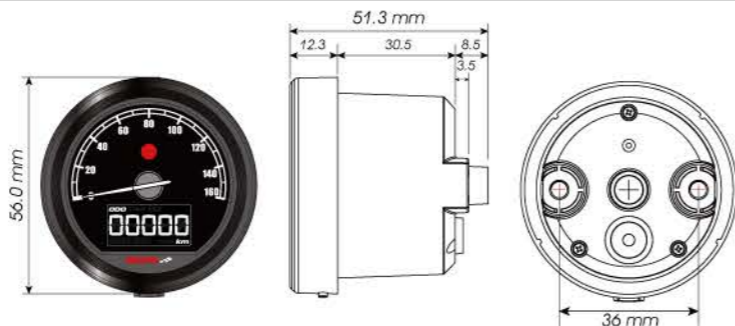

- Speedometer Display range : 0 ~ 160 km/h (MPH)
- Speeding warning setting Display range : 30~160 km/h (19~100 MPH)
- Max. speed record Display range : 0~160 km/h (MPH), can return to zero manually
- Odometer Setting range : 0 ~ 99,999 km (mile)
- Trip meter A, B Display range : 0.0~9,999.9 km (mile), can return to zero manually
- Circumference Setting range : 300~2,500 mm
- Sensitive point Setting range : 1~20 P
- Temperature Display range : 0.0~250.0 °C (32.0~482.0 °F)
- Overheat warning Setting range : 60~250 °C(140~482 °F)
- Max. temperature record Display range : 0.0~250.0 °C (32.0~482.0 °F), can return to zero manually
- Fuel meter Display range : 10 levels (100%)
- Low Fuel warning Setting range : 0~30%
- Fuel Gauge Resistance(Ω) Setting range : 100 Ω, 250 Ω, 270 Ω, 390 Ω, 510 Ω, 1200 Ω, Sw, Custom(learning mode), OFF
- Clock Setting range : 00:00~23:59 (24H), 01:00~12:59 (12H)
- Voltmeter Display range : DC 8.0 ~ 18.0 V
- Low voltage warning Setting range : DC 8.0~13.0 V, when setting value is reached or below, warning light will illuminate.
- Backlight color Setting range : white, red, orange, yellow, green, blue, purple Loop switch

Item number



NEW!

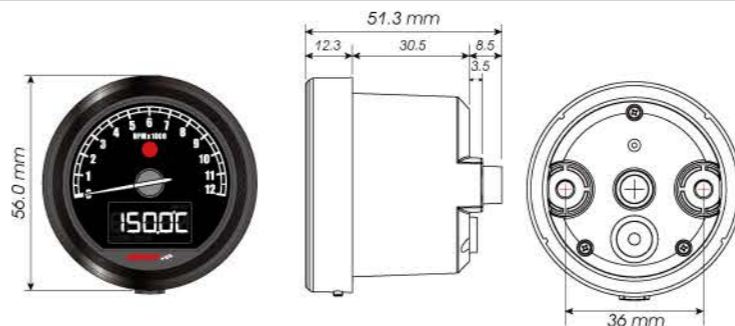

- Tachometer (RPM) Display range : 0 ~ 12,000 RPM
- Pre-Shift Light warning Setting range : 1,000 ~ 11,000 RPM, when setting value is reached or above, warning light will illuminate. Setting unit : 100 RPM
- Shift Light warning Setting range : Pre-Shift Light warning setting value +100 ~ 12,000 RPM, when setting value is reached or above, warning light will illuminate.
- Max. rotating speed Display range : 0~12,000 RPM
- The RPM input signal number setting Setting range : P-0.5, 1 ~ 6
- The RPM input pulse Setting range : LO-ACT, HI-ACT
- Temperature Display range : 0.0~250.0 °C (32.0~482.0 °F)
- Overheat warning Setting range : 60~250 °C(140~482 °F), when setting value is reached or above, warning light will illuminate. Setting unit : 1 °C (°F)
- Max. temperature record Display range : 0.0~250.0 °C (32.0~482.0 °F), can return to zero manually
- Voltmeter Display range : DC 8.0 ~ 18.0 V
- Low voltage warning Setting range : DC 8.0~13.0 V, when setting value is reached or below, warning light will illuminate. Setting unit : 0.1 V
- Backlight color Setting range : white, red, orange, yellow, green, blue, purple Loop switch

Item number



## TNT-05 (D48) TACHOMETER

Our TNT-05 tachometer has 7 color changeable LCD display, and the buttons are designed on the lower side of the meter to make your operation more convenient. With the small, compact and user-friendly size, it is perfect for many applications. It also features a backlight, has a RPM display warning and also keeps track of your max RPM and much more.



E-mark approval

### TNT D64

Our TNT D64 multifunction speedometer is the perfect meter for all the street bike, classic bike and cafe racer with more standard 64mm diameter size. It uses a stepper motor for a fast and smooth response. The instrument features many functions such as, speed, odometer, trip meter, fuel meter, clock, voltage, shift light, indicator light and more... This meter is available in black or white face for you to make your own choice!

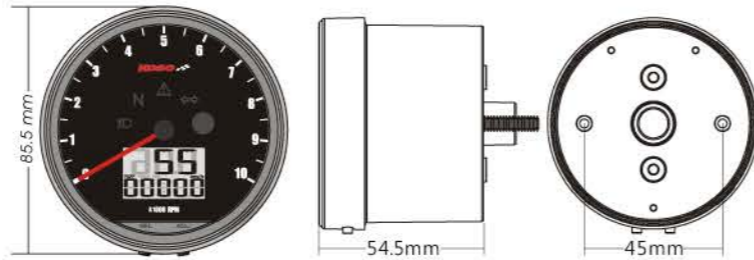

- Speedometer Display range : 0 ~ 360 km (0 ~ 225 mile)  
Display unit : km/h & MPH or alternative
- Odometer Display range : 0~99999 km (mile), reset automatically after 99999 km (mile)
- Trip meter A . B Display range : 0~9999.9 km (mile), reset automatically after 0~9999.9 km (mile)
- Top speed record Display range : 0~360 km/h (0~225 MPH)
- Tire circumference Display range : 20,000 RPM
- The shift light Setting range : 5000~20000 RPM
- Warning RPM input pulse F-OFF (LIGHT ON) \*F-ON (FLASH)  
Display range : 0.5, 1~6
- The RPM input pulse Setting range : HI-ACT (Positive wave pulse)  
Lo-ACT (Negative wave pulse)
- Max. RPM record Display range : 0~20,000 RPM
- Fuel meter Display range : 0~100%
- Insufficient fuel warning Setting unit : 100 Ω , 250 Ω , 510 Ω , USER  
24 H
- Clock
- Backlight brightness Setting range: 1-5 (Darkest)~5-5 (Brightest)
- Effective voltage DC 12V
- Effective temperature range -10 ~ +60 °C
- Meter standard JIS D 0203 S2
- Meter size 85.5 X 54.5 mm
- Meter weight Around 330 g
- Telltales
  - High beam (Blue)
  - Neutral (Green)
  - Reserve (RED)
  - Repeater (Green)
  - RPM Shift light (RED)

Item number  
Backlight color: Display range Casing



\*BA058100\*  
white 0~360 km/h Black



- Speedometer Display range : 0 ~ 360 km (0 ~ 225 mile) switchable
- Speedometer unit Display range : km ~ mile
- Over speed warning Setting range : 30 ~ 360 km (19 ~ 225 mile), warning sign will be given once exceed (include) setting value.
- Tire circumference Display range : 300 ~ 2,500 mm
- Internal and external odometer Display range : 0 ~ 999,999 km (mile) return to zero upon exceed
- Trip meter A, B Display range : 0 ~ 9,999.9 km (mile) returns to zero upon exceed
- Gear meter Display range : off, highest gear, N and highest gear, show all (N | 1 ~ 6)
- Tachometer Display range : 0 ~ 10,000 RPM
- RPM signal Display range : P-0.5 ~ P-1 ~ P-24
- The RPM input pulse Display range : HIact ~ LOact
- Thermometer Display range : 0 ~ 250 °C (32 ~ 482 °F)
- RPM shift light · Warning 1 · Warning 2
- Fuel meter 100Ω · 250Ω · 270Ω · 510Ω · 1200Ω · fuel switch · USER
- Clock Setting range : 12 / 24 hour format
- Voltmeter Display range : 8 ~ 18 V
- Under voltage Setting range : 8.0 ~ 18.0 V, warning sign will be given once below (include) setting value.
- Backlight brightness Setting range : 1 / 5 (darkest) ~ 5 / 5 (brightest)
- Backlight color Setting range : red, orange, yellow, green, blue, light blue, purple, white
- Maintenance millage Setting range : OFF, 500 ~ 16,000 km
- Operating voltage DC 8V to DC 16V
- Temperature range -10 ~ +60°C
- Specifications JIS D 0203 (S2)
- Meter Size / Meter Weight D94.7 X 55.8 mm / 165 g
- Indication light
  - RPM shift light
  - Warning 1
  - Warning 2
  - Neutral
  - Trun signal
  - High beam light
  - Engine warning light

Item number  
Backlight color: Display range Casing



\*BA051400\* 8 color 0~360 km/h Chrome  
\*BA051401\* 8 color 0~360 km/h Chrome  
\*BA051410\* 8 color 0~360 km/h Black  
\*BA051411\* 8 color 0~360 km/h Black

TNT style

E-mark approval

### TNT-04

The whole new TNT-04 meter is perfect instrument for Classic application or special Cafe Racer project. It combine with both needle tach and digital speed display to present your special taste of bike. The meter is fully equipped with all functions you need such as tachometer, speedometer, odometer, trip meter, shift light, fuel level, indicator lights, gear indicator and also the multiple warning reserved light you could make your own selection. Furthermore, this TNT-04 offer you 7 different colors for backlight to ride with your own style!



# Classic

## TNT style

E-mark approval

### TNT-01S SPEEDOMETER

Our TNT multi-functions speedometer is the perfect meter for all the Café racers and special projects. The TNT meter use a stepper motor for a fast and smooth response. The instrument features many functions such as, speed, odometer, trip meter, fuel gauge, clock, voltage, shift light, indicator light and more. This meter is available in black or white face and includes the installation brackets and speed sensor.



- Speedometer Display range: 0~360 km/h (0~225 MPH)  
Display unit: km/h & MPH or alternative
- Odometer Display range: 0~99999 km (mile), reset automatically after 99999 km (mile)  
Display unit: 1 km (mile)
- Trip meter A . B Display range: 0~9999.9 km (mile), reset automatically after 0~9999.9 km (mile)  
Display unit: 0.1 km (mile)
- Top speed record Display range: 0~360 km/h (0~225 MPH)
- Tire circumference Setting range: 300~2,500 mm  
Sensor point: 1~20 Setting unit: 1
- Clock 24 H
- Backlight brightness Setting range: 1-5 (Darkest)~5-5 (Brightest)  
Setting unit: Each level represents 20%
- Effective voltage DC 12v
- Effective temperature range -10~+60 °C
- Meter standard JIS D 0203 S2
- Meter size 85.5 X 54.5 mm
- Meter weight Around 330 g
- Telltales High beam (Blue) E D  
Neutral (Green) N  
Warning Light (RED) Δ  
Repeater (Green) ⇄

Item number Backlight color Display range Casing



\* B A 0 3 5 1 7 3 \* White 0~140 Black  
\* B A 0 3 5 1 7 4 \* White 0~240 Black

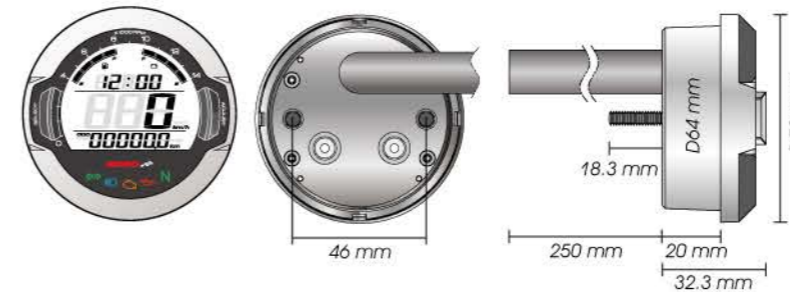

- Speedometer Display range: 0~360 km/h (0~223 MPH)  
Display unit: km/h & MPH for alternative
- Odometer Display range: 0~99999.9 km (mile), reset automatically after 99999 km (mile)  
Display unit: 0.1 km (mile)
- Trip meter A/B Display range: 0~999.9 km (mile), reset automatically after 999.9 km (mile)  
Display unit: 0.1 km (mile)
- Fuel / Remaining distance Display range: 999.9~0 km (mile)  
Display unit: 0.1 km (mile)
- Tire circumference setting Setting range: 300~2,500 mm  
Setting unit: 1 mm. Pulse setting: 1~20
- Tachometer Display range: 15 levels
- Fuel meter Display range: 4 levels
- Fuel resistance Setting range: 100Ω, 250Ω, 510Ω, 1,200Ω
- Clock 24 H
- Digital Volt meter Display range: DC 5~24 V. Flashing warning when Voltage lower than 8 V or higher than 18 V  
Display range: 4 levels  
Display unit: 1 level (low) - DC 11.6 V~12.0 V  
2 level - DC 12.1 V~12.5 V  
3 level - DC 12.6 V~13 V  
4 level (high) - DC 13.1 V
- Backlight brightness adjust Setting range: 1-5 (Darkest) ~ 5-5 (Brightest)
- Effective voltage DC 12 V
- Effective temperature range -10~+60 °C
- Meter standard JIS D 0203 S2
- Meter size (D X H) D72 X 32.3 mm
- Meter weight Around 240 g
- Telltales Neutral(green) EOBD (Amber) Oil (Red)  
 High beam (Blue) Repeater(Green)

Item number Backlight color Display range Panel color

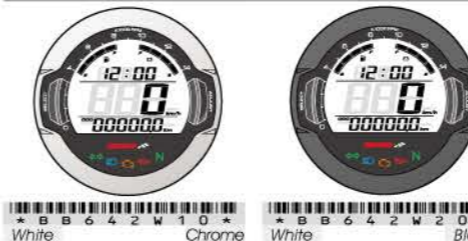

\* B B 6 4 2 W 1 0 \* White Chrome  
\* B B 6 4 2 W 2 0 \* White Black

## DL style

E-mark approval

### D64 DL-03SR

The DL-03SR GP style speedo feature about all the functions you need to go on the street. The large digits, indicator lights, and backlight make this instrument easy to read, even at night. The universal speed sensor and bracket allow to install this meter on about any applications. Compact, lightweight, easy to operate, this is our DL-03SR GP style speedometer.



DL-04

The universal version of the DL-04 gauge has been developed for all our motorcycle lovers. This multifunction meter has a modern negative LCD screen easy to read and which will give an urban look to any bike.

The DL-04 will give you all the information you need and a variety of features such as speed, odometer, tripmeter, hour meter, voltage and clock as well as 6 indicator lights.



NEW!

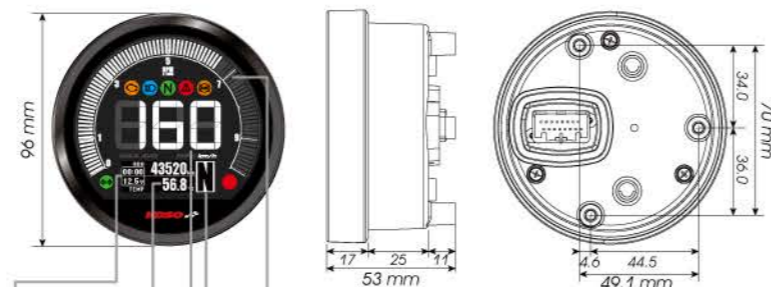

- Speedometer**
  - Display range : 0 ~ 360 km/h (0 ~ 225 MPH)
  - Display unit : 1 km/h (MPH)
- Temperature**
  - Display range : 0.0~250.0 °C (32.0~482.0 °F)
  - Display unit : 0.1 °C (°F)
- Clock**
  - Setting range : 00:00~23:59 (24H)
  - 01:00~12:59 (12H)
- Voltmeter**
  - Display range : DC 8.0 ~ 18.0 V
  - Display unit : DC 0.1 V
- Tachometer**
  - Display range : 0~10,000 RPM / 0~15,000 RPM
  - Display unit : 111 RPM / 166 RPM
- Gear Meter**
  - Display range : OFF, -, N, 1~the highest gear



- Speedometer Display range : 0 ~ 360 km/h (0 ~ 225 MPH)  
Display unit : 1 km/h (MPH) Switchable
- Speeding warning setting Setting range : 30~360 km/h (19~225 MPH), When exceeding the set value (inclusive), the value flickers and the warning signal will be lit according to the setting. Setting unit : 1 km/h (MPH)
- Max. speed record Display range : 0 ~ 360 km/h (0 ~ 225 MPH), can return to zero manually  
Display unit : 1 km/h (MPH)
- Odometer Setting range : 0 ~ 99,999 km (mile)  
Setting unit : 1 km (mile)
- Trip meter A, B Display range : 0.0~9,999.9 km (mile), can return to zero manually  
Display unit : 0.1 km (mile)
- Motor oil maintenance (Trip O) Display range : OFF, -999~16,000 km (-999~10,000 mile), can be reset manually  
Display unit : 1 km (mile)
- Motor oil maintenance warning Setting range : OFF, 500 ~ 16,000 km(300~10,000 mile)  
When lower than 0 km (mile), the value shows on the screen and flickers for warning, and the warning signal will be lit according to the setting.  
Setting unit : 100 km(mile)
- Circumference Setting range : 300~2,500 mm  
Setting unit : 1 mm
- Sensitive point Setting range : 1~20 P  
Setting unit : 1 P
- Gear Meter Display range : OFF, -, N, 1~the highest gear
- Max. Gear record Display range : -, N, 1~the highest gear, can return to zero manually
- Tachometer Display range : 0~10,000 RPM / 0~15,000 RPM  
Display unit : 111 RPM / 166 RPM
- Shift light warning Setting range : 1,000~10,000 RPM / 0~15,000 RPM, When exceeding the set value (inclusive), the warning signal will be lit according to the setting.  
Setting unit : 100 RPM
- Max. RPM record Display range : 1,000~10,000 RPM / 0~15,000 RPM, can return to zero manually.  
Display unit : 111 RPM / 166 RPM
- Temperature Display range : 0.0~250.0 °C (32.0~482.0 °F)  
Display unit : 0.1 °C (°F)
- Overheat warning setting Setting range : 60~250 °C(140~482 °F), When exceeding the set warning value, the value flickers, and the warning signal will be lit according to the setting.  
Setting unit : 1 °C (°F)
- Max. temperature record Display range : 0.0~250.0 °C (32.0~482.0 °F), can return to zero manually  
Display unit : 0.1 °C (°F)
- Fuel meter Display range : 6 levels  
Display unit : 1 level(16.6 %)
- Fuel resistance Setting range : 100 Ω, 250 Ω, 270 Ω, 390 Ω, 510 Ω, 1200 Ω, Switch, Custom ,OFF
- Fuel warning setting Setting range : 0 ~ 3/6 grid  
Setting unit : 1 grid
- Clock Setting range : 00:00~23:59 (24H)  
01:00~12:59 (12H)
- Voltmeter Display range : DC 8.0 ~ 18.0 V  
Display unit : DC 0.1 V
- Low voltage warning Setting range : DC 8.0~13.0 V, When lower than the set warning value for over five seconds, the value flickers, and the warning signal will be lit according to the setting.  
Setting unit : DC 0.1 V
- Backlight brightness Setting range : 1/5 (darkest)~ 5/5 (brightest)  
Setting unit : 1/5(20%)
- Unit Speed unit : km/h , MPH  
Temperature unit : °C (Celsius) and °F (Fahrenheit)
- Operating voltage DC 12V
- Operating temperature -20~ 85 °C
- Storage temperature -30~ 90 °C
- Specification JIS D 0203 (S2)
- Meter Size D 96 mm
- Meter Weight About 184 g
- Indicator Check engine light (Amber)  
High beam light (Blue)  
Neutral light (Green)  
Warning light (Red)  
ABS light (Amber)  
Turn signal light (Green)  
Shift light (Red)

## Meter Bracket



Meter bracket

Model	Item number
EGT, DB-01 / R	* B E 0 0 4 K 0 5 *



Handle bar meter bracket

Model	Handbar size	Item number
EGT, DB-01 / R	7/8"	* B E 0 1 8 K 0 0 *
	1 1/8"	* B E 0 0 3 K 0 1 *



Meter bracket (For RX3 meter)

Model (Suzuki)	Item number
GSX-R150	* B Z 0 0 1 0 0 4 *



Meter bracket (For RX4 meter)

Model (Yamaha)	Item number
XRS 700 (2015-2021)	* B E 0 8 1 0 0 0 *



Meter bracket (For Switch)

Model	Item number
Power Test & EGT	* B E 0 0 0 M 0 1 *



Meter bracket (For Switch)

Model	Item number
Mini style	* B 0 0 0 6 S 0 0 *



Meter bracket (For RX4 meter)

Model (Yamaha)	Item number
XRS 900 (2016-2021)	* B E 0 8 1 0 1 0 *



Meter bracket (For RX4 meter)

Model (Yamaha)	Item number
MT-09 (2014-2016)	* B E 0 8 1 0 2 0 *



Handle bar meter bracket

Model	Handbar size	Item number
Mini style	7/8"	* B E 0 0 2 K 0 2 *
	1 1/8"	* B E 0 0 3 K 0 3 *



Meter bracket (For RX3 meter)

Model (Honda)	Item number
MSX / Grom 2016~	* B Z 0 0 1 0 0 0 *



Meter bracket (For RX3 meter)

Model (Honda)	Item number
Monkey 125	* B Z 0 0 1 0 0 1 *



Meter bracket (For RX3 meter)

Model (Yamaha)	Item number
Force 155	* B Z 0 0 1 0 0 2 *



## Tachometer installation instruction

### RPM sensor

## INSTRUCTIONS

To improve the possibility to use the tachometer on different machines, we provide you 3 different ways to install the rpm sensor wiring. (only available on RX1N, RS DYNO meter dyno edition, and GP style universal tachometer 48mm & 55mm now.)

You could choose to wrap the wiring on the spark plug wire, connect to the ignition coil positive wire, or the pick up.

We know this may still not enough to fit every different model on the world, but we are doing our best to make it possible. the new KOSO GP style universal tachometer could fit most of the scooter and ATV with CDI ignition system on the market. there are different ignition systems exit on the market, and we will keep developing the new product for it.

as for our old product, we will adopt the new technology when upgrading them.

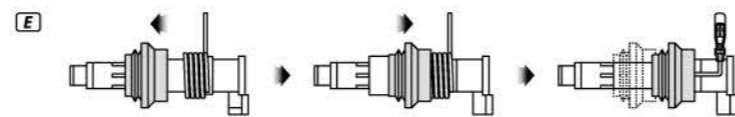
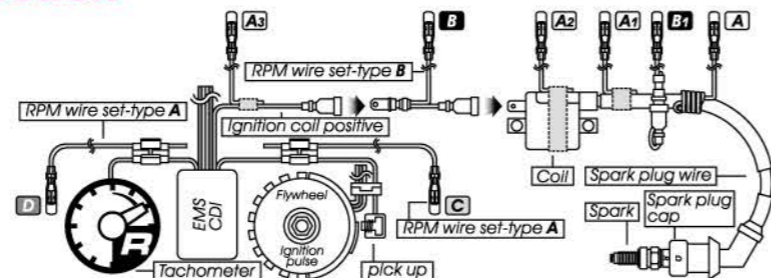

### SCOOTER

Manufacturer	Model	A	B	C	Setting
YAMAHA	JOG 50	O	Orange	White/Red	2C-1P
	JOG 90	O	Orange	White/Blue	2C-1P
	JOG 100	X	X	White/Blue	2C-1P
	RS 100	O	X	White/Blue	2C-1P
	MAJESTY 125	O	Orange	White/Blue	2C-1P
YAMAHA/MBK	SV MAX 125	O	X	X	2C-1P
	CYGNUS 125	X	X	White/Green	2C-1P
	GTR 125	O	X	White/Blue	2C-1P
	AEROX 50	O	X	White/Blue	2C-1P
	SLIDER 50	O	-	X	2C-1P
GILERA	CHOI NORI	O	White/Blue	White/Red	2C-1P
	RUNNER 50	O	X	O	2C-1P
PEUGEOT	X-FIGHT 50	X	Yellow/Blue	Blue/Yellow	2C-1P

**A TYPE** Wrap the rpm wire onto the ignition cable wire.

**B TYPE** Connect the rpm wire to the coil positive wire.

**C TYPE** Connect the rpm wire to the pick up.

New tachometer test result:  
ATV

Manufacturer	Model	A	B	C	Setting
HONDA	Predator 500	O	O	O	2C-1P
	Sportsman 600	X	O	X	2C-1P
	Sportsman 700	X	O	X	2C-1P
YAMAHA	TRX 400 EX	O	O	O	2C-1P
	TRX 450 R	O	O	O	2C-1P
YAMAHA	YFZ 450	O	X	X	2C-1P
	RAPTOR	O	O	X	2C-1P
BOMBARDIER	LTZ 400	O	O	X	2C-1P
	DS 650	O	O	X	2C-1P

Main switch wiring reference:

	Power	Key on	Ground
YAMAHA	Red	Brown	Black
HONDA	Red	Red/Black	Green
SUZUKI	Red	Black	Green
KAWASAKI	White	Brown	Black/Yellow
KYMCO	Red	Black	Green
SYM	Red	Black	Green
PGO	Red/White	Orange	Black

**NOTE** The color listed above may differ depending on the model.

RPM wiring reference:

YAMAHA	Yellow/Black	BUELL	Ground
HONDA	Yellow/Green	CAGIVA	Gray/Green
SUZUKI	Yellow / Blue	DUCATI	Gray/Green
KAWASAKI	Light Blue	H-D	Pink
APRILIA	Gray / Violet	MV	Gray/Yellow
BMW	Black	TRIUMPH	Red
BENELLI	Geay/Violet		

**NOTE** The color listed above may differ depending on the model.

Fuel Indicator wiring reference:

YAMAHA	Green	KYMCO	Yellow/White
HONDA	Yellow/White	SYM	Yellow/White
SUZUKI	Yellow/White	PGO	Gray
KAWASAKI	Black/L Green		

⚠ The fuel sensor is electronic type, please don't parallel connection with the original-otherwise the fuel gauge won't display.  
**The wrong installation of the fuel wiring may cause the meter break.**



### RPM sensor

## INSTRUCTIONS

For the models comes with the new ignition coil, please wrap the RPM wire st least 5 times around the spark plug as the above drawing.

For the model with the normal coil with spark plug wire, please wrap the sensor wire around 3~5 times on the spark plug wire to get the signal.

If you can't catch a good signal (EX. the meter stopped counting the time after some times) from the spark plug wire, you could also try the 3 different methods showed to get a better signal, too.

For the model comes with the new ignition coil (the type without the spark plug wire), please follow the above 3 methods showed on drawing E to catch the signal.

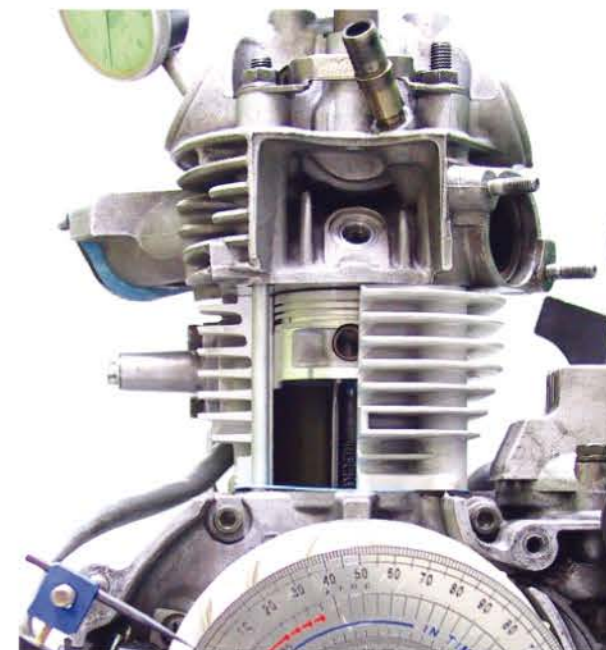

# Speed Sensor

## Passive speed sensor instruction

The more magnet sensor points are, the less the display interval is. when installing the magnet, please put the magnet with N-mark side face the outside and put them averagely to avoid wrong signal.

- EX. 1 If your disk has 3 screws, you could install 1 or 3 magnets to catch the speed.
- EX. 2 If your disk has 4 screws, you could install 1-2 or 4 magnets to catch the speed.
- EX. 3 If your disk has 5 screws, you could install 1 or 5 magnets to catch the speed.
- EX. 4 If your disk has 6 screws, you could install 1-2-3 or 6 magnets to catch the speed.

After finishing the magnet installation and sensor point setting, please move your tire to test the speedometer work or not.

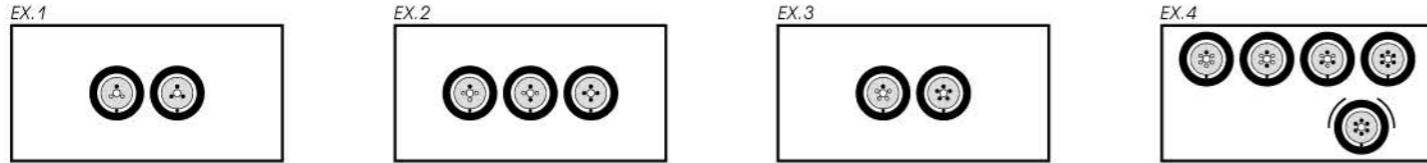

**Passive speed sensor**

A. SH-01		B. SH-01	
Length	Item number	Length	Item number
900mm	*BF019J00*	900mm	*BF019000*
1,150mm	*BF019J01*	1,150mm	*BF019001*
1,350mm	*BF019J02*	1,350mm	*BF019002*
1,550mm	*BF019J04*	1,550mm	*BF019004*
1,750mm	*BF019J05*	1,750mm	*BF019005*
2,000mm	*BF019J06*	2,000mm	*BF019006*
4,000mm	*BF019J07*	4,000mm	*BF019007*

**Reed speed sensor (FOR EX Series)**

Length	Item number
1450mm	*BF200000*

**Reed petal speed sensor (FOR DB02)**

Length	Item number
1450mm	*BF650J02*

## Active speed sensor instruction

The active speed sensor could be installed by the metal parts to detect the speed.

- EX. 1 The disc screw.
- EX. 2 The disc to detect the disc gap.
- EX. 3 The sprocket to detect the disc gap.

We will suggest you to catch the speed from the disc screws. The more the sensor points are, the better the speed accuracy is. The maximum sensor points the speed sensor could detect is 60 points per turn.



**Active speed sensor**

A. SA-01 (water-proof connector)		B. SA-01 (3 Pin connector)	
Length	Item number	Length	Item number
900mm	*BF570J00*	900mm	*BF570000*
1,150mm	*BF570J01*	1,150mm	*BF570001*
1,350mm	*BF570J02*	1,350mm	*BF570002*
1,550mm	*BF570J04*	1,550mm	*BF570004*
1,750mm	*BF570J05*	1,750mm	*BF570005*
2,000mm	*BF570J06*	2,000mm	*BF570006*
4,000mm	*BF570J07*	4,000mm	*BF570007*

**Active speed sensor**

A. SA-07 (water-proof connector)		B. SA-07 (3 Pin connector)	
Length	Item number	Length	Item number
900mm	*BF640J00*	900mm	*BF640000*
1,150mm	*BF640J01*	1,150mm	*BF640001*
1,350mm	*BF640J02*	1,350mm	*BF640002*
1,550mm	*BF640J04*	1,550mm	*BF640004*
1,750mm	*BF640J05*	1,750mm	*BF640005*
2,000mm	*BF640J06*	2,000mm	*BF640006*
4,000mm	*BF640J07*	4,000mm	*BF640007*

**Active speed sensor**

A. SA-09 (water-proof connector)	
Length	Item number
1,350mm	*BF642000*

**ACCESSORY**

## Speed Sensor & Accessory



### GPS Speed signal converter kit

Item number  
\* K K 0 0 0 0 0 1 \*

### GPS Speed signal converter only

Item number  
\* K K 0 0 0 0 0 0 \*

### GPS transmitter only

Item number  
\* B F 0 1 8 0 0 0 \*



### L type Speed sensor bracket

sensor	Item number
R20	* B I 0 0 3 S 0 0 *
R20/25	* B I 0 0 3 S 0 1 *



### S type Speed sensor bracket

Size	Item number
M8	* B I 0 0 2 S 0 8 *
M10	* B I 0 0 2 S 1 0 *



### Sprocket magnet screw

sensor	Item number
M6 X P1.0 X 16.5L	* B F 0 1 0 6 2 0 *
M6 X P1.0 X 14L	* B F 0 1 0 6 4 0 *
M6 X P1.0 X 19.6L	* B F 0 1 0 6 5 0 *
M6 X 7.6L	* B F 0 1 0 6 6 0 *



### Disc magnet screw

sensor	Pcs.	Item number
5/16 X P18 X 18.25L	1	* B F 0 1 0 5 0 0 *
M5 X P0.8 X 12L	1	* B F 0 1 0 5 1 0 *
M8 X P1.25 X 29L	1	* B F 0 1 0 8 0 0 *
M8 X P1.25 X 29L	2	* B F 0 1 0 8 1 1 *
M8 X P1.25 X 22.5L	1	* B F 0 1 0 8 2 0 *
M8 X P1.25 X 27.5L	1	* B F 0 1 0 8 3 0 *
M6 X P1.0 X 24L	1	* B F 0 1 0 6 0 0 *
M6 X P1.0 X 19.7L	1	* B F 0 1 0 6 1 1 *
M6 X P1.0 X 12.6L	1	* B F 0 1 0 6 3 0 *



### Magnet

Size	Pcs.	Item number
D6 X 5 mm	3	* B F 0 1 0 7 0 0 *
D9 X 2.5 mm	1	* B F 0 1 0 7 0 1 *
D10 X 3 mm	1	* B F 0 1 0 7 0 2 *
D15 X 5 mm	1	* B F 0 1 0 7 0 3 *
D6 X 5 mm	1	* B F 0 1 0 7 0 4 *



### Magnet & E ring

Size	Item number
D11 x 6.5H x d9.5 mm	* B F 0 0 9 1 1 0 *

### TYPE A~C

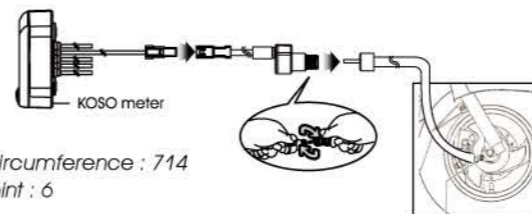

- The tire circumference : 714
- Sensor point : 6

### TYPE D

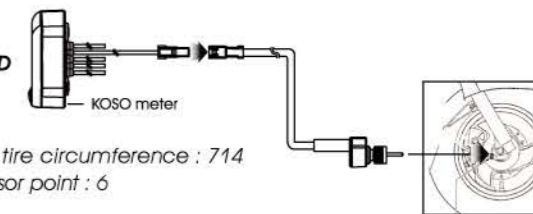

- The tire circumference : 714
- Sensor point : 6



### Speed sensor (for Triumph BMW)

Model	Item number
A. 900 mm	* B F 1 9 0 0 0 0 *
B. 900 mm	* B F 1 9 0 0 1 0 *

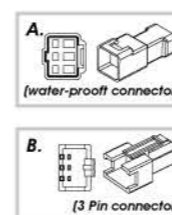

### Speed sensor (for BMW)

Model	Item number
A. 900 mm	* B F 5 8 4 0 0 0 *
B. 900 mm	* B F 5 8 4 0 1 0 *

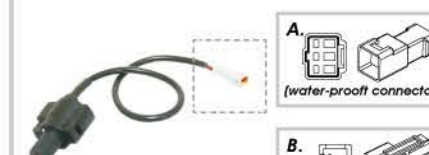
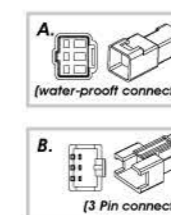

### Speed signal converter A

Model	Item number
SR.X-FIGHT.BOOSTER A	* B F 7 0 1 0 0 1 *
SR.X-FIGHT.BOOSTER B	* B F 7 0 1 0 0 0 *

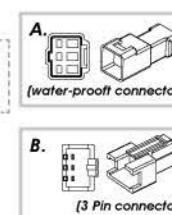

### Speed signal converter B

Model	Item number
A. Runner	* B F 8 0 1 0 0 1 *
B. Runner	* B F 8 0 1 0 0 0 *

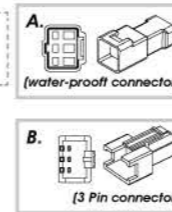

### Speed signal converter C

Model	Item number
A. JIS Type A	* B F 5 8 0 0 1 1 *
B. JIS Type A	* B F 5 8 0 0 0 1 *

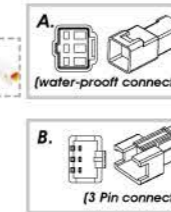

### Speed sensor (for Triumph BMW)

Model	Item number
A. JIS Type a	* B F 5 8 0 0 1 0 *
B. JIS Type a	* B F 5 8 0 0 0 0 *

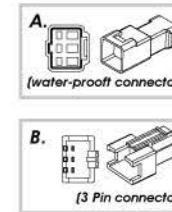

### Analog to digital signal converter

Model	Item number
A. JIS Type a	* B F 5 8 2 0 0 0 *
B. JIS Type a	* B F 5 8 2 0 0 2 *

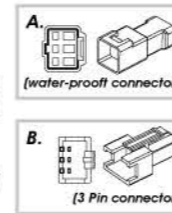

## Lambda Sensor & Accessory



Active Bosh O<sup>2</sup> Sensor  
Item number  
\* B 0 0 0 2 0 0 5 \*



Race type O<sup>2</sup> Sensor  
Item number  
\* B G 0 0 0 S 0 1 \*



O<sup>2</sup> Sensor adapter screw kit  
Size Item number  
M18 x P1.5 \* B 0 0 0 2 0 0 2 \*  
M12 x P1.25 \* B 0 0 0 2 0 0 6 \*



Wide band O<sup>2</sup> Sensor  
Item number  
\* B 0 0 0 2 0 0 4 \*

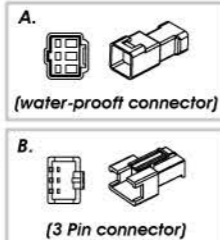

O<sup>2</sup> Signal extension wire  
Model Item number  
A. \* B 0 0 0 2 0 0 1 \*  
B. \* B 0 0 0 2 0 0 3 \*



Temperature sensor  
0~250°C (With water-proof connector)  
Size Item number  
PT 1/8 X 28 \* B F 0 3 0 0 0 0 \*  
PT 3/8 X 19 \* B F 1 3 0 0 1 0 \*  
M10 X P1.0 \* B F 1 0 0 0 0 0 \*  
M10 X P1.25 \* B F 1 0 0 0 0 1 \*  
M12 X P1.5 \* B F 1 2 0 0 0 0 \*  
M14 X P1.25 \* B F 1 4 0 0 0 0 \*  
M14 X P1.5 \* B F 1 4 0 0 0 1 \*  
M16 X P1.5 \* B F 1 6 0 0 0 0 \*  
M18 X P1.5 \* B F 1 8 0 0 0 0 \*



Temperature sensor  
0~250°C (With water-proof connector)  
Size Item number  
PT 3/8 X 19 \* B F 0 3 0 0 1 2 \*  
M12 X P1.5 \* B F 1 2 0 0 0 3 \*  
M14 X P1.5 \* B F 1 4 0 0 0 5 \*  
M14 X P1.25 \* B F 1 4 0 0 0 6 \*  
M16 X P1.5 \* B F 1 6 0 0 0 2 \*  
M18 X P1.5 \* B F 1 8 0 0 0 2 \*

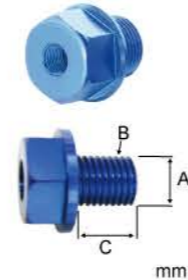

Temperature sensor adapter  
A B C Item number  
M12 x P1.5 x 15L \* B G 2 4 1 2 1 5 \*  
M14 x P1.25 x 15L \* B G 2 4 1 4 1 2 \*  
M14 x P1.5 x 15L \* B G 2 8 1 4 1 5 \*  
M16 x P1.5 x 15L \* B G 3 0 1 6 1 5 \*  
M18 x P1.5 x 15L \* B G 3 0 1 8 1 5 \*  
M20 x P1.0 x 15L \* B G 3 0 2 0 1 0 \*  
M20 x P1.5 x 15L \* B G 3 0 2 0 1 5 \*



Temperature sensor  
0~150°C  
Size Item number  
PT 1/8 X 28 \* B F 0 3 0 1 2 5 \*  
M10 X P1.0 \* B F 1 0 0 1 0 0 \*  
M10 X P1.25 \* B F 1 0 0 1 2 5 \*  
M12 X P1.5 \* B F 1 2 0 1 2 5 \*  
M14 X P1.25 \* B F 1 4 0 1 2 5 \*  
M14 X P1.5 \* B F 1 4 0 1 5 0 \*  
M16 X P1.5 \* B F 1 6 0 1 5 0 \*  
M18 X P1.5 \* B F 1 8 0 1 5 0 \*



Water temp adapter  
(With Temperature sensor)  
Size Item number  
14 mm \* B G 1 1 4 0 0 1 \*  
16 mm \* B G 1 1 6 0 0 1 \*  
18 mm \* B G 1 1 8 0 0 1 \*  
22 mm \* B G 1 2 2 0 0 1 \*  
26 mm \* B G 1 2 6 0 0 1 \*



Water temp adapter  
Size Item number  
14 mm \* B G 1 1 4 0 0 0 \*  
16 mm \* B G 1 1 6 0 0 0 \*  
18 mm \* B G 1 1 8 0 0 0 \*  
22 mm \* B G 1 2 2 0 0 0 \*  
26 mm \* B G 1 2 6 0 0 0 \*

## Temper Sensor & Accessory

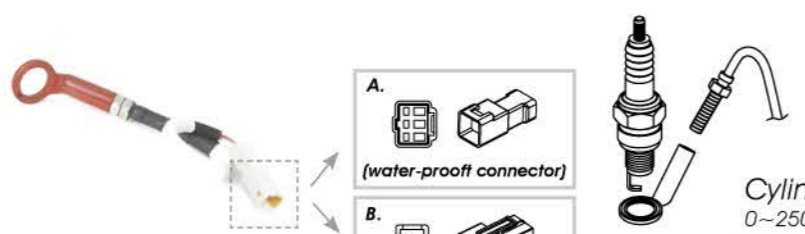

**Cylinder head temp sensor**  
0~250°C

Size	Item number
<b>A.</b> 10 mm	* K I 0 0 1 R 1 1 *
14 mm	* K I 0 0 1 R 1 5 *
<b>B.</b> 10 mm	* K I 0 0 0 R 1 0 *
14 mm	* K I 0 0 0 R 1 4 *

**A.** (water-proof connector)  
**B.** (3 Pin connector)



**EGT Sensor**  
200~1000°C

Type	Item number
Sport	* B F 0 0 0 0 0 4 *



**EGT Sensor**  
200~1000°C

Type	Item number
Race	* B F 0 0 0 0 0 5 *



**EGT Sensor clamp**

Type	Size	Item number
Sport	40-64 mm	* B 1 5 2 0 0 0 1 *
Sport	60-80 mm	* B 1 5 2 0 0 0 2 *



**EGT Sensor clamp**

Type	Size	Item number
Race	21-38 mm	* B 1 5 2 0 0 0 3 *
Race	40-64 mm	* B 1 5 2 0 0 0 4 *

### Adapter wire for cylinder head temp

Type	Item number
<b>A.</b> YAMAHA - CYGNUS.BWS.GTR.MIO.NEW CUXI	* B 0 0 0 3 2 4 1 *
<b>B.</b> YAMAHA - S-MAX	* B 0 0 0 3 2 4 3 *
<b>C.</b> KYMCO - RACING 150.VJR.QUANNON	* B 0 0 0 3 2 4 0 *
<b>D.</b> SYM - RX 110 / HONDA - SCOOPY	* B 0 0 0 3 2 4 5 *
<b>E.</b> HONDA - PCX.VARIO	* B 0 0 0 3 2 4 4 *
<b>F.</b> HONDA - MSX	* B 0 0 0 3 2 4 6 *

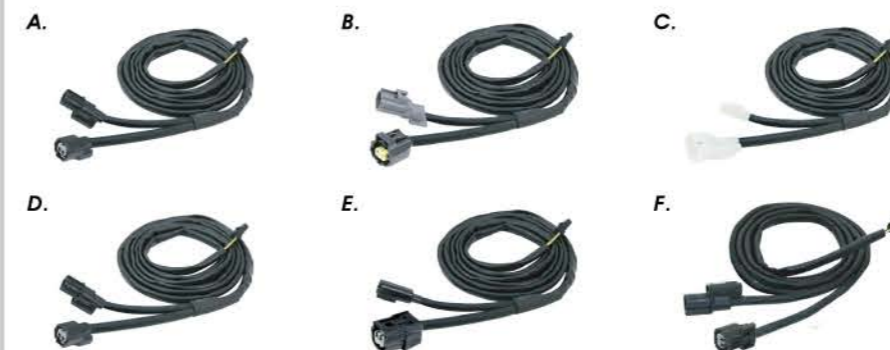

### Adapter wire for A/F ratio

Type	Item number
<b>A.</b> YAMAHA - CYGNUS.BWS.RS	* B 0 0 0 3 2 0 0 *
<b>B.</b> YAMAHA - MIO.NEW CUXI	* B 0 0 0 3 3 0 0 *
<b>C.</b> SYM & KYMCO	* B 0 0 0 3 2 0 1 *
<b>D.</b> SUZUKI - V125	* B 0 0 0 3 2 0 2 *
<b>E.</b> HONDA - PCX.GROM	* B 0 0 0 3 2 0 3 *

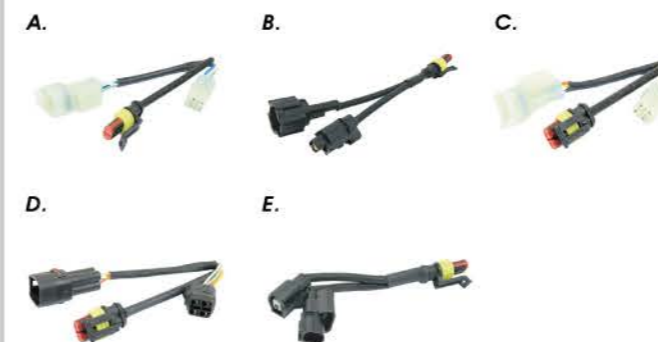

### Main wire

Model	Item number
<b>A.</b> RX2N	* B 0 0 1 5 0 0 0 *
<b>B.</b> RX2N, RX2	* B 0 0 1 1 0 0 0 *
<b>C.</b> DB-01R	* B 0 0 1 8 0 0 0 *

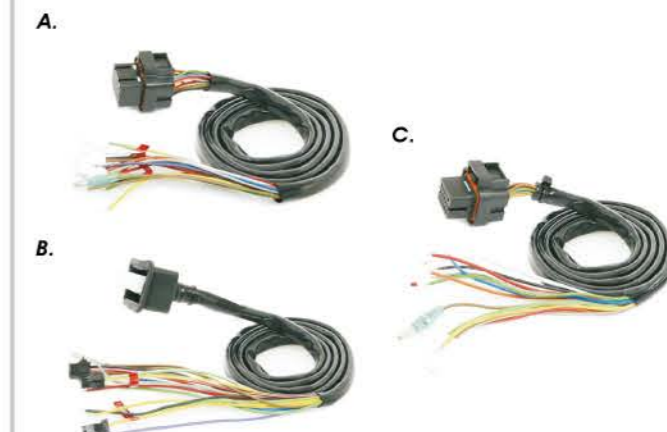

## Wire Harness



**Temp Sensor wire set (JST TYPE)**

Size	Item number
105 mm	* B 0 0 0 1 0 0 1 *



**Temp Sensor wire set**

Size	Item number
1 M	* B 0 0 0 1 0 0 *
2 M	* B 0 0 0 2 0 0 *



**RPM wire set (Type A)**

Item number
* B 0 0 0 1 A 0 0 *



**RPM wire set (Type B)**

Item number
* B 0 0 0 1 B 0 0 *



**RPM wire set (Type A)**

Item number
* B 0 0 0 1 A 0 1 *



**RPM wire set (Type B)**

Item number
* B 0 0 0 1 B 0 1 *



**RPM wire set (Type A)**

Item number
* B 0 0 0 1 A 0 2 *



**RPM wire set (Type C)**

Item number
* B 0 0 0 1 C 0 0 *



**Speed sensor extension wire set**

Size	Item number
100 mm	* B 0 0 0 5 0 0 *



**Shift light**

Size	Item number
D48 mm	* B J 4 8 0 R 0 0 *
D55 mm	* B J 5 5 0 R 0 0 *



**Battery box**

Size	Item number
UNIVERSAL	* Q 0 0 0 1 0 0 *



**Connect terminal**

Item number
* Q H 0 0 1 R 0 0 *

## Switches



**Fog light switch (For 7/8 & 1 inch)**

Type	Item number
Handlebar	* K B 0 0 2 0 0 0 *



**CNC Dual buttons switch (For 7/8 & 1 inch)**

Connector	Item number
A. water-proof connector	* K B 0 0 7 0 0 0 *
B. 3 Pin connector	* K B 0 0 7 0 1 0 *
no connector	* K B 0 0 7 0 2 0 *



**CNC switch (For 7/8 & 1 inch)**

Connector	Item number
A. water-proof connector	* K B 0 0 3 0 0 0 *
B. 3 Pin connector	* K B 0 0 3 0 1 0 *
no connector	* K B 0 0 3 0 2 0 *



**HANDLE BAR TYPE SINGLE**

Size	Item number
water-proof	* B 0 0 0 2 0 0 1 1 *



**HANDLE BAR TYPE DUAL**

Size	Item number
water-proof	* K B 0 0 9 0 0 0 *



**Fog light switch**

Type	Item number
Stick-On	* K B 0 0 0 0 0 0 *

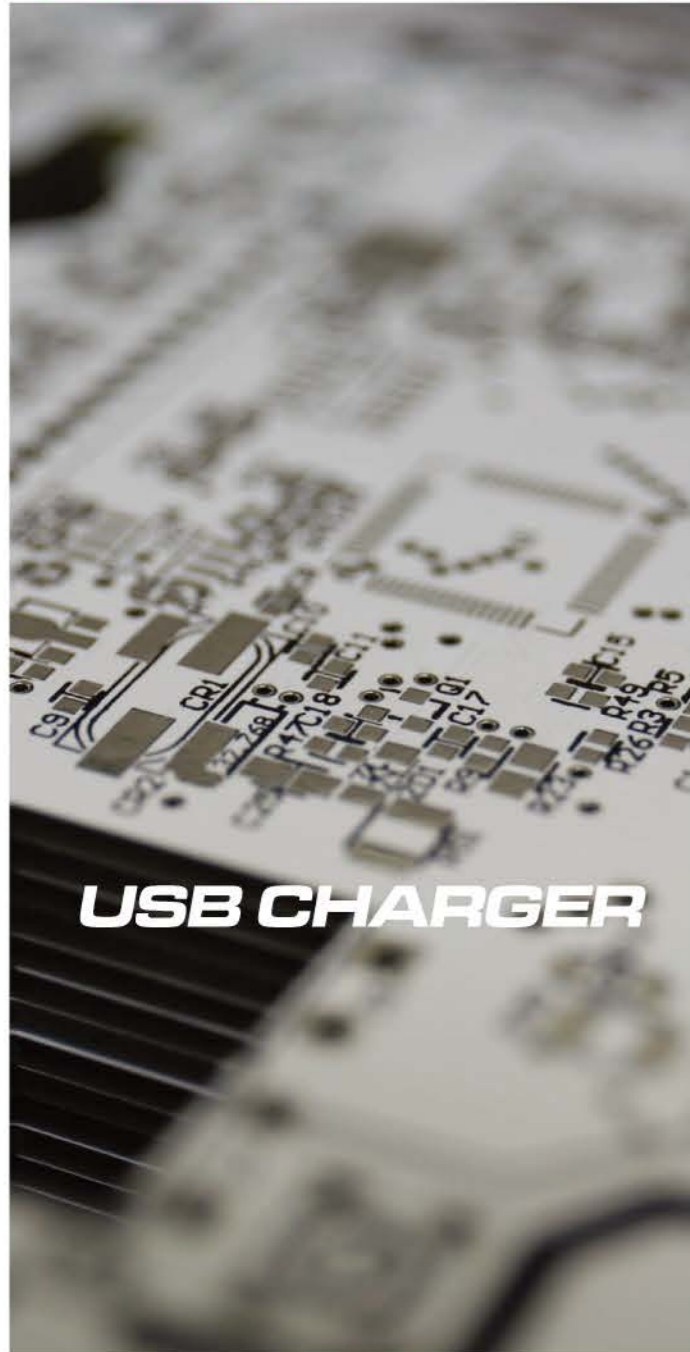

**Dual Port USB Charger (2A)**

Automatic power off	Item number
11.5 V	* K 0 0 0 8 1 0 0 *
12.5 V	* K 0 0 0 8 1 1 0 *
12.5 V	* K 0 0 0 8 0 0 0 *

(for Harley-Davidson)

**USB Charger (2A)**

Automatic power off	Item number
11.5 V	* K 0 0 0 9 0 0 0 *

**Dual Port USB Charger (support quick charge)**

Automatic power off	Feature	Item number
11.5 V	QC 3.0	* K 0 0 1 2 0 0 0 *

## USB Charger

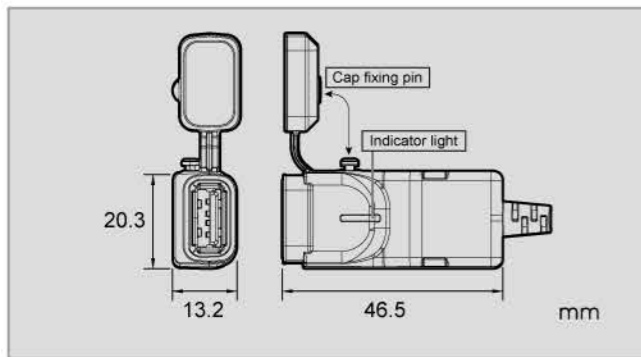

### USB Charger

Automatic power off	Feature	Item number
11.5 V	QC 3.0	*K W 0 0 2 0 0 3 *
11.5 V	TYPE C	*K W 0 0 5 0 0 0 *

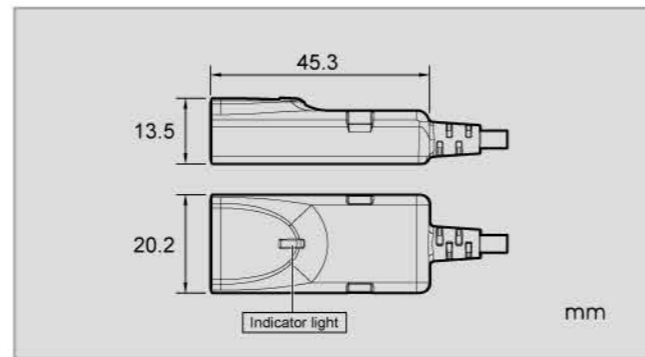

### USB Charger

Automatic power off	Feature	Item number
11.5 V	QC 3.0	*K W 0 1 0 0 0 0 *
11.5 V	TYPE C	*K W 0 0 9 0 0 0 *

NEW !

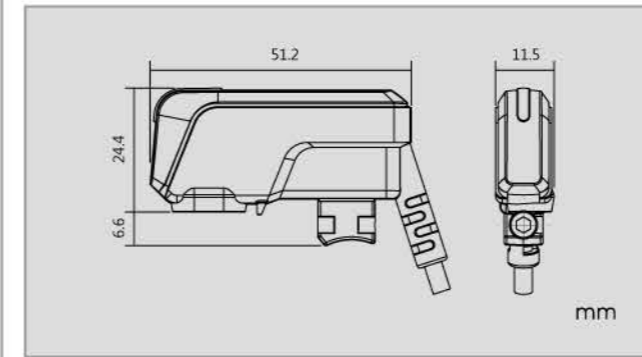

### Type C Charger - Single Port

Automatic power off	Feature	Item number
11.5 V	TYPE C	*K W 0 1 1 0 0 0 *

NEW !

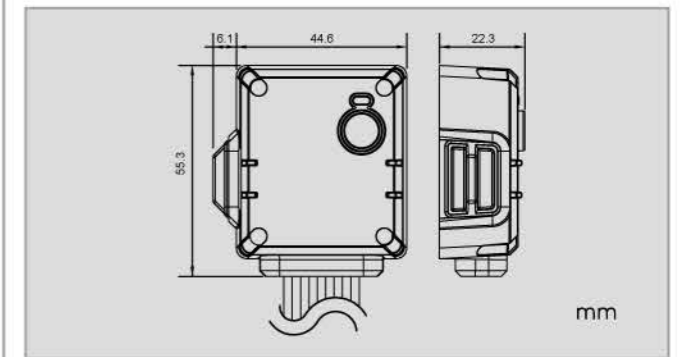

### ACC. Power Supply Extensioner

Automatic power off	Item number
11.5 V	*K K 0 2 0 0 0 0 *



## USB Charger

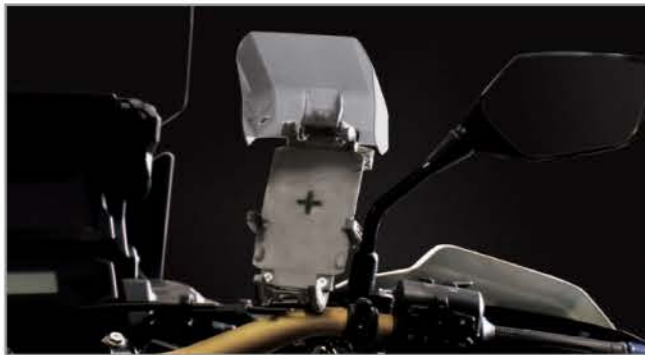

### **ARMOR Phone Holder** (wireless charger)

Automatic power off  
12.5 V

Item number



\* 4 R 0 0 5 0 0 0 \*



## Integrated Heated Grips



Finished are the days of searching around for a dial or button to power on heated grips. Our Titan-X heated grips for Harley-Davidson® feature an integrated 5 temperature level thumb switch which allows riders to easily power on/off or adjust the level of temperature without having to remove their hands from the handlebars. \* Fits 1" + 1" handlebar



### TITAN-X (for Harley-Davidson)

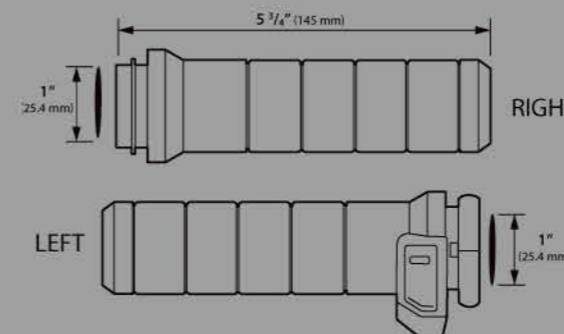

#### Body

Electronic Throttle - Black  
 Electronic Throttle - Chrome  
 Cable Throttle - Black  
 Cable Throttle - Chrome

#### Item number

\* A X D 6 8 K 0 0 \*  
 \* A X D 6 8 M 0 0 \*  
 \* A X D 6 8 K 1 0 \*  
 \* A X D 6 8 M 1 0 \*

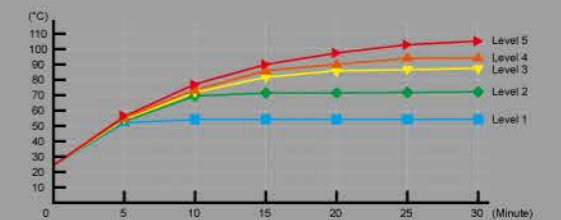

Integrated Heated Grips



**APOLLO-X** (for Harley-Davidson)

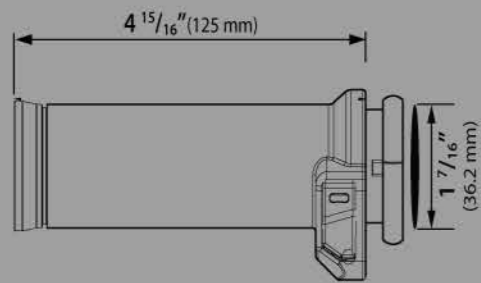

Body	Item number
Electronic Throttle - Black	* A X 1 1 8 0 I O *
Cable Throttle - Black	* A X 1 1 8 2 I O *

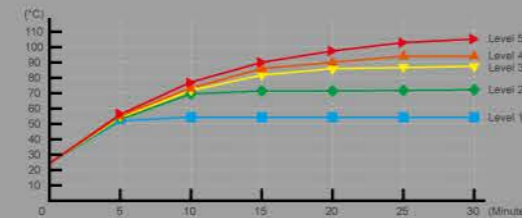

**ARTEMIS** *NEW!*

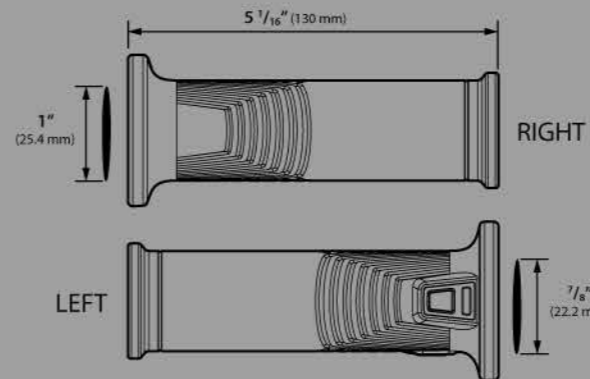

Size	Item number
7/8" + 1" L120mm	* A X 1 7 0 0 I O *
7/8" + 1" L130mm	* A X 1 7 1 0 I O *

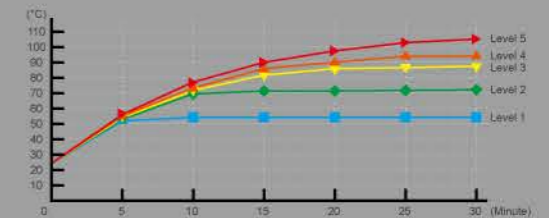

**Integrated Heated Grips**



**HG-14**



**APOLLO II** *NEW!*

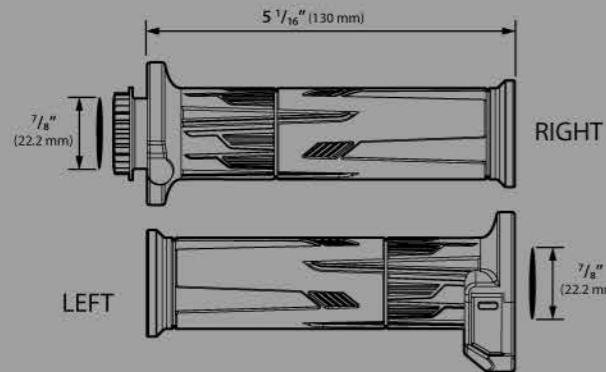

Size	Item number
7/8" + 7/8" L120mm	* A X 0 8 0 0 I O *
7/8" + 7/8" L130mm	* A X 0 8 1 0 I O *

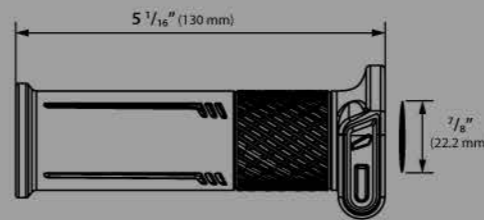
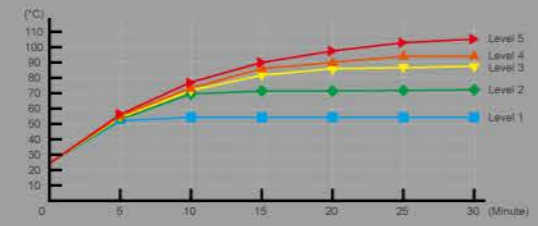

Size	Item number
7/8" + 1" L120mm	* A X 1 8 0 0 L O *
7/8" + 1" L130mm	* A X 1 8 1 0 L O *

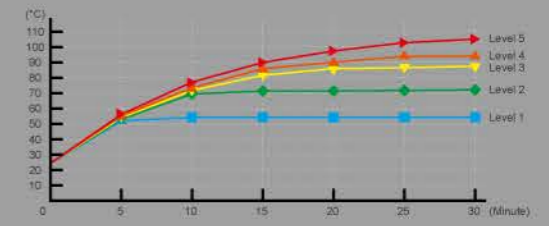

# Integrated Heated Grips



**HG-13**



**APOLLO**

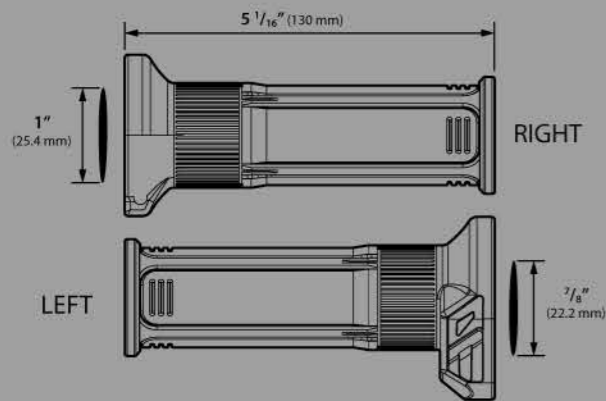

Size	Item number
7/8" + 1" L120mm	* A X 0 4 1 0 I 0 *
7/8" + 1" L130mm	* A X 0 4 1 1 I 0 *

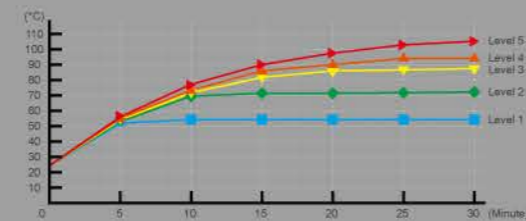

Size	Item number
7/8" + 1" L120mm	* A M 1 1 1 0 1 0 *
7/8" + 1" L130mm	* A M 1 1 1 0 3 0 *

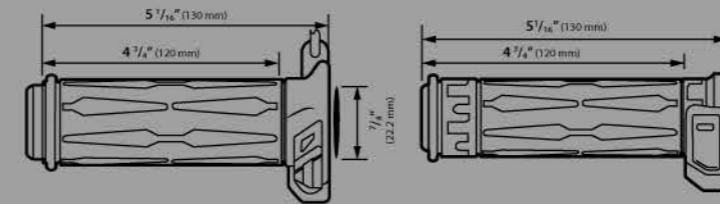

**For ATV / Snowmobile**

Size	Item number
7/8" + 7/8" L130mm	* A X 0 7 3 0 I 0 *
7/8" + 7/8" L130mm (with heated thumb)	* A X 0 7 3 2 I 0 *

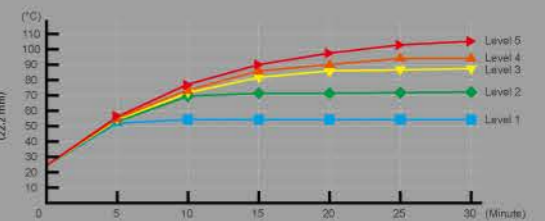



**HG-03N**

*Item number*

1 600 001 0000 1 600 001 0000 1 600 001 0000  
\* A M 1 0 3 \*

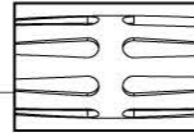

**HG-04N**

*Item number*

1 600 001 0000 1 600 001 0000 1 600 001 0000  
\* A M 1 0 4 \*

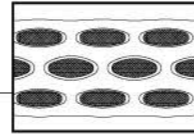

**HG-05N**

*Item number*

1 600 001 0000 1 600 001 0000 1 600 001 0000  
\* A M 1 0 5 \*

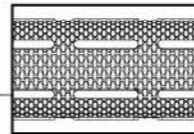

**HG-07**

*Item number*

1 600 001 0000 1 600 001 0000 1 600 001 0000  
\* A M 1 0 7 \*

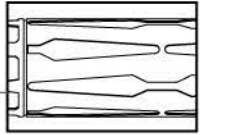

**HG-08**

*Item number*

1 600 001 0000 1 600 001 0000 1 600 001 0000  
\* A M 1 0 8 \*

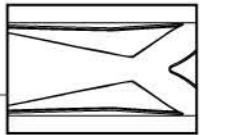

**HG-09**

*Item number*

1 600 001 0000 1 600 001 0000 1 600 001 0000  
\* A M 1 0 9 \*

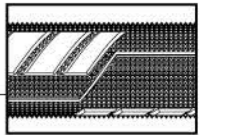



**HG-11**

*Item number*

1 600 001 000 001 000 000 000 000 000 000  
\* A M 1 9 0 \*

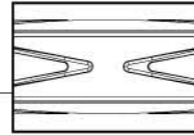

**HG-12**

*Item number*

1 600 001 000 001 000 000 000 000 000  
\* A M 1 1 3 \*

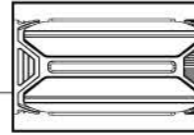

**HG-13**

*Item number*

1 600 001 000 001 000 000 000 000 000  
\* A X 0 4 1 \*

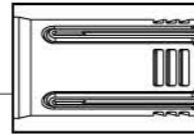

**TITAN**

*Item number*

1 600 001 000 001 000 000 000 000 000  
\* A X 0 6 5 \*

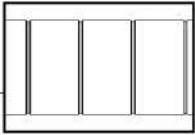

**HG-14**

*Item number*

1 600 001 000 001 000 000 000 000 000  
\* A X 0 8 0 \*

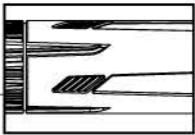

**HG-15**

*Item number*

1 600 001 000 001 000 000 000 000 000  
\* A X 0 9 0 \*

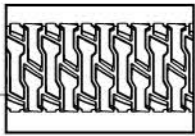

**SNOW/DIRT BICYCLE**



**MX-1**

Item number

\* AX 1 3 0 \*

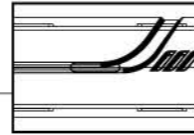

**BICYCLE**



**HB-01**

Item number

\* AX 1 0 7 \*

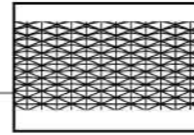

**NEW !**

**X-CLAWS II**

Item number

\* AX 1 9 0 0 \*

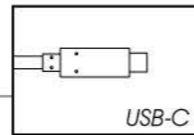

Item number

\* AX 1 9 0 1 \*

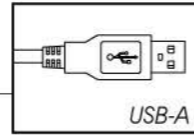

**X-CLAWS**

Item number

\* AX 1 2 0 0 M 0 \*

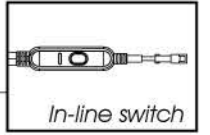

Item number

\* AX 1 2 0 0 0 0 \*

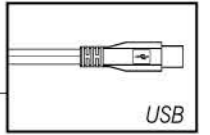

**REMOVABLE**

Item number

\* AM 1 1 2 0 0 0 \*



**HEATED GLOVES**

Item number

\* QS 0 0 3 0 0 0 \*



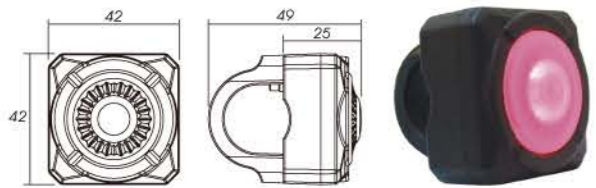

# Heater Grip Switches

**D type**  \*AF101000\*

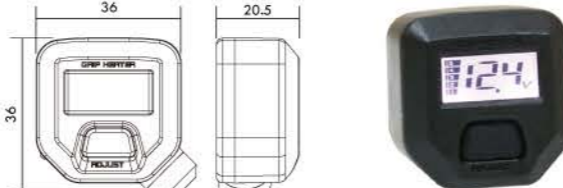

**H type**  \*AF190000\*



**Switch with QC 3.0 Charger**  \*KB011100\*



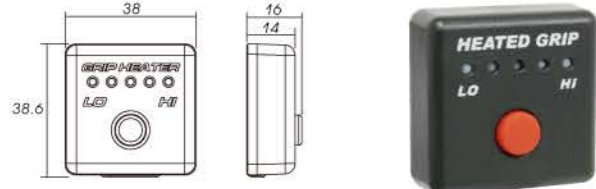

**E type**  \*AF003K00\*

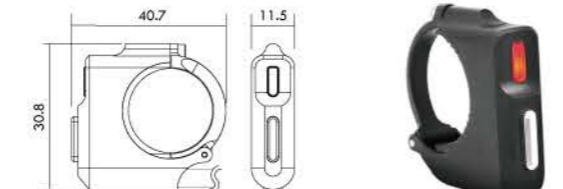

**J type**  \*KB005000\*



**Switch with Type C Charger**  \*KB011000\*



**F type**  \*AF000K01\*

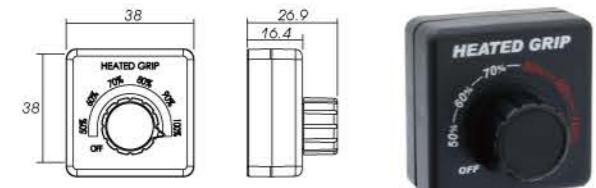

**K MK II type**  \*KB010000\*



**THUMB HEATER KIT**  \*AM00001B\*



**G type**  \*AF113000\*



**IN-LINE HI/LO SWITCH**

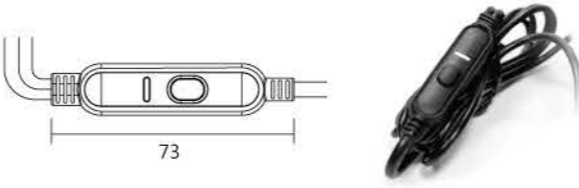

# LED HEADLIGHT



## GH01 *NEW!*

Presenting the newest addition to our headlight lineup: the GH01 LED headlight. Perfect for any bike, this new universal headlight is E-Mark, DOT and SAE certified. The GH01's LED light design will not only give a great look to your motorcycle, but its powerful LED lights will also allow you to drive safely all throughout the day and night.

### Specifications

- Class D brightness level
- Voltage:
  - Front position: DC 12V / 1.9W
  - DRL: DC 12V / 14.1W
  - Low beam: DC 12V / 18W
  - High beam: DC 12V / 33.7W
- Brightness:
  - Low beam: 1621 lumens
  - High beam: 2703 lumens
- E-mark and DOT compliant



DRL + Front Position



Low Beam



High Beam

Body Color	Lens	Item number
Black	Clear	6A034000

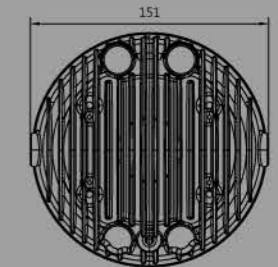
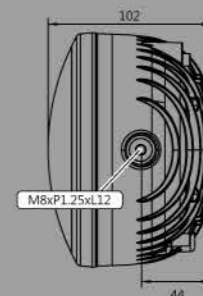

mm



**Specifications**

- Class D brightness level
- Voltage:
  - Front position: DC 12V / 2.7W
  - Low beam: DC 12V / 24.9W
  - High beam: DC 12V / 20.2W
- Brightness:
  - Low beam: 1889 lumens
  - High beam: 1557 lumens
- E-mark and DOT compliant



Low Beam High Beam

**ZENITH** *NEW!*

The Zenith LED headlight is perfect for any bike, this new universal headlight features a lightweight, durable die-cast housing and is also DOT and SAE certified. The Zenith's LED light design will not only give a great look to your motorcycle, but its powerful LED lights will also allow you to drive safely all throughout the day and night.

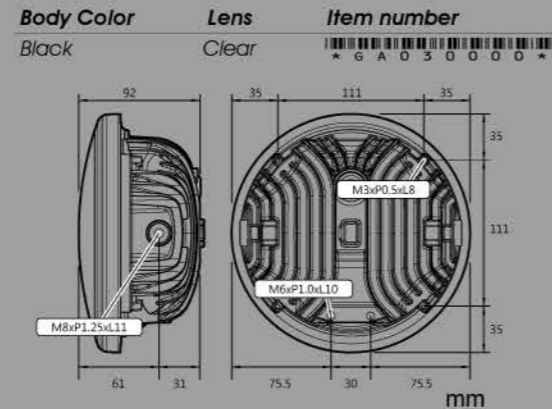

**Specifications**

- Class D brightness level
- Voltage:
  - Front position: DC 12V / 5W
  - Low beam: DC 12V / 15W
  - High beam: DC 12V / 22W
- Brightness:
  - Low beam: 1319 lumens
  - High beam: 2089 lumens
- E-mark and DOT compliant



Low Beam High Beam

**THUNDERBOLT EVO**

A brighter headlight means more security, this is the reason why Koso decided to release its new Thunderbolt LED headlight. This headlight features a light weight but durable aluminium housing and is one of the only headlights on the market today to be produced using CNC technology. This headlight is universal meaning it can fit virtually any bike and is also DOT certified.

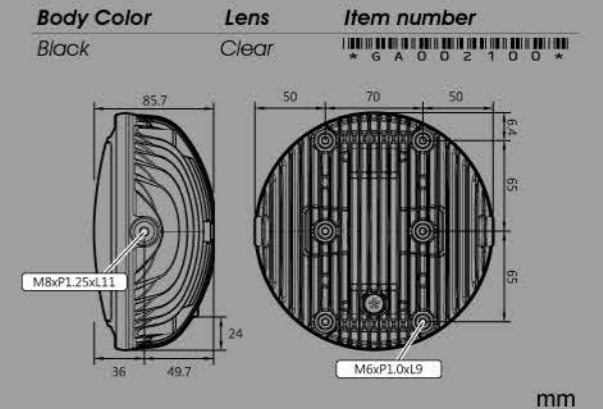

mm



**Specifications**

- Class B brightness level
- Voltage:
  - Front position: DC 13.5V / 0.8W
  - Low beam: DC 13.2V / 14.7W
  - High beam: DC 13.2V / 7.3W
- Brightness:
  - Low beam: 508 lumens
  - High beam: 1007 lumens
- E-mark and DOT compliant



Low Beam



High Beam

**H001 LED HEADLIGHT**

The H001 LED headlight give an awesome custom look while providing powerful LED brightness. These headlights features a light weight and durable CNC aluminium housing that can be installed on virtually any application. E-Mark and DOT certified.

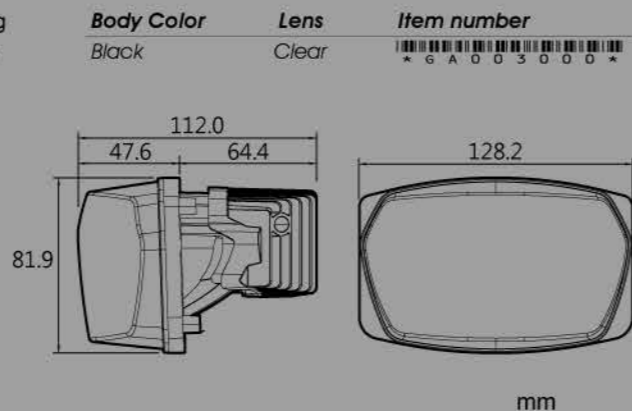

**HAWKEYE**

The new Hawkeye dual headlight give an awesome custom look while providing powerful LED brightness. These headlights features a light weight and durable CNC aluminium housing that can be installed on virtually any application. E-Mark and DOT certified.

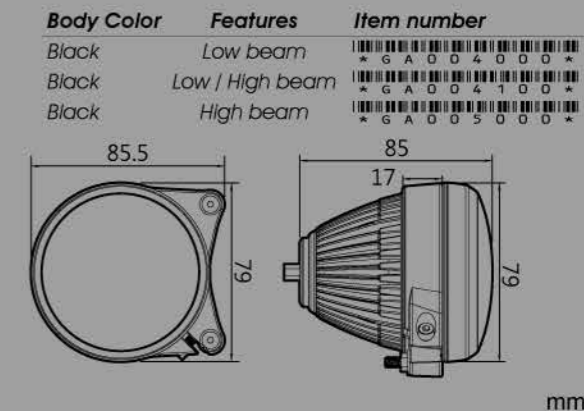

**Specifications**

- Class D brightness level
- Voltage:
  - Low beam: DC 12V / 14W
  - High beam: DC 12V / 14W
- Brightness:
  - Low beam: 1058 lumens
  - High beam: 813 lumens
- E-mark and DOT compliant





**Specifications**

- Class D brightness level
- Voltage:
  - Low beam: DC 12V / 11.2W
  - High beam: DC 12V / 9.6W
- Brightness:
  - Low beam: 1129.8 lumens
  - High beam: 879.5 lumens
- E-mark compliant



**MINI LED HEADLIGHT**

Body Color	Features	Item number
Black	Low beam	* 6 A 0 3 2 0 0 0 *
Black	High beam	* 6 A 0 3 2 1 0 0 *

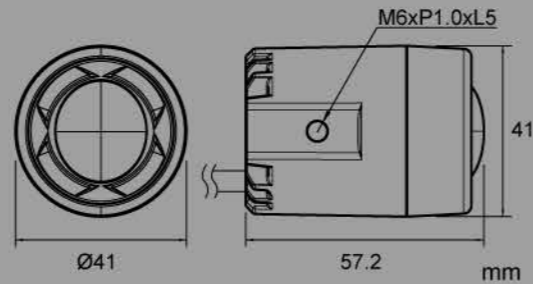
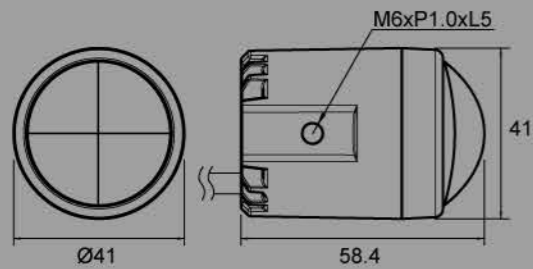



# LED Fog Light Aurora



**Body Size**

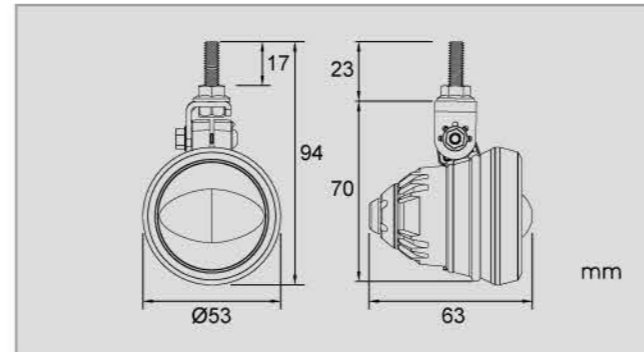

**Aurora fog light**

Body Color	Lens	pcs.	Accessories	Item number
Black	Clear	1	Frame	* H 6 0 0 8 0 0 0 *
Black	Clear	2	Frame / Switch / DRL Mounting System*	* H 6 0 0 8 0 0 1 *
Black	Clear	1	Switch / Switch	* H 6 0 0 8 0 1 0 *

**Option accessory**

**1** Fog light switch





**2** Fog light switch

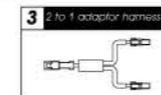

**3** 2 to 1 adaptor harness





**Body Size**

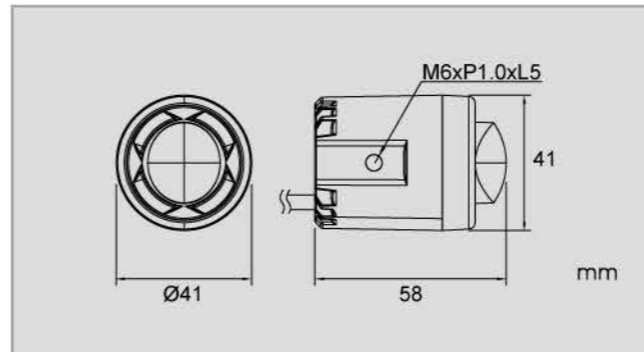

**Mini fog light**

Body Color	Lens	pcs.	Accessories	Item number
Black	Clear	1	Frame	* H 6 0 1 0 0 0 0 *

**Option accessory**

**1** Fog light switch





**2** Fog light switch

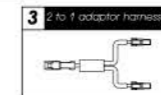

**3** 2 to 1 adaptor harness





**Body Size**

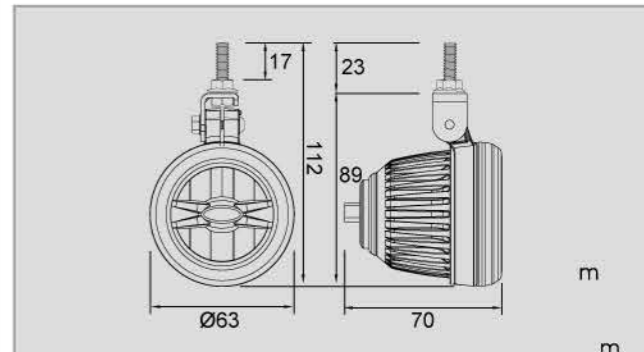

**Star fog light**

Body Color	Lens	pcs.	Accessories	Item number
Black	Clear	1	Frame	* H 6 0 0 9 0 0 0 *

**Option accessory**

**1** Fog light switch



**2** Fog light switch



**3** 2 to 1 adaptor harness

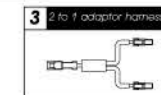

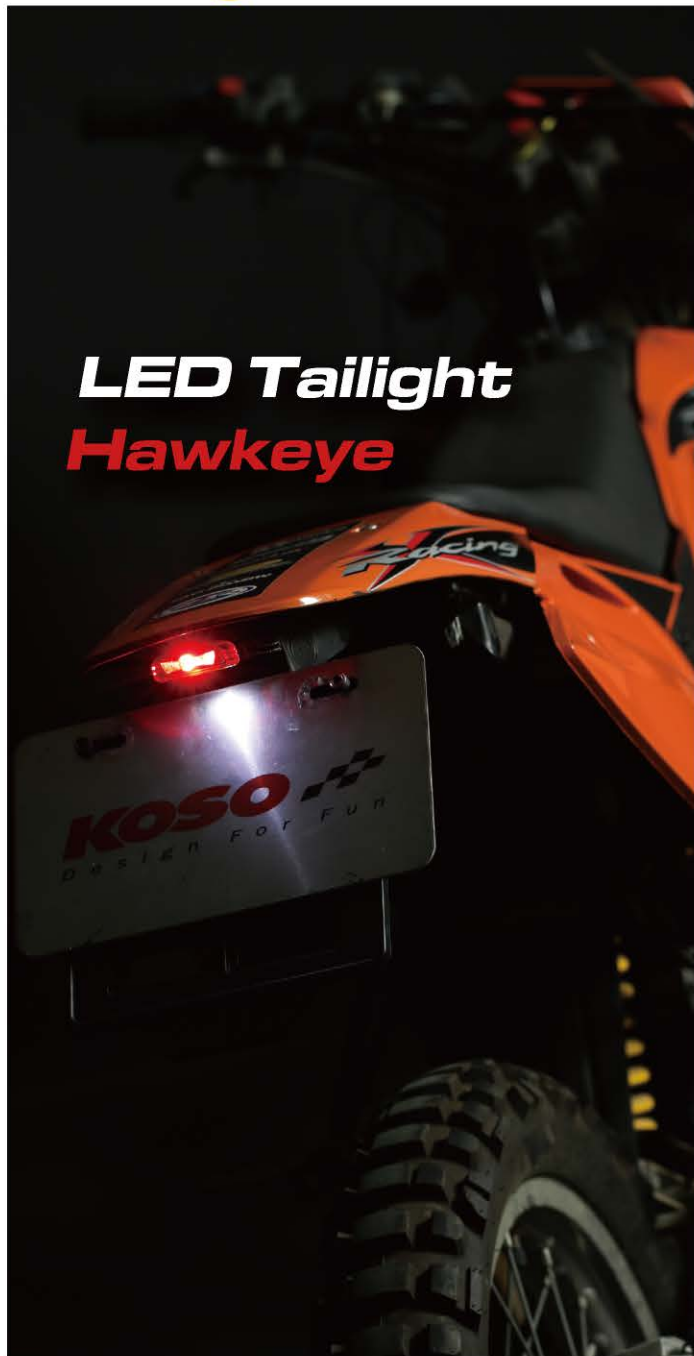

# LED Taillight Hawkeye

**Body Size**

50.2  
17  
24  
mm

**Hawkeye**

Body Color	Lens	Item number
Black	Red	* H B 0 3 4 0 0 0 *
Black	Smoke	* H B 0 3 4 0 1 0 *

**Body Size**

99.7  
31.5  
35.6  
mm

**Mini 2**

Body Color	Lens	Item number
Black	Red	* H B 0 3 7 0 0 0 *
Black	Smoke	* H B 0 3 7 0 1 0 *

**Body Size**

101  
32.5  
31.9  
mm

**Infinity**

Body Color	Lens	Item number
Black	Smoke	* H B 0 2 5 0 1 0 *
Black	Red	* H B 0 2 5 0 2 0 *

## LED Taillight



### Body Size

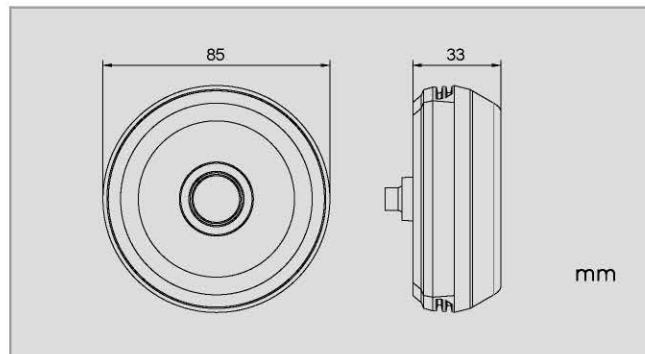

### Solar

Body Color	Lens	Item number
Black	Clear	* H B 0 3 5 0 0 0 *
Black	Smoke	* H B 0 3 5 0 1 0 *
Black	Red	* H B 0 3 5 0 2 0 *



### Body Size

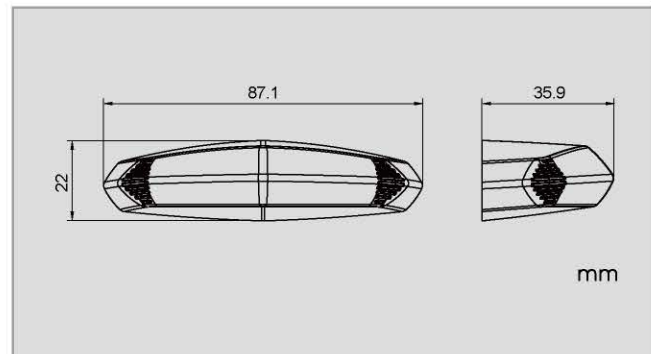

### GT-01

Body Color	Lens	Item number
Black	Red	* H B 0 3 1 0 0 0 *
Black	Smoke	* H B 0 3 1 1 0 0 *



### Body Size

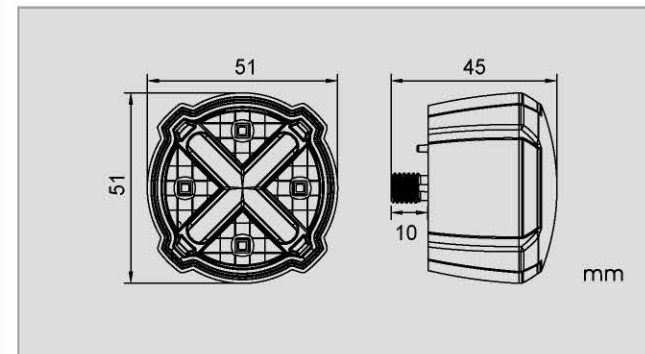

### GT-02

Body Color	Lens	Item number
Black	Red	* H B 0 3 6 0 0 1 *
Black	Smoke	* H B 0 3 6 1 0 1 *



### Body Size

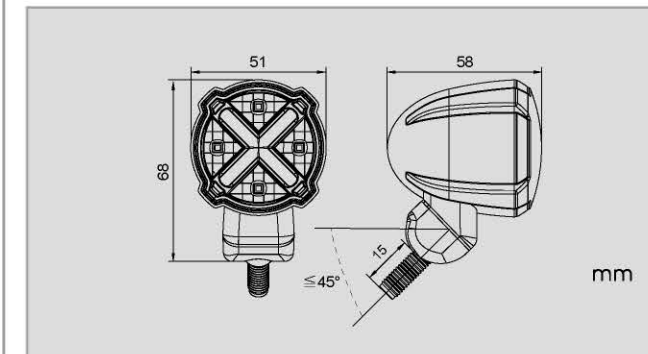

### GT-02S

Body Color	Lens	Item number
Black	Red	* H B 0 3 6 0 0 0 *
Black	Smoke	* H B 0 3 6 1 0 0 *



# LED Taillight



### Body Size

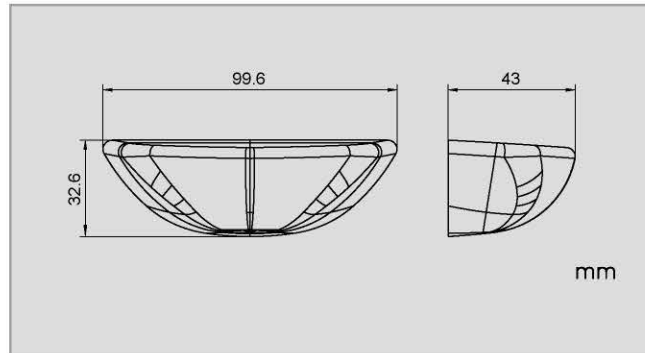

### GT-03

Body Color	Lens	Item number
Black	Red	* H B 0 3 8 0 0 0 *
Black	Smoke	* H B 0 3 8 1 0 0 *



### Body Size

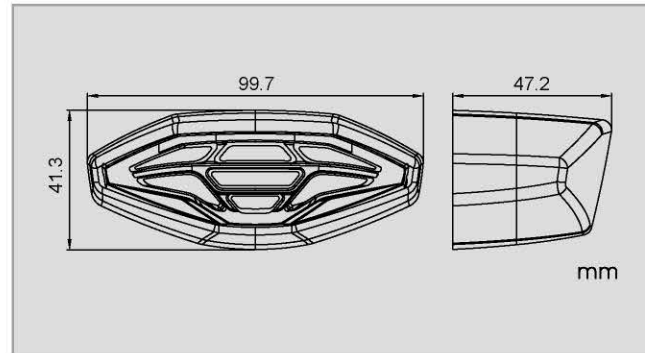

### GT-04

Body Color	Lens	Item number
Black	Smoke	* H B 0 3 9 0 0 0 *



### Body Size

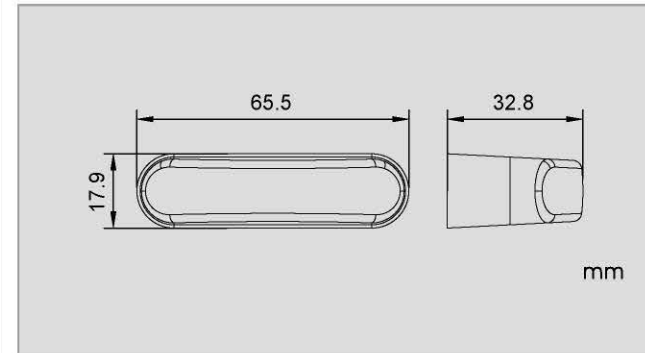

### GT-05

Body Color	Lens	Item number
Black	Smoke	* H B 0 4 0 0 0 0 *



### Body Size

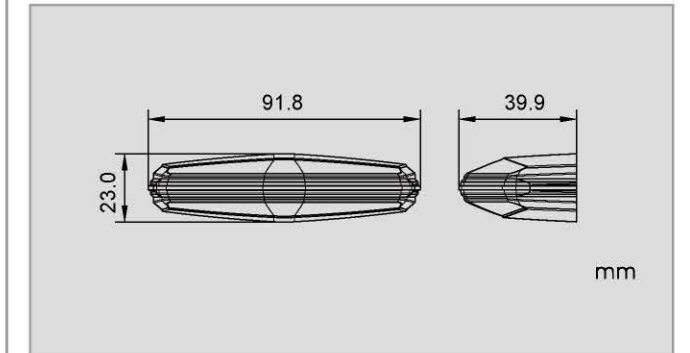

### GT-06

Body Color	Lens	Item number
Black	Red	* H B 0 4 1 0 0 0 *
Black	Smoke	* H B 0 4 1 1 0 0 *

## LED Taillight



### Body Size

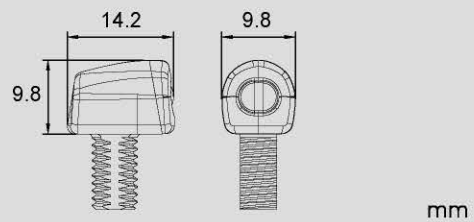

### Nano

Body Color	Lens	Item number
Black	Clear	 * H E 0 4 1 2 0 0 *



License Plate Light



---

**Body Size**

**Blade**

Body Color	Lens	Item number
Black	Black	* H b 0 0 8 0 0 0 *

---

**Body Size**

**Speed II**

Body Color	Lens	Item number
Black	Clear	* H b 0 0 9 2 0 0 *

---

**Body Size**

**Curve**

Body Color	Lens	Item number
Black	Clear	* H b 0 1 0 0 0 0 *

# License Plate Light



## Body Size

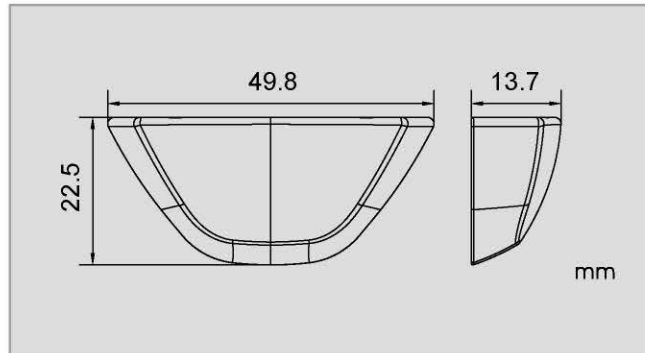

### GL-01

Body Color	Lens	Item number
Black	Clear	 * H B 0 1 1 0 0 0 *



## Body Size

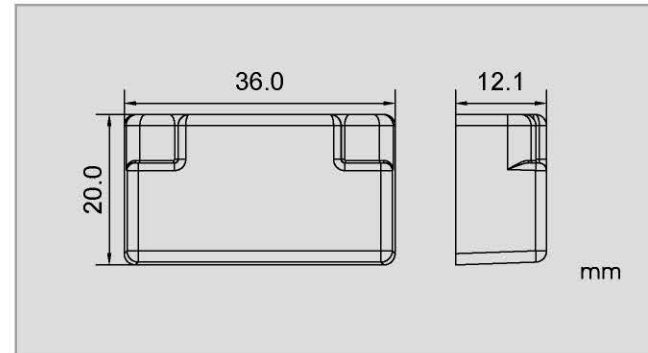

### GL-02

Body Color	Lens	Item number
Black	Clear	 * H B 0 1 2 0 0 0 *



## Body Size

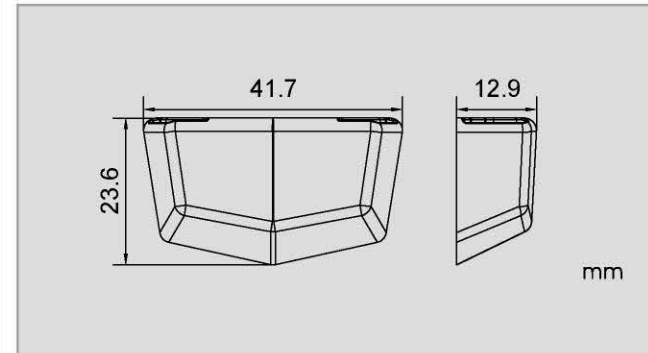

### GL-03

Body Color	Lens	Item number
Black	Clear	 * H B 0 1 2 1 0 0 *



## Body Size

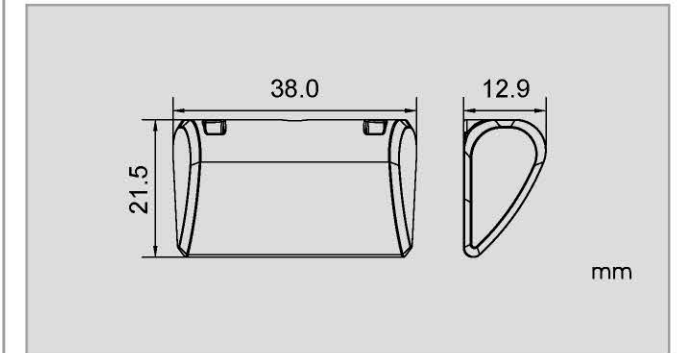

### GL-04

Body Color	Lens	Item number
Black	Clear	 * H B 0 1 2 2 0 0 *

Indicator Light



**VESPA**  
**INDICATOR**  
**LIGHT**

**NEW !**

E

**Body Size**

mm

**Primavera/Sprint-F**

Body Color	Lens	Item number
Black	Clear	HC915000*
Black	Smoke	HC915010*

**NEW !**

E

**Body Size**

mm

**Primavera/Sprint-R**

Body Color	Lens	Item number
Black	Clear	HC915100*
Black	Smoke	HC915110*

# Indicator Light

NEW !



Body Size

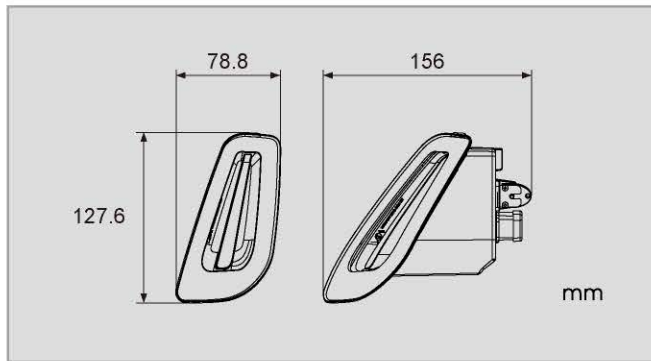

## LX-F

Body Color	Lens	Item number
Black	Clear	* H C 8 0 9 0 0 0 *
Black	Smoke	* H C 8 0 9 0 1 0 *

NEW !



Body Size

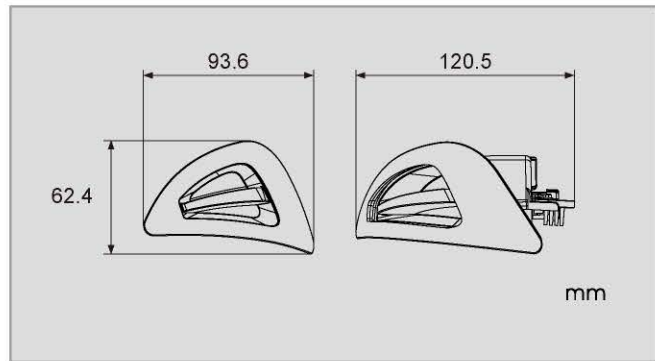

## LX-R

Body Color	Lens	Item number
Black	Clear	* H C 8 0 9 1 0 0 *
Black	Smoke	* H C 8 0 9 1 1 0 *

NEW !



Body Size

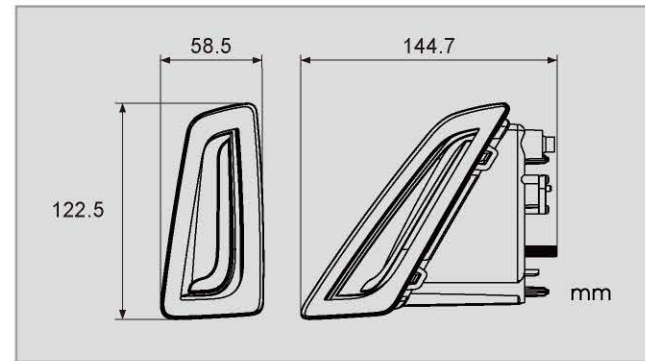

## GTS 300-F

Body Color	Lens	Item number
Black	Clear	* H C 8 0 8 0 0 0 *
Black	Smoke	* H C 8 0 8 0 1 0 *

NEW !



Body Size

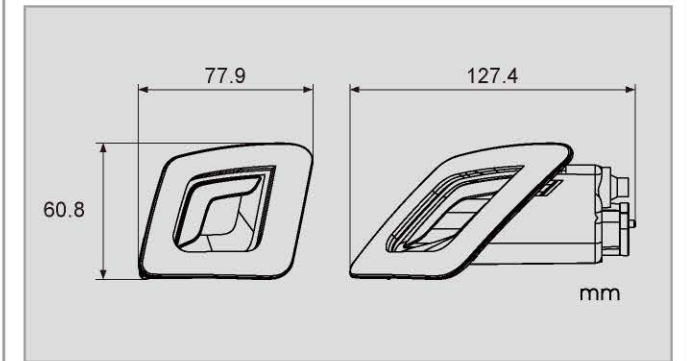

## GTS 300-R

Body Color	Lens	Item number
Black	Clear	* H C 8 0 8 1 0 0 *
Black	Smoke	* H C 8 0 8 1 1 0 *



## Indicator Light



Body Size

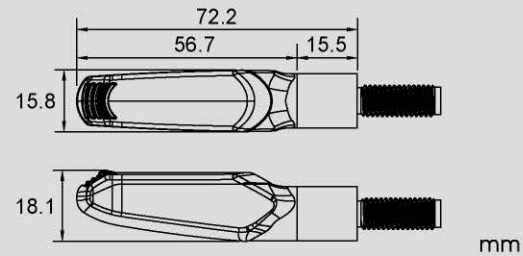

### GW01-D (Dynamic LED Indicator)

Body Color	Lens	pcs.	Item number
Black	Smoke	2	HE038001*
Black	Clear	2	HE038101*



Body Size

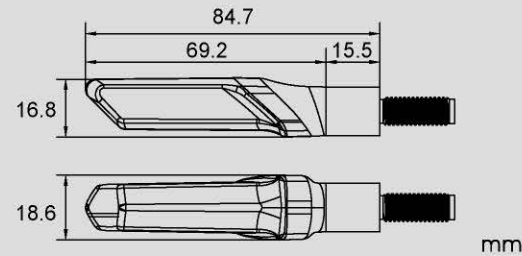

### GW02-D (Dynamic LED Indicator)

Body Color	Lens	pcs.	Item number
Black	Smoke	2	HE044000*
Black	Clear	2	HE044100*



Body Size

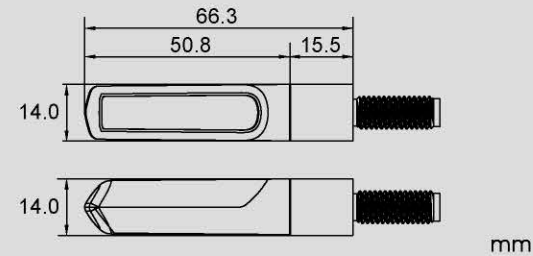

### Electro-D (Dynamic LED Indicator)

Body Color	Lens	pcs.	Item number
Black	Clear	1	HE037000*
Black	Smoke	1	HE037010*
Black	Amber	1	HE037020*



Body Size

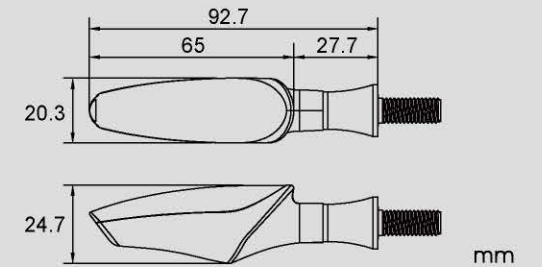

### Infinity-D (Dynamic LED Indicator)

Body Color	Lens	pcs.	Item number
Black	Clear	2	HE040001*
Black	Smoke	2	HE040101*

### Infinity

Body Color	Lens	pcs.	Item number
Black	Clear	2	HE030001*
Black	Smoke	2	HE030011*



## Indicator Light



Body Size

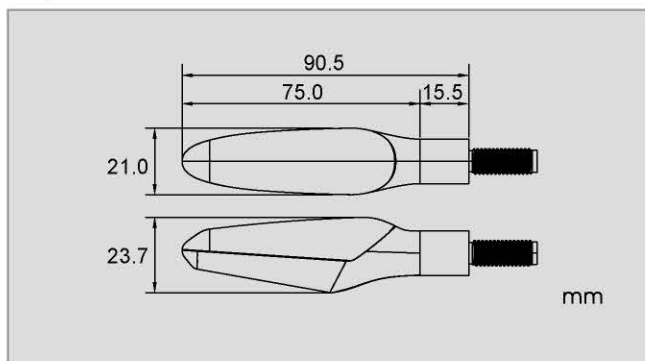

### Z4-D (Dynamic LED Indicator)

Body Color	Lens	pcs.	Item number
Black	Clear	2	HE046000



Body Size

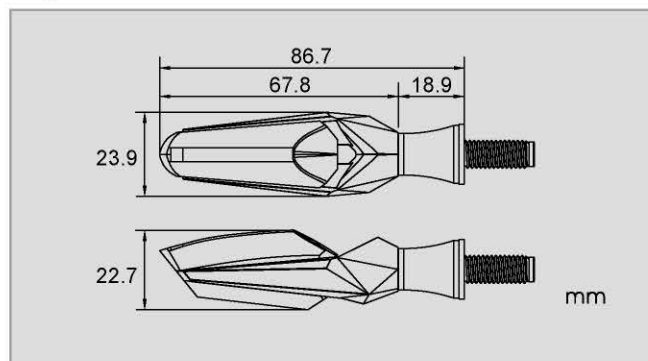

### Mars

Body Color	Lens	pcs.	Item number
Black	Clear	2	HE103K01
Black	Smoke	2	HE103K11
Silver	Clear	2	HE103S01



Body Size

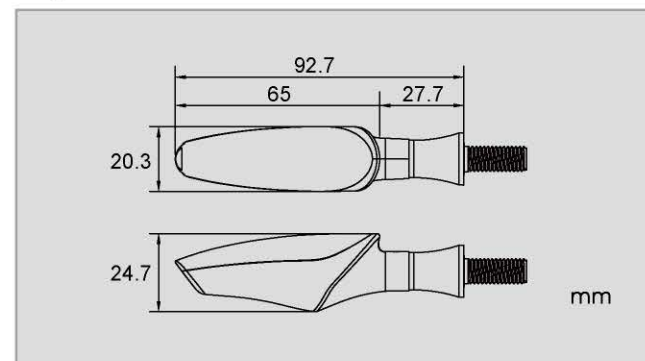

### Unlimited

Body Color	Lens	pcs.	Item number
Black	Clear	1	HE015KI0



Body Size

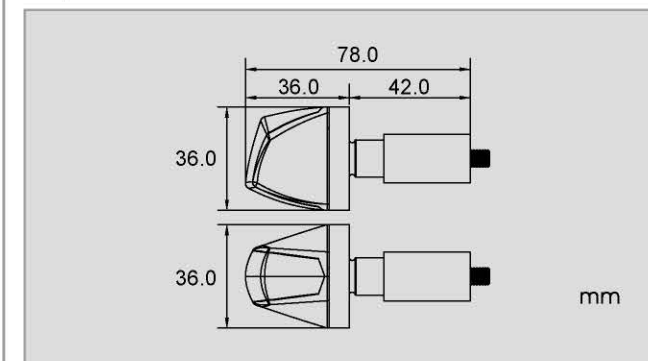

### Knight

Body Color	Lens	pcs.	Item number
Black	Clear	1	HE033000
Black	Smoke	1	HE033010

## Indicator Light



Body Size

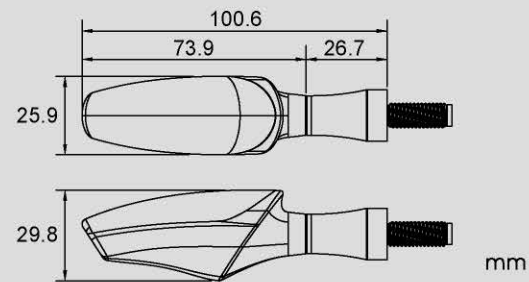

### Z2

Body Color	Lens	pcs.	Item number
Black	Clear	2	* H E 0 3 9 0 0 0 *
Black	Smoke	2	* H E 0 3 9 1 0 0 *



Body Size

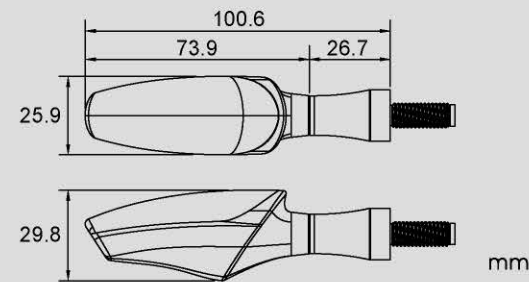

### Z3

Body Color	Lens	pcs.	Item number
Black	Smoke	2	* H E 0 3 9 2 0 0 *
Black	Clear	2	* H E 0 3 9 3 0 0 *



Body Size

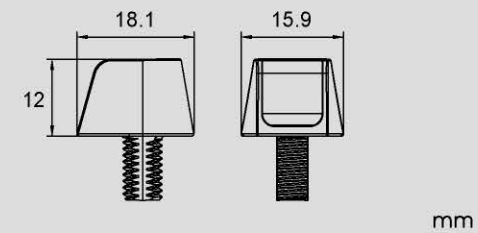

### Ion

Body Color	Lens	pcs.	Item number
Black	Clear	2	* H E 0 4 2 0 0 1 *



Body Size

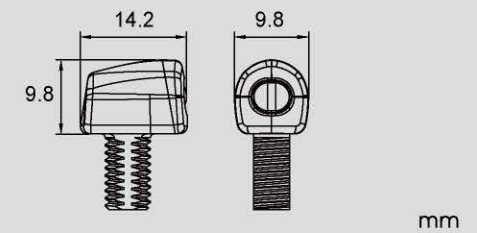

### Nano

Body Color	Lens	pcs.	Item number
Black	Clear	2	* H E 0 4 1 0 0 1 *

# Indicator Light

NEW!



Body Size

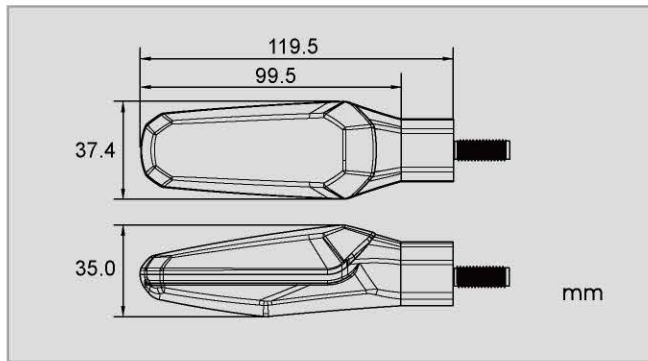

## Z5

Body Color	Lens	pcs.	Item number
Black	Smoke	2	*HE053000*
Black	Clear	2	*HE053100*

NEW!



Body Size

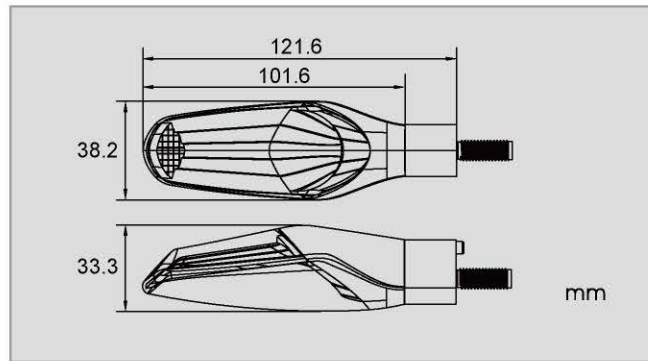

## NU

Body Color	Lens	pcs.	Item number
Black	Clear	2	*HE055000*



Body Size

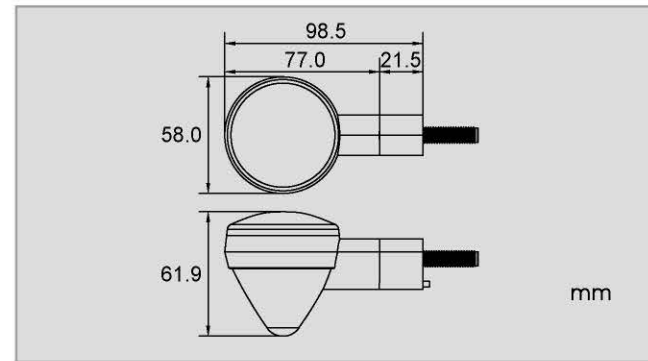

## Glare

Body Color	Lens	pcs.	Item number
Black	Clear	2	*HE031001*
Black	Smoke	2	*HE031011*
Black	Amber	2	*HE031021*



Body Size

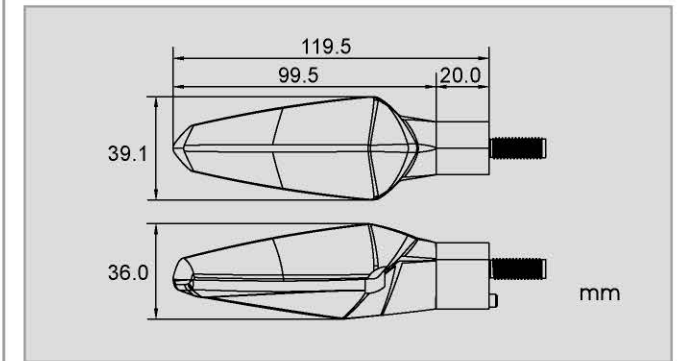

## Arrow

Body Color	Features	pcs.	Item number
Black	Clear	2	*HE032000*
Black	Smoke	2	*HE032010*
Black	Amber	2	*HE032020*

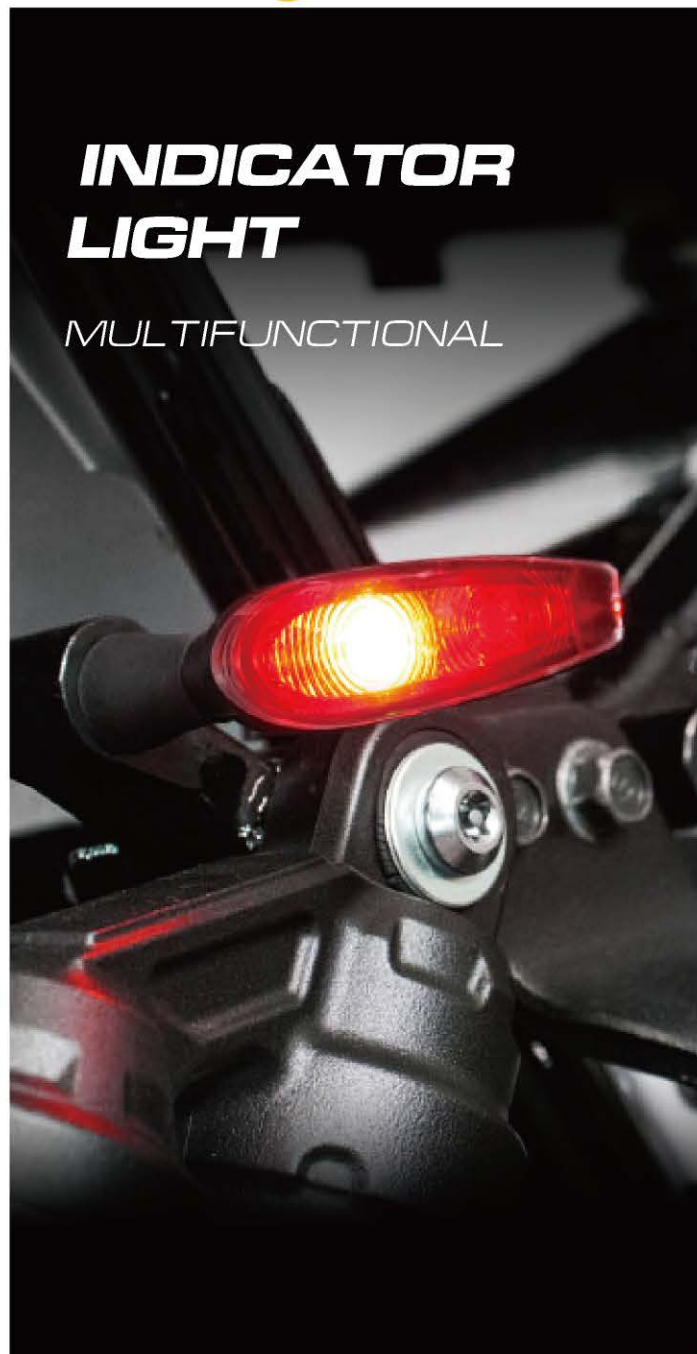

# INDICATOR LIGHT

MULTIFUNCTIONAL



Body Size

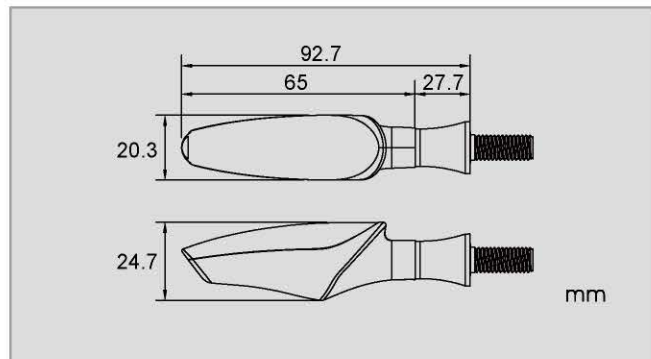

### Infinity-R (Winker/night & brake light)

Body Color	Lens	pcs.	Item number
Black	Clear	2	* H B 0 3 0 0 0 1 *
Black	Smoke	2	* H B 0 3 0 0 1 1 *

### Infinity-F (Winker & front position light)

Body Color	Lens	pcs.	Item number
Black	Clear	2	* H B 0 3 0 1 0 1 *
Black	Smoke	2	* H B 0 3 0 1 1 1 *

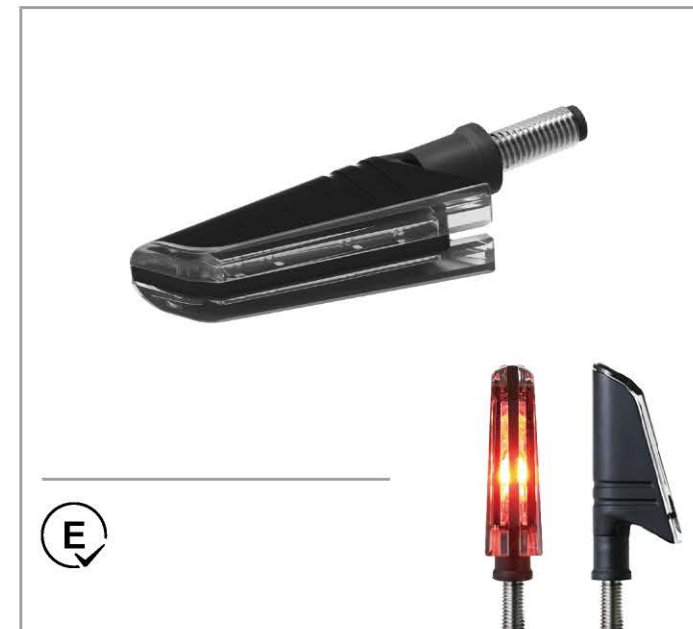

Body Size

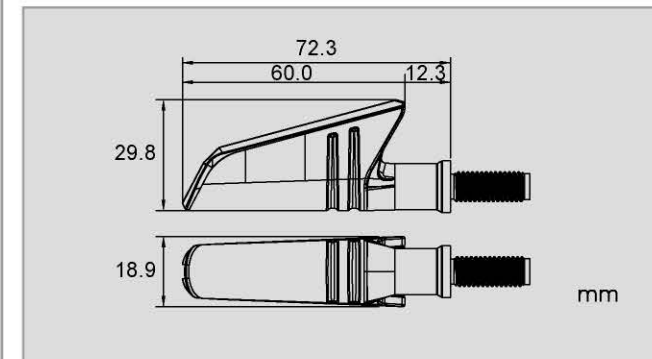

### Shadow-R (Winker/night & brake light)

Body Color	Lens	pcs.	Item number
Black	Clear	2	* H E 0 4 3 4 0 0 *

### Shadow

Body Color	Lens	pcs.	Item number
Black	Clear	2	* H E 0 4 3 0 0 0 *
Black	Smoke	2	* H E 0 4 3 1 0 0 *
Black	Amber	2	* H E 0 4 3 2 0 0 *



Body Size

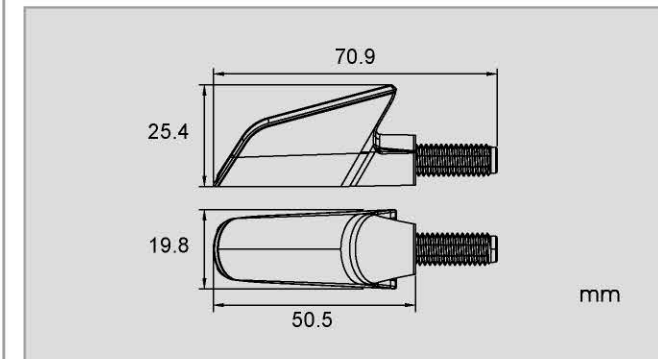

### Strike Mini

Body Color	Lens	pcs.	Item number
Sliver	Clear	1	* H E 0 4 8 0 0 0 *

## Indicator Light



Body Size

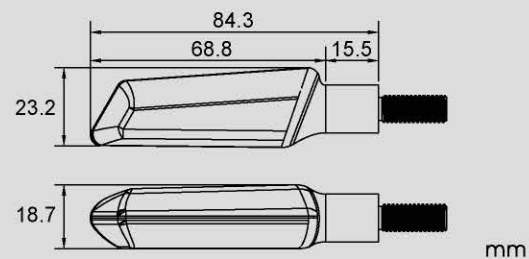

### GW03-R (Winker/night & brake light)

Body Color	Lens	pcs.	Item number
Black	Clear	2	*HE047000*

### GW03-F (Winker & front position light)

Body Color	Lens	pcs.	Item number
Black	Clear	2	*HE047100*



Body Size

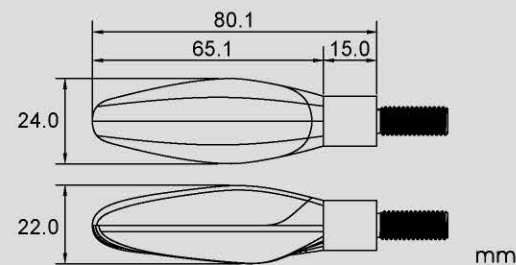

### Sonic-R (Winker/night & brake light)

Body Color	Lens	pcs.	Item number
Black	Clear	2	*HE045001*

### Sonic-F (Winker & front position light)

Body Color	Lens	pcs.	Item number
Black	Clear	2	*HE045201*



Body Size

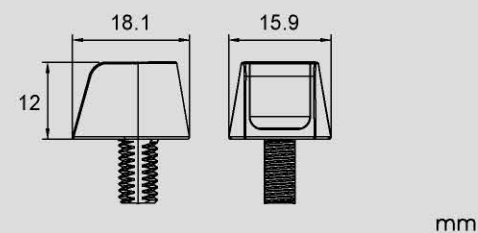

### Ion-R (Winker/night & brake light)

Body Color	Lens	pcs.	Item number
Black	Clear	2	*HE042101*



Body Size

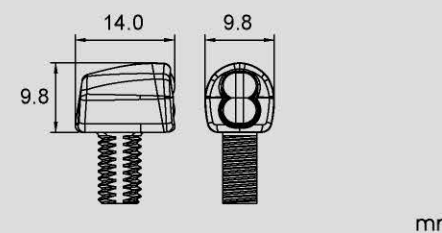

### Nano-R (Winker/night & brake light)

Body Color	Lens	pcs.	Item number
Black	Clear	2	*HE041101*

## Indicator Light Accessory

### Flasher relay feature

To give the normal flashing frequency to those bike adopting the LED light bulbs modification, Totally plug & play, it's really easy to install. Can be adopted by many different model of bike (please check the from below for the detail) Installing Instruction as below.



#### i Flash Relay

Type Item number

no sound version  \* K B 0 0 6 0 4 0 \*



#### LED Flash Relay

Type Item number

no sound version  \* K B 0 0 6 0 0 0 \*



#### LED Flash Relay

Type Item number

with blink sound  \* K B 0 0 6 0 2 0 \*

#### FOR 3-PIN

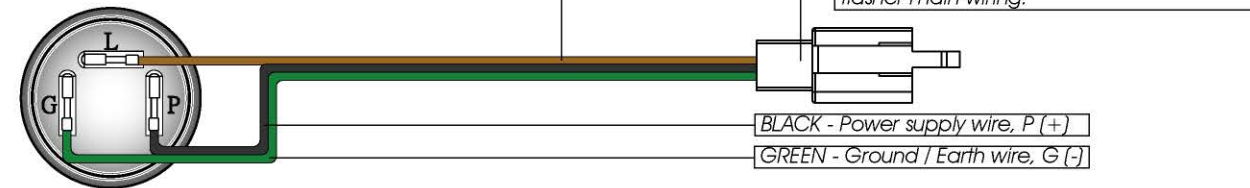

#### FOR 2-PIN

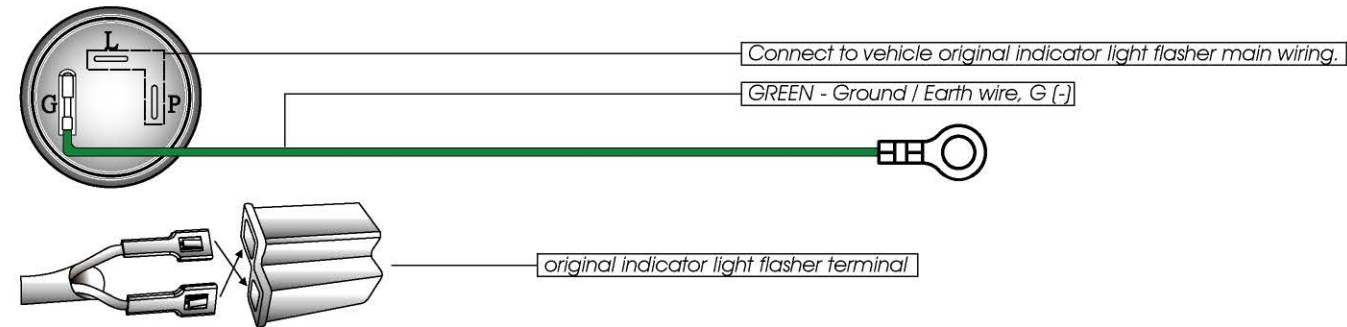

During installation, please follow the instructions below:

1. Before installation, locate and disconnect the vehicle original signal light interrupter terminal.
2. After disconnection, reconnect the terminals in opposite position.
3. After exchanging terminals position, connect the original indicator light flasher wiring to the LED flasher's L and P pins.

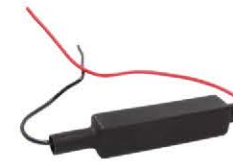

### Resistor for LED Turn Signal

Item number

 20w8.5Ω

 10w3Ω



### Directional light transfer gasket

Item number

 \* B 0 6 2 3 K 0 2 \*













• For Honda MSX

### WINKER ADAPTER WIRE

Type

- A. KAWASAKI
- B. HONDA
- C. DUCATI
- D. HARLEY DAVIDSON
- E. TRIUMPH
- F. MV AUGUSTA
- G. YAMAHA MT-09
- H. YAMAHA MT-07
- I. SUZUKI
- J. BMW
- BMW (x2)
- K. YAMAHA
- YAMAHA (x2)

Item number

-  \* B 0 0 2 1 0 0 0 \*
-  \* B 0 0 2 1 0 0 2 \*
-  \* B 0 0 2 1 0 6 0 \*
-  \* B 0 0 2 1 0 7 0 \*
-  \* B 0 0 2 1 0 8 0 \*
-  \* B 0 0 2 1 0 9 0 \*
-  \* B 0 0 2 1 1 0 0 \*
-  \* B 0 0 1 9 0 2 0 \*
-  \* B 0 0 1 9 0 3 7 \*
-  \* B 0 0 1 9 0 3 1 \*
-  \* B 0 0 1 9 0 5 0 \*
-  \* B 0 0 1 9 0 5 1 \*

### LICENSE PLATE LIGHT ADAPTER WIRE

Type

- 1. YAMAHA
- 1. YAMAHA

Item number

-  \* B 0 0 1 9 0 4 0 \*
-  \* B 0 0 2 1 0 5 0 \*

