



Thank you for purchasing our product. Before installing/operating the product, read the instructions carefully and retain them for future reference.

**⚠ Attention!**

- For installation, follow the steps described. Any damage caused by wrong installation shall be imputed to the users.
- Do not disassemble or change any parts. Opening and disassembling this unit will void any warranty.
- Maintenance and repairs should be executed by our professionals only.

**NOTE**

⚠ Some procedures must be followed to avoid damages to the product.

⚠ **WARNING!** Certain procedure must be followed to avoid damages to yourself, to the vehicle or to others.

**1 ACCESSORIES**

**1** High flow oil pump X1

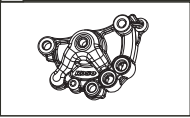

**2** Outer rotor X1



**3** Inner rotor X1



**4** Axle X1

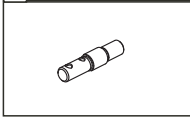

**5** Fixed pin X1



**2 OIL PUMP ASSEMBLY**

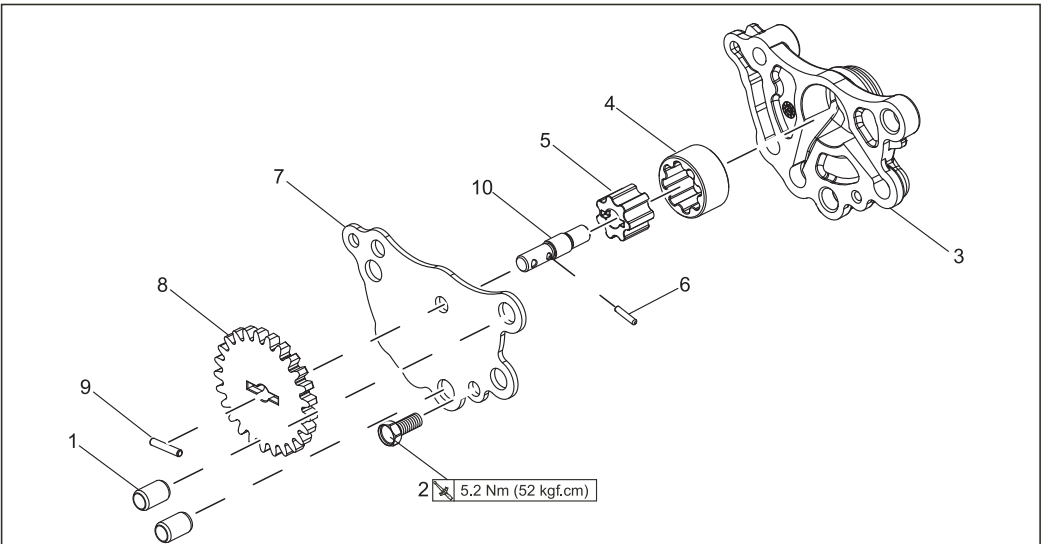

**PART DESCRIPTIONS**

- |                              |                              |                                     |
|------------------------------|------------------------------|-------------------------------------|
| 1. Lock pin                  | 2. Screw                     | 3. High flow oil pump (Accessory 1) |
| 4. Outer rotor (Accessory 2) | 5. Inner rotor (Accessory 3) | 6. Fixed pin (Accessory 5)          |
| 7. Gasket                    | 8. Gear                      | 9. Stock Fixed pin                  |
| 10. Axle (Accessory 4)       |                              |                                     |

**NOTE** Assemble in the order shown above. Make sure to disassemble the parts in reverse order (highest number to lowest number).

### 3 OIL PUMP FLOW CURVE CHART

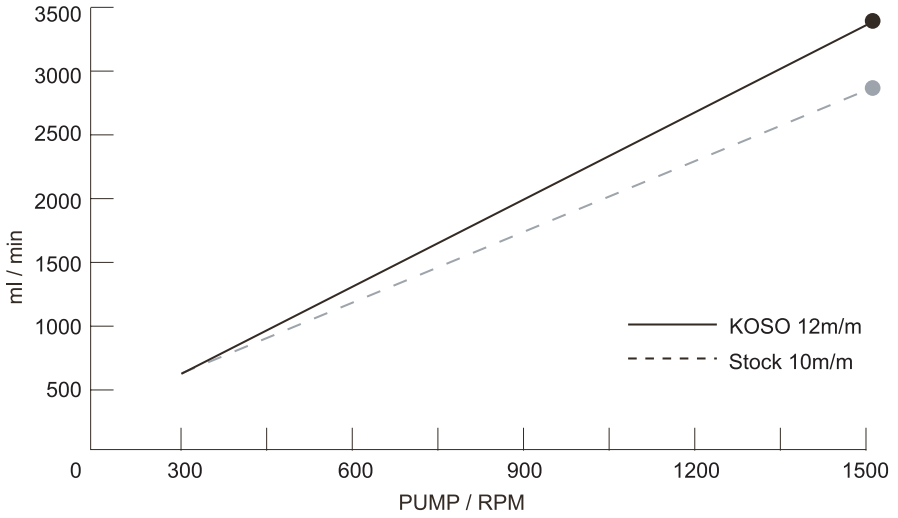

**NOTE** Oil flow is 20% more than with the stock one.