



● Thank you for purchasing our product. Before installing/operating the product, read the instructions thoroughly and retain them for future reference.

⚠ Attention!

- For installation, follow the steps described. Any damage caused by wrong installation shall be imputed to the users.
- To avoid a short circuit from occurring do not pull or modify the wires during installation.
- Do not disassemble or change any parts. Opening and disassembling this unit will void any warranty.
- Maintenance and repairs should be executed by our professionals only.

© Symbol description:

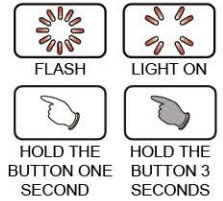

NOTE

⚠ Some procedures must be followed to avoid damages to the instrument.

⚠ **WARNING!** Certain procedure must be followed to avoid damages to yourself, to the vehicle or others.

1 Accessories

1 Power Test Box X1

2 Zip tie X1

3 Velcro X1

2 Installation instructions

Can be installed in two different ways, find the one suitable for your vehicle and follow the instructions. Follow the steps below during installation.

Installation method A

① Use the proper tool to drill a hole on the correct position of the body case.

NOTE When drilling the hole, be aware the diameter of the hole cannot be smaller than 3mm. If the diameter is smaller than 3mm, then the zip tie may not be able to pass.

② Power Test Box (Accessory 1)
③ Zip tie (Accessory 2)

Installation method B

① Vehicle case position
② Velcro - Female (Accessory 3)
③ Velcro - Male (Accessory 3)
④ Power Test Box (Accessory 1)

NOTE Clean the surface (including grease, water or dust) where you want to apply the Velcro before applying. Also use your thumb to press the Velcro after applying it on the surface to ensure the Velcro is in full contact with the surface.

NOTE Total harness length is 1000mm (1m), so be aware when drilling the hole to prevent a shortage of the harness.

3 Instruction of function

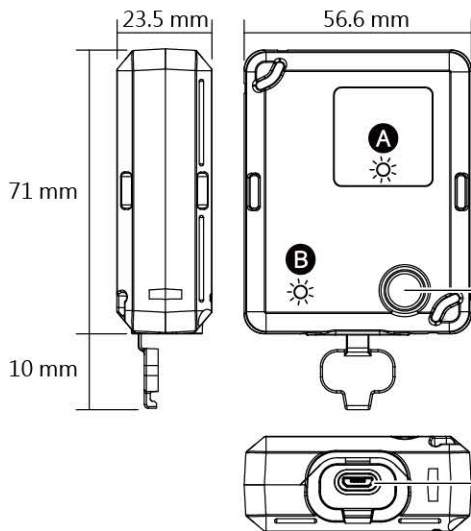

Light instruction:

- **A** GPS Light (Red)
Flash=Signal · NO Flash=NO Signal
- **B** Status light
 - On (Pink → White) → yellow (medium power) → Red (low power)
 - (Staggered flash) → Bluetooth pairing (blue)
- Power On Charging (blue)
- Power Off Charging (red → green)

On/Off
(Press the button
for 3 seconds.)

Micro USB Charging port

● USB charging voltage	DC 5 V
● Effective temperature range	-10 ~ 60 °C
● IP Level	IP54
● Size	71 X 56.6 X 23.5 mm
● Weight	About 75.5 g

⚠ When the USB Charger port is not in use, close the cover to avoid dust intrusion which can damage the port.

NOTE Design and specifications are subject to change without notice.

4 APP QR Code installation

This product needs to be used with the K Race App. Scan the QR Code below or search and download K Race from Apple App Store.

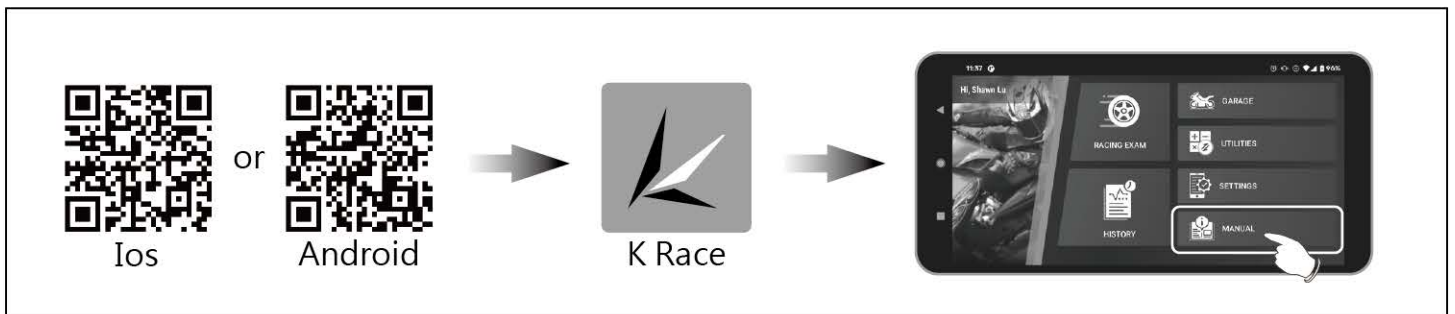

⚠ The App is designed for RACE PURPOSE only, please DO NOT use on-road.

5 Trouble shooting

The following situation does not indicate malfunction of the product. Check the following below before contacting us.

Trouble	Check item
No charging function or Indicator light not functioning.	<ul style="list-style-type: none"> ● There may be no power supply → Check the charging cable if it is properly connected → Check the charging light if it is lights up.
Indicator light not flashing	<ul style="list-style-type: none"> ● The Bluetooth Module might not be functioning properly. → Shut down the device for 5 seconds and restart again.

※If the problems still can't be solved, please contact us for assistance.