



# INSTRUCTION



● Thank you for purchasing **KOSO Fuel meter**, please read the instruction thoroughly before installing.

## ⚠ Notice

1. The LCD meter is applicable for DC 12V.
2. For installation, please follow the steps described in the manual. Any damage caused by wrong installation shall be imputed to the user.
3. Don't break or modify the wire terminal. To avoid short circuit, please don't pull the wire when installing.
4. Do not disassemble or change any parts excluding the manual description.
5. The interior examination or maintenance should be executed by our professionals.



### ◎ MARK MEANING:

**NOTE** You could get the installation details from the information behind the mark.

⚠ Some processes must be followed to avoid the affection caused by wrong installation.

**WARNING!** Some processes must be followed to avoid damages to yourself or the public.

**CAUTION!** Some processes must be followed to avoid the damage to the vehicle.

## 1-1 Accessory

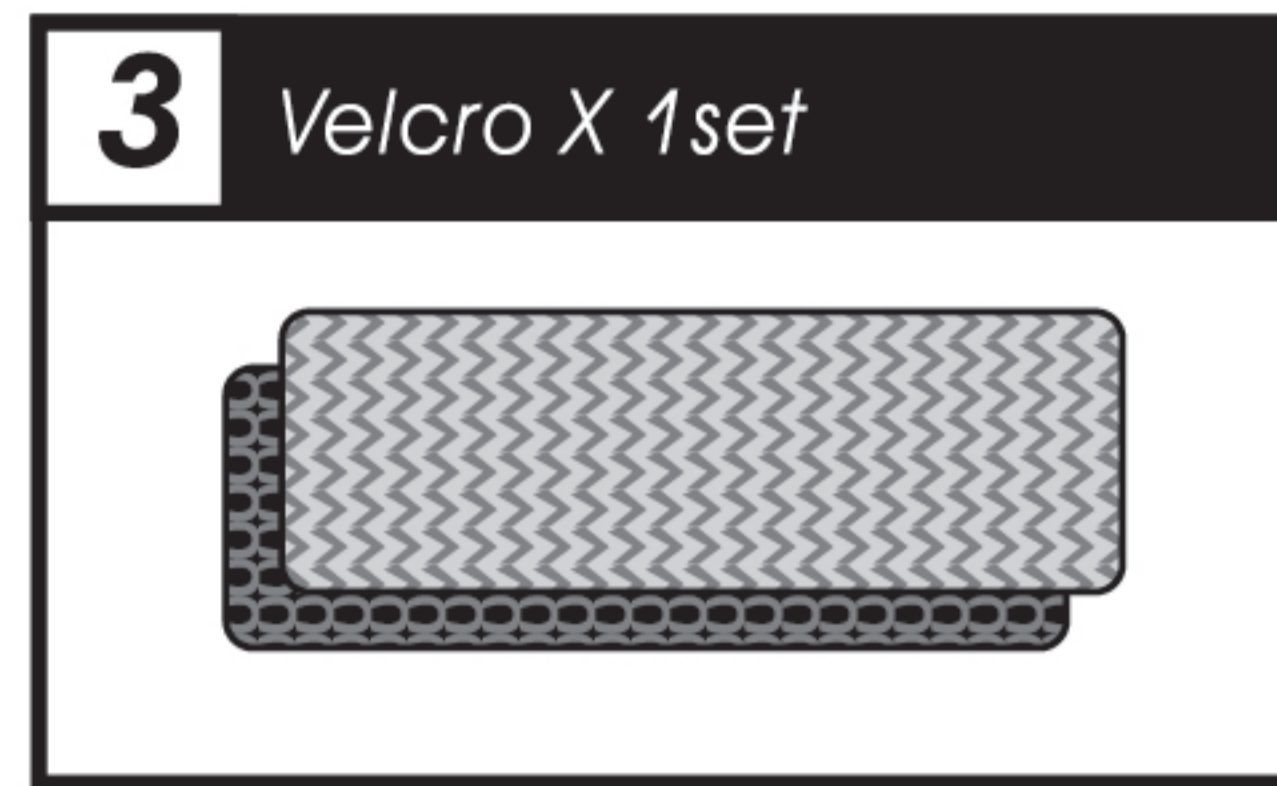
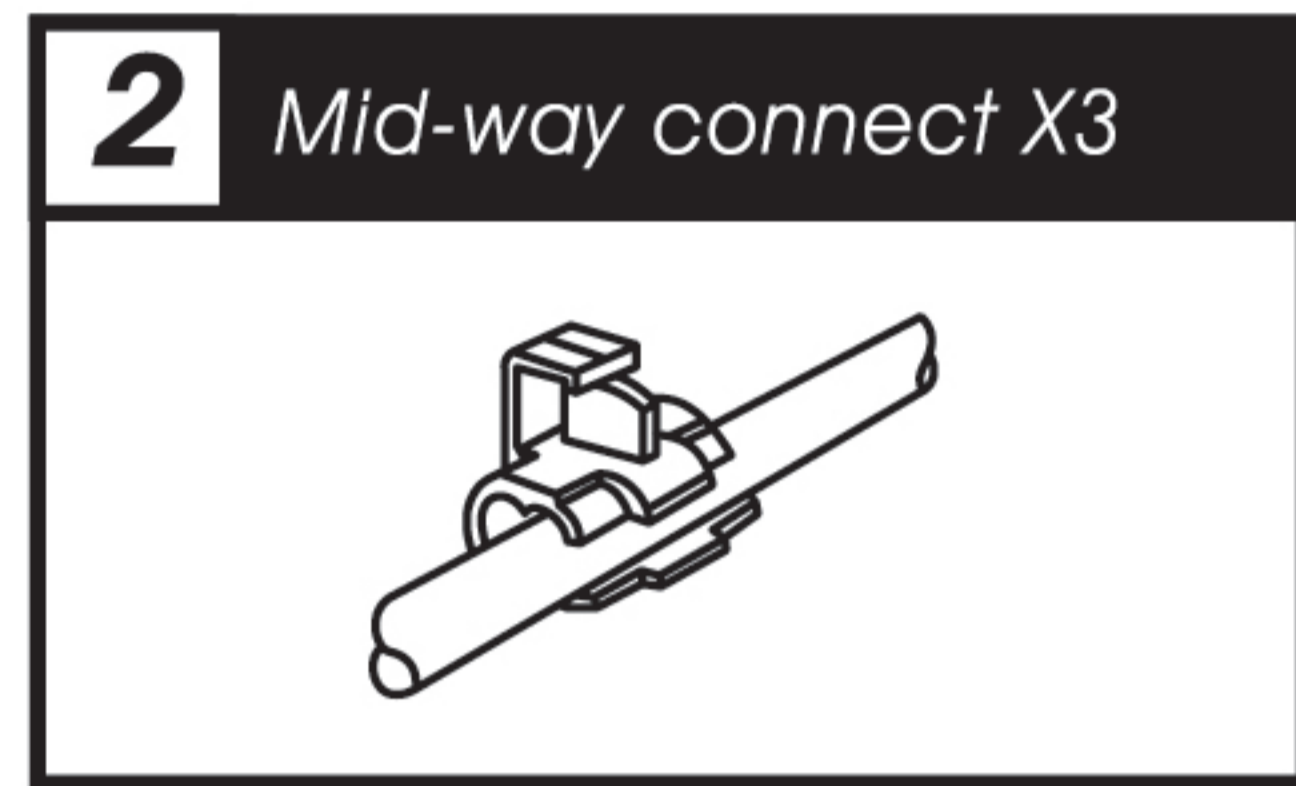
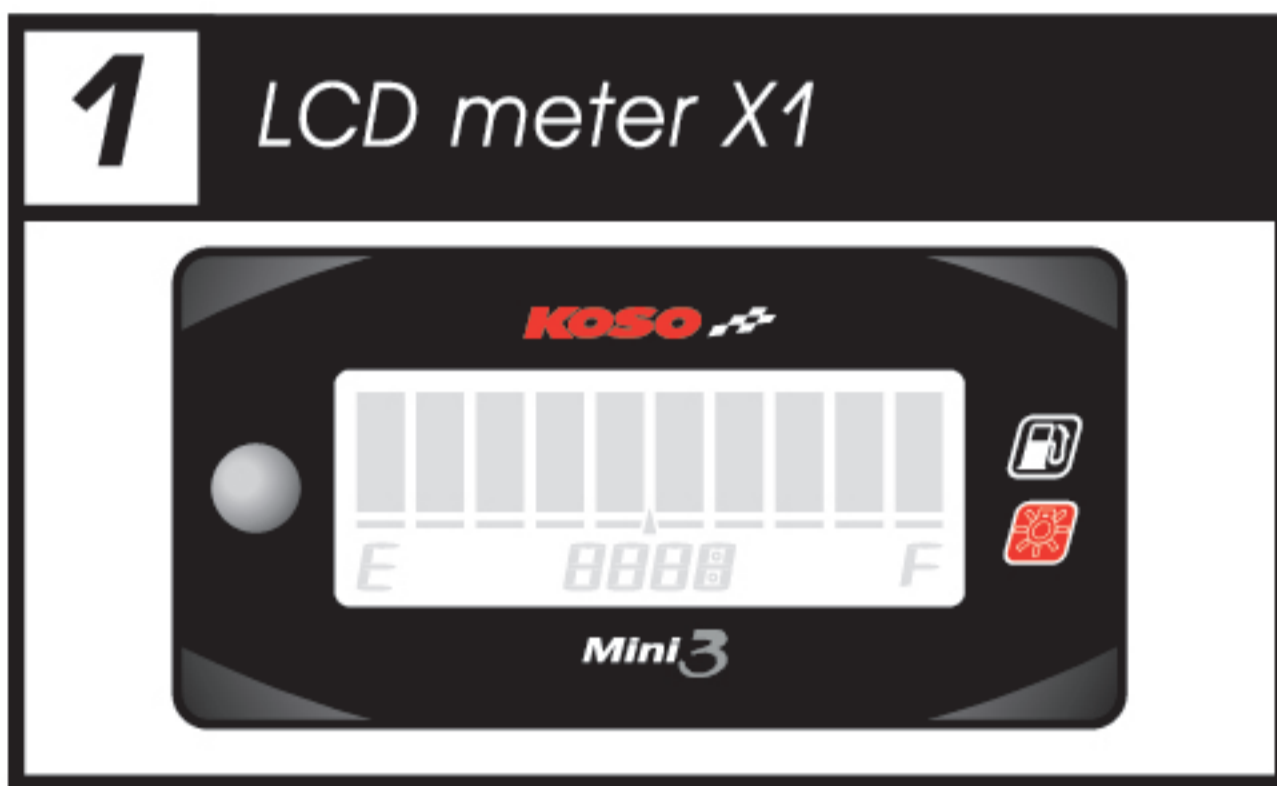

**NOTE** Please contact the local distributor if the items you open are not the same, with the above-listed one.

## 2 Wiring installation instructions

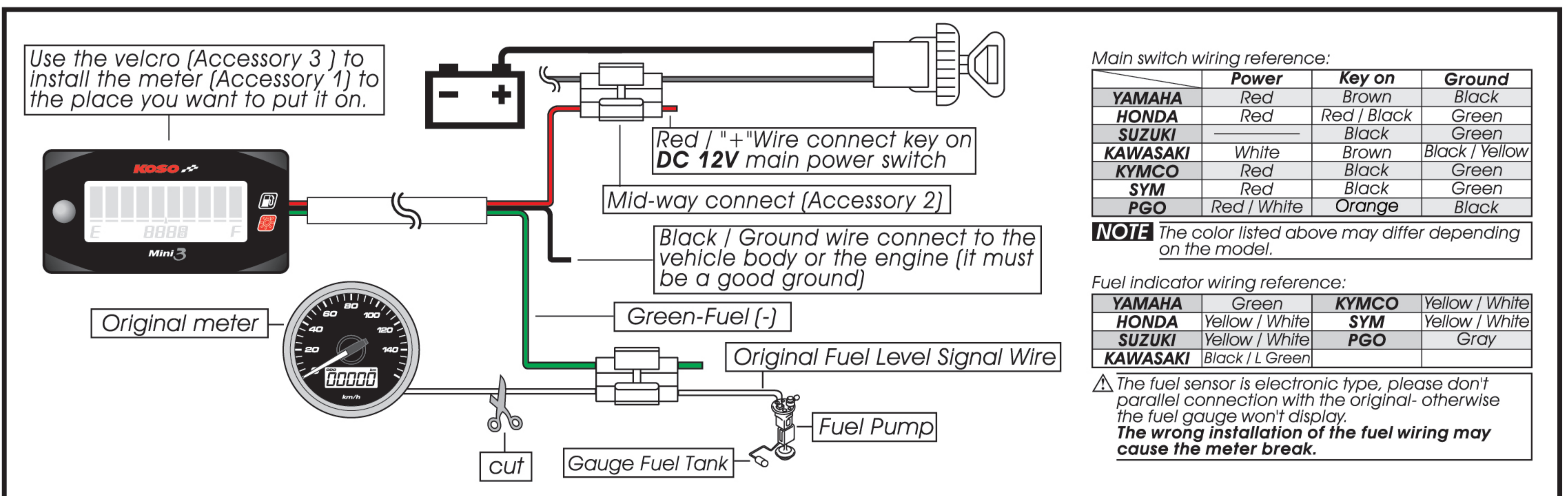

## 3-1 Basic function instruction

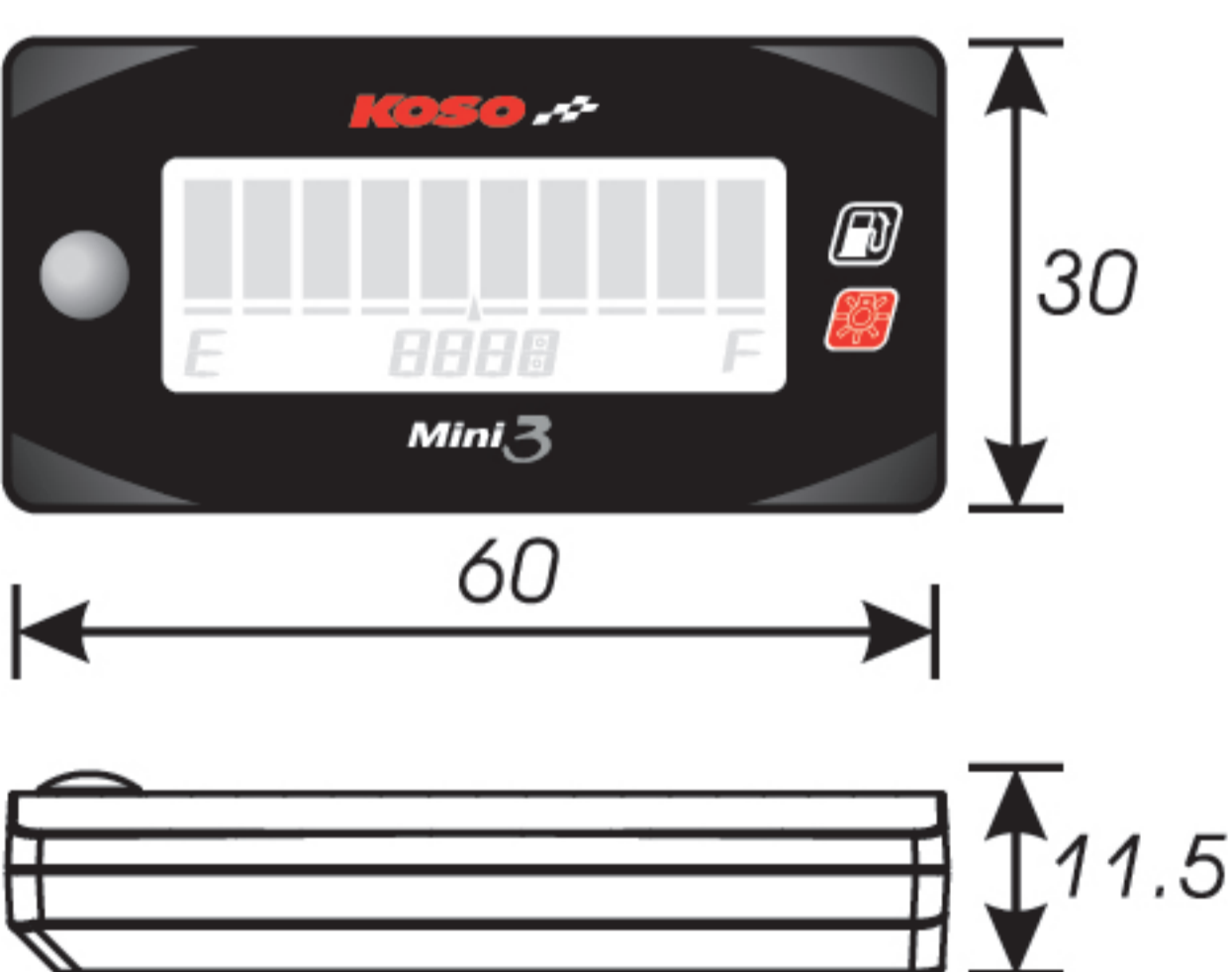

- Fuel level  
Display range: 10 levels  
Display unit: Each level represents 10%
- Digital fuel meter  
Display range: 0~100%  
Display unit: 1%
- Fuel gauge resistance setting  
Setting range: 100Ω, 180Ω, 250Ω, 270Ω, 510Ω, 700Ω, 1200Ω, user
- Fuel warning setting  
Setting range: 0~25%  
Setting unit: 1%
- Effective voltage  
**DC 12V**
- Effective temperature range  
-10~60°C
- Meter standard  
JIS D 0203 S2
- Meter size (W X L X H)  
W60 X L30 X H11.5 mm
- Meter weight  
Around 22g

**NOTE** Design and specifications are subject to change without notice!

## 3-2 The fuel meter setting instruction

### 3-2-1 The fuel gauge resistance setting



- In main screen, Hold pressing the **button** for **3 seconds** to enter the setting screen.



- **EX. The fuel gauge need to be set to 510Ω.**
- Press the **button** to change the setting.

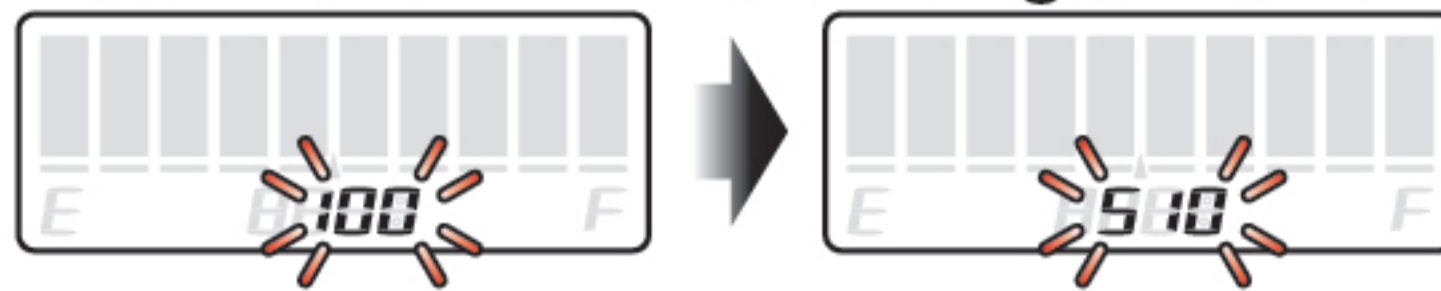

**NOTE** The fuel gauge resistance setting range: 100Ω, 180Ω, 250Ω, 270Ω, 510Ω, 700Ω, 1200Ω, USER.  
USER MODE means enter into fuel level learning setting (Please refer to 3-2-3)



- Hold pressing the **button** for **3 seconds** to enter the fuel warning setting screen.
- **EX. The setting is changed from 100Ω to 510Ω.**

### 3-2-2 The fuel warning setting



- **EX. We want to set the fuel warning at 20%.**
- Press the **button** to change the setting.

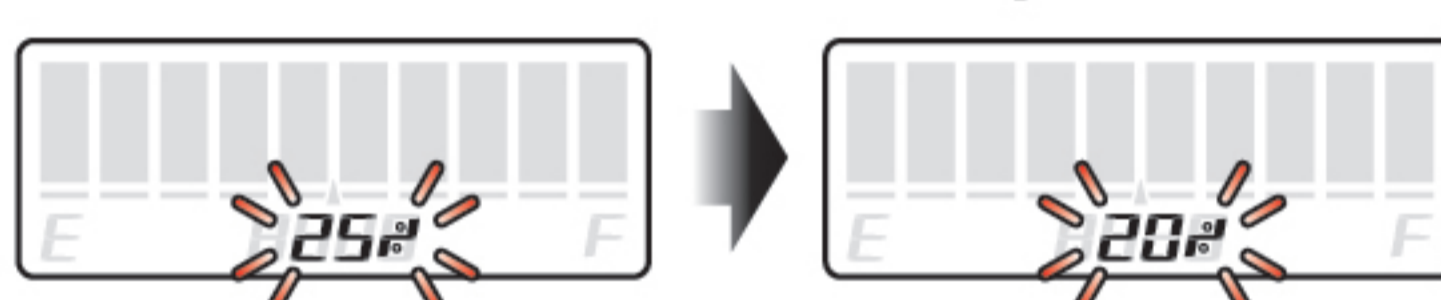

**NOTE** Setting range: 0%~25%  
Setting unit: 1%



- Hold pressing the **button** for **3 seconds** to go back to the main screen.
- **EX. The fuel warning is changed from 25% to 20%.**



- Main screen.

### 3-2-3 Fuel learning setting



- In setting screen, press the **button** to choose **USER**.
- Hold pressing the **button** for **3 seconds** to enter the empty fuel setting screen.

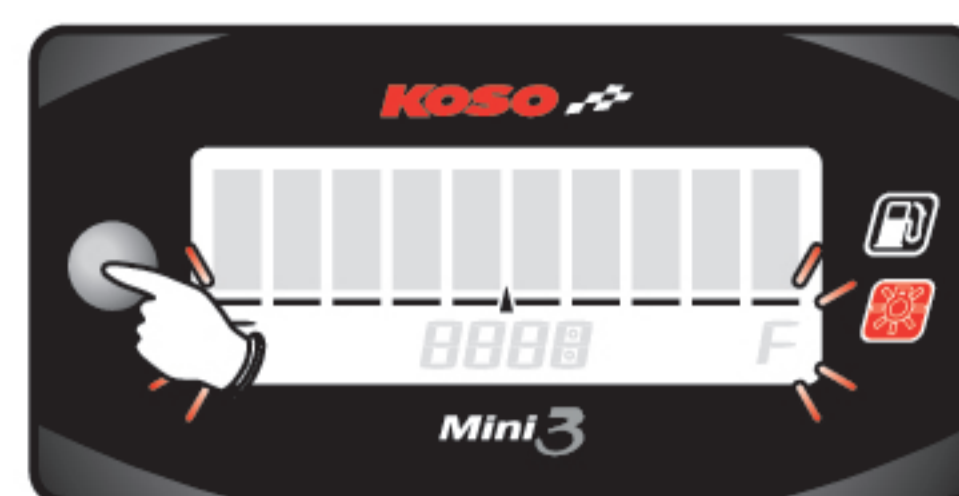

- **EX. Learning empty fuel.**
- Make sure the fuel amount is at the empty fuel position you want.
- Press the **button** once to confirm the setting.



※ If the LCD shows **DONE**, it means the setting is done.



※ When the LCD shows **BERR**, it means there is something wrong. Please check is the connection is correct or the fuel resistance value is over the setting range.

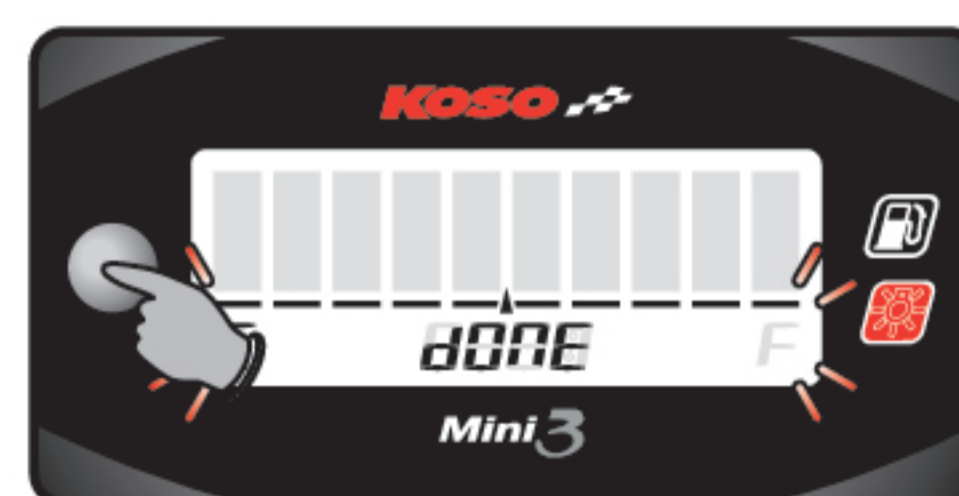

- Hold pressing the **button** for **3 seconds** to enter the full fuel setting screen.

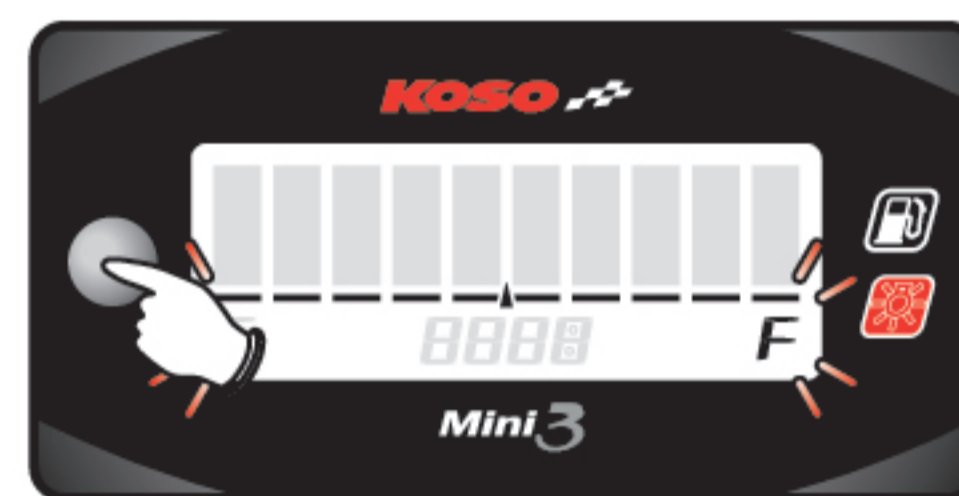

- **EX. Learning full fuel.**
- Make sure the fuel amount is at the full fuel position you want.
- Press the **button** once to confirm the setting.

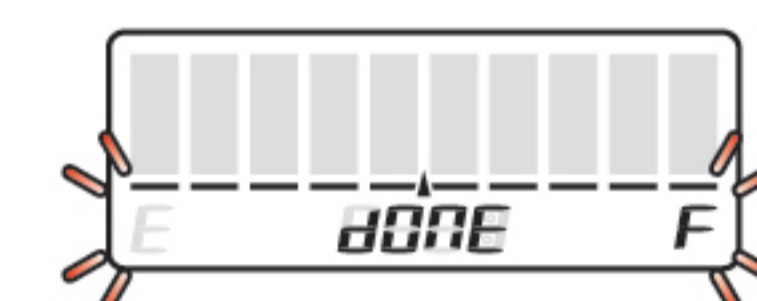

※ If the LCD shows **DONE**, it means the setting is done.



※ When the LCD shows **BERR**, it means there is something wrong. Please check is the connection is correct or the fuel resistance value is over the setting range.

## 4 Fuel gauge resistance reference

YAMAHA	JOG 50,100	100Ω
	RS 100	100Ω
	RSZ 100	100Ω
	SV MAX 125	100Ω
	Cygnus 125	100Ω
	New Cygnus 125	100Ω
	GTR 125	100Ω
	LC 135	100Ω
	NEW LC 135	100Ω
	LAGENDA 110	100Ω
	S-MAX 150	100Ω
	T-MAX 530	100Ω
	MIO 110	100Ω
	AEROX 50	100Ω
BWS 125	100Ω	
HONDA	MSX 125	270Ω
	WAVE 110	510Ω
	GN5 110	510Ω
	SH-150i	510Ω
	PCX 125	100Ω
	CBR 250	180Ω
GILERA	RUNNER 50	100Ω
PEUGEOT	SpeedFight 50	100Ω
APRILIA	SR 50	100Ω
SUZUKI	V125	100Ω

KYMCO	GOING 100	510Ω
	JR 100	510Ω
	SR G4 125	510Ω
	V-LINK GP 125	510Ω
	KTR 150	100Ω
	RACING 125,150	1200Ω
	QUANNON 150	1200Ω
	G5 125,150	1200Ω
	G6 150	100Ω
	VJR 50, 110	1200Ω
SYM	S-PRO 100	100Ω
	Wolf 125	100Ω
PGO	G-MAX 125	100Ω
	X-HOT 125,150	100Ω
	I'ME 125	100Ω
	J BUBU 115	700Ω
	AF 125,150	700Ω
AEON	G-MAX 150	700Ω
	Elite 250	100Ω
	CO-IN 125	100Ω
	MY 125,150	100Ω
	OZ 125,150	100Ω
Hartford	Mini 125	100Ω
	HD 150	100Ω

## 5 Trouble shooting

The following situation do not indicate malfunction of the meter. Please check the following before taking it in for repair.

Trouble	Check item
The meter doesn't work when the power is on.	<ul style="list-style-type: none"> <li>● The power doesn't supply to the meter. → Please make sure the wiring is connected. The wiring and fuse are not broken.</li> <li>→ The battery is broken or the battery is too old to supply enough power <b>DC 12V</b> to make the meter work.</li> </ul>
Fuel gauge does not appear or appear incorrectly.	<ul style="list-style-type: none"> <li>● Please check your fuel tank. → Is there any fuel inside?</li> <li>● Please check the wiring. → Do you connect the wiring correctly?</li> <li>● Please check the setting. → Please refer the the manual 3-2-1.</li> </ul>

※ If still can't solve the problems according to the steps above, please contact with distributors or us.